

# **CITY OF LAFAYETTE**

**3675 Mt. Diablo Boulevard, Suite 210  
(925) 284-1951  
www.ci.lafayette.ca.us**



## **NOTICE TO CONTRACTORS BID PROPOSAL CONTRACT AGREEMENT CONTRACT SPECIAL PROVISIONS**

**FOR**

## **2023 SURFACE SEAL PROJECT**

**Project No. 014-9739**

**Bid Opening Date**

**Thursday, June 29th , 2023, 2:00 p.m.**

TABLE OF CONTENTS

	<u>Page No.</u>
<b>NOTICE TO CONTRACTORS</b> .....	N-1
<b>BID PROPOSAL</b> .....	P-1
BID SCHEDULE .....	P-2
NONCOLLUSION DECLARATION .....	P-5
PROPOSAL GUARANTEE “BID BOND” WITH NOTORIZED SHEETS.....	P-6
PROPOSAL SIGNATURE SHEET.....	P-7
PUBLIC WORKS CONTRACTOR REGISTRATION CERTIFICATION .....	P-8
<b>CONTRACT AGREEMENT FOR CONSTRUCTION</b> .....	C-1
PAYMENT BOND .....	C-5
PERFORMANCE BOND .....	C-6
<b>SPECIAL PROVISIONS</b>	
SECTION SP 1 – GENERAL.....	S1
SECTION SP 2 – NOT USED	
SECTION SP 3 – NOT USED	
SECTION SP 4 – PLANS AND SPECIFICATIONS (GENERAL).....	S1
SECTION SP 5 – CONTROL OF WORK AND MATERIALS.....	S2
SECTION SP 6 – LEGAL RELATIONS AND RESPONSIBILITIES .....	S5
SECTION SP 7 – EXISTING UTILITIES .....	S6
SECTION SP 8 – PROGRESS OF WORK .....	S7
SECTION SP 9 – NOT USED	
SECTION SP 10 – NOT USED	
SECTION SP 11 – NOT USED	
SECTION SP 12 – NOT USED	
SECTION SP 13 – MOBILIZATION.....	S10
SECTION SP 14 – TRAFFIC CONTROL .....	S11
SECTION SP 15 – DUST CONTROL .....	S15
SECTION SP 16 – CLEARING & GRUBBING, TREE AND VEGETATION TRIMMING .....	S15
SECTION SP 17 – EXISTING HIGHWAY FACILITIES .....	S16
SECTION SP 18 – NOT USED	
SECTION SP 19 – ASPHALT PAVEMENT .....	S17

SECTION SP 20 – CRACK SEALING .....S18  
SECTION SP 21 – SEAL COAT .....S20  
SECTION SP 22 – NOT USED  
SECTION SP 23 – NOT USED  
SECTION SP 24 – NOT USED  
SECTION SP 25 – NOT USED  
SECTION SP 26 – TEMPORARY PAVEMENT DELINEATION ..... S22  
SECTION SP 27 – PAVEMENT STRIPING, MARKERS AND DELINEATION ..... S23

- APPENDIX A: WASTE MANAGEMENT PLAN INSTRUCTIONS**
- APPENDIX B: STANDARD PLANS**
- APPENDIX C: STAGING AREA LOCATION AND LIMITS**
- APPENDIX D: QUANTITY SUMMARIES**
- APPENDIX E: PLAN SHEETS AND DETAILS**
- APPENDIX E: RESIDENT NOTIFICATION LETTERS**
- APPENDIX F: PROJECT NOTIFICATION SIGNS**

## NOTICE TO CONTRACTORS

Sealed proposals will be accepted at the office of the City Clerk, 3675 Mt. Diablo Boulevard, Suite 210, Lafayette, California until 2:00 P.M., Thursday, June 29th, 2023, at which time they will be publicly opened and read, for: Construction **2023 Surface Seal Project, Project No. 014-9739**, including, but not limited to: mobilization; traffic control and construction signage; clearing and grubbing including tree and vegetation trimming; traffic striping, marking and marker removal; asphalt concrete pavement repairs, crack seal; slurry seal; traffic stripes, markers, and markings; and all other miscellaneous work as shown on the Plans and as described in the Specifications to provide a complete project.

The Engineer's cost estimate is \$303,000.

An electronic link to the contract documents, including the Plans and Specifications, may be obtained free of charge through the City of Lafayette Engineering Services Division by contacting the Engineering Assistant at [tkain@lovelafayette.org](mailto:tkain@lovelafayette.org) or (925)284-1951.

This project shall be constructed in accordance with the March 2013 edition of the City of Lafayette Standard Specifications, available free of charge on the City's website or for purchase through the City of Lafayette Engineering Services Division. The cost of the Standard Specifications is \$20 per set; the cost of mailing is an additional \$8.

Bids shall be submitted in a sealed envelope titled "**Proposal: 2023 Surface Seal Project, Project No. 014-9739**".

The Contractor shall possess a Class "A" license at the time this contract is awarded.

Bidder's attention is directed to requirements in Sections 2 and 3 of the Standard Specifications General Provisions. All bids shall be accompanied by a cashier's or certified check, or a bidder's bond executed by a corporate surety insurer. The bidder's guarantee shall be in the amount equal to at least ten (10) percent of the total bid and shall be made payable to the City of Lafayette. The successful bidder shall furnish a payment bond and a performance bond.

The City reserves the right to waive any informalities or to reject any or all bids.

The City Council has ascertained the General Prevailing Rates of Wages applicable to this work, and these rates are on file in the office of the City of Lafayette Engineering Services Division.

Time of completion allowed for this project will be forty **(40) working days**. Bidder's attention is directed to the schedule stated in Section SP-8 of the Special Provisions.

Questions regarding the project plans or specifications may be directed to Tim Clark, City Engineering Office, (925) 299-3245.

The plan holders list, as well as the City Standard Specifications, the Project Special Provisions and the General Prevailing Rates of Wages applicable to this work may be downloaded free of charge from the City of Lafayette web site at <http://www.ci.lafayette.ca.us> (click on *Public Works and Construction* under the Quick Links sidebar on the homepage, then *City Construction Projects; 2023 Surface Seal Project* is accessible under *Projects Bidding*). Or you may contact the Engineering Assistant at (925) 284-1951.

CITY OF LAFAYETTE

Date: 6/2/2023

By: \_\_\_\_\_  
Tim Clark, Assistant Engineer

**CITY OF LAFAYETTE  
CALIFORNIA**

**BID PROPOSAL**

**2023 SURFACE SEAL PROJECT**

**PROJECT No. 014-9739**

TO THE CITY COUNCIL OF THE CITY OF LAFAYETTE:

In compliance with the annexed notice inviting sealed proposals, the undersigned bidder hereby proposes and agrees to perform the work therein described and to furnish all labor, materials and equipment necessary therefor, in accordance with the Plans and Specifications therefor, and further agrees to enter into a contract therefor, at the following prices:

<u>ITEM NO.</u>	<u>ITEM DESCRIPTION</u>	<u>ESTIMATED QUANTITY</u>	<u>UNIT</u>	<u>UNIT PRICE</u>	<u>TOTAL</u>
-----------------	-------------------------	---------------------------	-------------	-------------------	--------------

(SEE ATTACHED BID SCHEDULE)

- NOTES:
- All unit prices shall be considered the prices for providing a complete, in-place facility.
  - In the event of a discrepancy between the unit price and item total on the Bid Schedule, the unit price shall be used.

o o o

Bidder acknowledges the receipt of the following addenda to the drawings and specifications.

<u>Addendum No.</u>	<u>Date</u>	<u>Addendum No.</u>	<u>Date</u>
_____	_____	_____	_____
_____	_____	_____	_____

o o o

**CITY OF LAFAYETTE**  
**2023 SURFACE SEAL PROJECT - NO. 014-9739**  
**BID SCHEDULE**

**BASE BID**

ITEM NO.	ITEM DESCRIPTION	ESTIMATED QUANTITY	UNIT	UNIT PRICE	TOTAL
1	Mobilization (SP-13)	1	LS		
2	Traffic Control (SP-14)	1	LS		
3	Clearing and Grubbing, Tree and Vegetation Trimming (SP-16)	1	LS		
4	Pavement Repair (3-Inch) (SP-19)	3,223	SF		
5	Pavement Repair (6-Inch) (SP-19)	3,449	SF		
6	Crack Seal (SP-20)	1	LS		
7	Slurry Seal, Type II (SP-21)	29,841	SY		
8	Remove Existing Pavement Markers and Thermoplastic Stripes and Legends (SP-17)	1	LS		
9	Temporary Pavement Delineation (SP-26)	1	LS		
10	Thermoplastic Legends and Markings (SP-27)	641	SF		
11	12" White or Yellow Thermoplastic Stripe (SP-27)	947	LF		
12	Yield Line (SP-27)	22	LF		
13	Detail 6- Dashed Centerline with Reflectors (SP-27)	2,429	LF		
14	Detail 21-Centerline without Reflectors (SP-27)	500	LF		
15	Detail 22- Centerline with Reflectors (SP-27)	1,561	LF		
16	Detail 27B-Fog Line (SP-27)	6,153	LF		
17	Detail 29 - Double Yellow Median Island (SP-27)	95	LF		
18	Detail 37 - Lane Drop at Exit Ramps (SP-27)	375	LF		
19	Detail 38- Chanelizing Stripe with Reflectors (SP-27)	814	LF		
20	Detail 38A-Chanelizing Stripe without Reflectors (SP-27)	347	LF		
21	Detail 38B- Chanelizing Stripe with Reflectors on Both Sides (SP-27)	321	LF		
22	Detail 39 - Bike Lane Solid Line (SP-27)	1,320	LF		
23	Detail 39A - Bike Lane Dashed Line (SP-27)	336	LF		
24	Detail 40- Chanelizing Stripe with Reflectors on Both Sides (SP-27)	53	LF		
25	Curb Paint (SP-27)	431	LF		
26	Install Two-Way Reflective Pavement Markers (Blue) (SP-27)	9	EA		
	<b>TOTAL BASE BID</b>				

**Attention Bidders:**

Bidders shall complete both the "Base Bid" and "Alternate Bid" in order to submit a responsive bid. The contract will be awarded on the basis of the lowest responsible bid for the Base Bid. The City will determine and reserves the right and discretion after the Bid Opening whether to include Alternate Bid item(s) per bid prices submitted by the contractor selected. The contractor shall honor said bid prices. The contractor will be advised of the addition at the pre-construction meeting.

Bidder agrees that in case of default in executing and returning the required contract and bonds within ten (10) calendar days after having received the contract, proceeds of the guarantee accompanying his bid will become the property of the City of Lafayette.

o o o

In conformance with Subsection 2-13 "Listing of Proposed Subcontractors" of the Standard Specifications, the name and location of the place of business of each subcontractor is as follows:

	<u>NAME</u>	<u>DIR NUMBER</u>	<u>ADDRESS</u>	<u>WORK TO BE PERFORMED</u>
1.	_____	_____	_____	_____
2.	_____	_____	_____	_____
3.	_____	_____	_____	_____
4.	_____	_____	_____	_____
5.	_____	_____	_____	_____

o o o

Bidder certifies that he is licensed in accordance with an act providing for the registration of Contractors as follows:

License No. \_\_\_\_\_ Class \_\_\_\_\_

o o o

Bidder certifies that he has not, nor have any of his or its agents, officers, representatives, or employees, been guilty of collusion with any officer or representative of the City of Lafayette or with any other party or parties in the submission of this Proposal; nor has said bidder received any preferential treatment by any officer or employee of the City of Lafayette in the matter of making or submitting this proposal. The undersigned declares under penalty of perjury that the foregoing is true and correct.

o o o

Bidder certifies that there will be no discrimination in employment with regard to race, color, religion, sex, sexual orientation, or national origin; that all Federal, State, and local directives and executive orders regarding nondiscrimination in employment will be complied with and that the principle of equal opportunity in employment will be demonstrated positively and aggressively.

All bidders that have not had a contract with the City of Lafayette during the past three (3) years shall list below previous jobs that they have successfully completed and shall also show the amount of the contract therefor.

Name and Address of Agency or Individual for Whom Work was Done	Phone Number	Date Completed	Contract Price
1.			
2.			
3.			
4.			
5.			
6.			



**NONCOLLUSION DECLARATION**

The undersigned declares:

I am the \_\_\_\_\_ of \_\_\_\_\_, the party making the foregoing bid.  
*Title Firm*

The bid is not made in the interest of, or on behalf of, any undisclosed person, partnership, company, association, organization, or corporation. The bid is genuine and not collusive or sham. The bidder has not directly or indirectly induced or solicited any other bidder to put in a false or sham bid. The bidder has not directly or indirectly colluded, conspired, connived, or agreed with any bidder or anyone else to put in a sham bid, or to refrain from bidding. The bidder has not in any manner, directly or indirectly, sought by agreement, communication, or conference with anyone to fix the bid price of the bidder or any other bidder, or to fix any overhead, profit, or cost element of the bid price, or of that of any other bidder. All statements contained in the bid are true. The bidder has not, directly or indirectly, submitted his or her bid price or any breakdown thereof, or the contents thereof, or divulged information or data relative thereto, to any corporation, partnership, company association, organization, bid depository, or to any member or agent thereof to effectuate a collusive or sham bid, and has not paid, and will not pay, any person or entity for such purpose.

Any person executing this declaration on behalf of a bidder that is a corporation, partnership, joint venture, limited liability company, limited liability partnership, or any other entity, hereby represents that he or she has full power to execute, and does execute, this declaration on behalf of the bidder.

I declare under penalty of perjury under the laws of the State of California that the foregoing is true and correct and that this declaration is executed on \_\_\_\_\_, at

*Date*

\_\_\_\_\_, \_\_\_\_\_.

*City*

*State*

By: \_\_\_\_\_  
*Signature*

Name: \_\_\_\_\_  
*Printed or Typed*

Date: \_\_\_\_\_

Title: \_\_\_\_\_

**PROPOSAL GUARANTEE**

**BID BOND**

**2023 SURFACE SEAL PROJECT**

**PROJECT No. 014-9739**

KNOW ALL PERSONS BY THESE PRESENTS that \_\_\_\_\_, as BIDDER, and \_\_\_\_\_, as SURETY, are held and firmly bound unto City of Lafayette, as Owner, in the penal sum of \_\_\_\_\_ dollars (\$) which is ten percent of the total amount bid by BIDDER to Owner for the above stated project, for the payment of which sum, BIDDER and SURETY agree to be bound, jointly and severally, firmly by these presents.

THE CONDITIONS OF THIS OBLIGATION ARE SUCH that, whereas BIDDER is about to submit a bid to Owner for the above stated project, if said bid is rejected, or if said bid is accepted and a contract is awarded and entered into by BIDDER in the manner and time specified, then this obligation shall be null and void, otherwise it shall remain in full force and effect in favor of Owner.

IN WITNESS WHEREOF the parties hereto have set their names, titles, hands, and seals this \_\_\_\_ day of \_\_\_\_\_, 2023.

BIDDER \_\_\_\_\_  
\_\_\_\_\_  
\_\_\_\_\_

SURETY \_\_\_\_\_  
\_\_\_\_\_  
\_\_\_\_\_

Subscribed and sworn to this \_\_\_\_ day of \_\_\_\_\_, 2023.

NOTARY PUBLIC \_\_\_\_\_

### PROPOSAL SIGNATURE SHEET

The completed proposal submitted herewith includes all sheets numbered "P-1 through P-8" at the bottom. The following required attachments have been executed and are included:

- a. Bid Proposal (with Addenda acknowledgement)
- b. Bid Schedule
- c. Noncollusion Declaration
- d. Proposal Guarantee "Bid Bond" with Notarized Signatures
- e. Proposal Signature Sheet
- f. Public Works Contractor Registration Certification

Legal Name of Firm: \_\_\_\_\_

Business Address: \_\_\_\_\_

Telephone Number: ( ) \_\_\_\_\_

Type of Organization: ( ) Individual ( ) Partnership ( ) Corporation

Joint Venture Proposal?: ( ) Yes ( ) No

Authorized Signature: \_\_\_\_\_

Name: \_\_\_\_\_

Position: \_\_\_\_\_

Date of Execution: \_\_\_\_\_

For a partnership, name all co-partners below,  
For a corporation, name president, secretary, treasurer and manager.

**NAME**

**TITLE**

_____	_____
_____	_____
_____	_____
_____	_____

Corporate Seal:

**PUBLIC WORKS CONTRACTOR REGISTRATION CERTIFICATION**

Pursuant to Labor Code sections 1725.5 and 1771.1, all contractors and subcontractors that wish to bid on, be listed in a bid proposal, or enter into a contract to perform public work must be registered with the Department of Industrial Relations. See <http://www.dir.ca.gov/PublicWorks/PublicWorks.html> for additional information.

No bid will be accepted nor any contract entered into without proof of the contractor's and subcontractors' current registration with the Department of Industrial Relations to perform public work.

Contractor hereby certifies that it is aware of the registration requirements set forth in Labor Code sections 1725.5 and 1771.1 and is currently registered as a contractor with the Department of Industrial Relations.

Name of Contractor: \_\_\_\_\_

DIR Registration Number: \_\_\_\_\_

Contractor further acknowledges:

1. Contractor shall maintain a current DIR registration for the duration of the project.
2. Contractor shall include the requirements of Labor Code sections 1725.5 and 1771.1 in its contract with subcontractors and ensure that all subcontractors are registered at the time of bid opening and maintain registration status for the duration of the project.
3. Failure to submit this form or comply with any of the above requirements may result in a finding that the bid is non-responsive.

Signature: \_\_\_\_\_

Name and Title: \_\_\_\_\_

Dated: \_\_\_\_\_

**CITY OF LAFAYETTE**  
**CONTRACT AGREEMENT**  
**FOR**  
**CONSTRUCTION**

THIS AGREEMENT is made and entered into as of \_\_\_\_\_, 2023, by and between the CITY OF LAFAYETTE ("City") and \_\_\_\_\_ ("Contractor").

RECITALS

- A. City desires to retain the services of Contractor to provide services for Construction of **2023 Surface Seal, Project No. 014-9739**, including, but not limited to: mobilization; traffic control and construction signage; clearing and grubbing including tree and vegetation trimming; traffic striping, marking and marker removal; asphalt concrete pavement repairs, crack seal; slurry seal; traffic stripes, markers, and markings; and all other miscellaneous work as shown on the Plans and as described in the Specifications to provide a complete project.
- B. Contractor has represented to City that it has the expertise, experience and qualifications to perform the services described in Paragraph A, above, and those services which are more fully described below.

NOW, THEREFORE, in consideration of the foregoing and the covenants and agreements set forth below, City and Contractor agree as follow:

- 1. Contract Documents. The contract documents for the aforesaid project shall consist of the Notice to Contractors, Bid Proposal, General Provisions, Technical Provisions, Special Provisions including appendices, Design Drawings, and all referenced specifications, details, standard drawings, and their appendices; together with this Contract Agreement and all required bonds, insurance certificates, permits, notices and affidavits; and also including any and all addenda or supplemental agreements clarifying, amending, or extending the work contemplated as may be required to insure its completion in an acceptable manner. All of the provisions of said contract documents are made a part hereof as though fully set forth herein.
- 2. Services. For and in consideration of the payments and agreements to be made and performed by City, Contractor agrees to furnish all materials and perform all work required for the above-stated project, and to fulfill all other obligations as set forth in the aforesaid contract documents. Contractor agrees to receive and accept the prices set forth in the Proposal as full compensation for furnishing all materials, performing all work, and fulfilling all obligations hereunder. Said compensation shall cover all expenses, losses, damages, and consequences arising out of the nature of the work during its progress or prior to its acceptance including those for well and faithfully completing the work and the whole thereof in the manner and time specified in the aforesaid contract documents; also including those arising from actions of the elements, unforeseen difficulties or obstructions encountered in the prosecution of the work, suspension or discontinuance of the work, and all other unknowns or risks of any description connected with the work.
- 3. Employment by City. City hereby promises and agrees to employ, and does hereby employ, Contractor to provide the materials, do the work, and fulfill the obligations according to the terms and conditions herein contained and referred to, for the prices aforesaid, and hereby contracts to pay the same at the time, in the manner, and upon the conditions set forth in the contract documents.

4. Worker's Compensation. Contractor acknowledges the provisions of the State Labor Code requiring every employer to be insured against liability for worker's compensation, or to undertake self-insurance in accordance with the provisions of that Code, and certifies compliance with such provisions. Limits shall be not less than those specified in the insurance requirements contained in the General Provisions of the Standard Specifications, and as modified in these Special Provisions.
5. Insurance. With respect to performance of work under this contract, Contractor shall maintain and shall require all of its subcontractors to maintain insurance as required in the General Provisions of the Standard Specifications, and as modified in these Special Provisions.
6. Indemnity. Contractor shall comply with the indemnification requirements contained in the General Provisions of the Standard Specifications and the Special Provisions.
7. Assignment. This contract is not assignable nor the performance of either party's duties delegable without the prior written consent of the other party. Any attempted or purported assignment or delegation of any of the rights or obligations of either party without the prior written consent of the other shall be void and of no force and effect.
8. Non-discrimination. Contractor shall not discriminate in the hiring of employees or the employment of subcontractors on any basis prohibited by law.
9. Independent Contractor. Contractor is and shall at all times remain as to City, a wholly independent contractor. Neither City nor any of its agents shall have control of the conduct of Contractor or any of the Contractor's employees, except as herein set forth. Contractor shall not at any time or in any manner represent that it or any of its agents or employees are in any manner agents or employees of City.
10. Contractor and Subcontractor Registration. Pursuant to Labor Code sections 1725.5 and 1771.1, all contractors and subcontractors that wish to bid on, be listed in a bid proposal, or enter into a contract to perform public works must be registered with the Department of Industrial Relations. No bid will be accepted nor any contract entered into without proof of the contractor's and subcontractors' current registration with the Department of Industrial Relations to perform public work. Contractor is directed to review, fill out and execute the Public Works Contractor Registration Certification contained in the Bid Proposal prior to contract execution.
11. Labor Compliance. This Project is subject to compliance monitoring and enforcement by the Department of Industrial Relations. It shall be the Contractor's sole responsibility to evaluate and pay the cost of complying with all labor compliance requirements under this Contract and applicable law.
12. Notices. All notices and communications shall be sent to the parties at the following addresses:

CITY:                   City Engineer  
                              City of Lafayette  
                              3675 Mount Diablo Boulevard, Suite 210  
                              Lafayette, California 94549

CONTRACTOR: \_\_\_\_\_  
\_\_\_\_\_  
\_\_\_\_\_  
\_\_\_\_\_

- 13. Authorized Signature. Contractor affirms that the signatures, titles, and seals set forth hereinafter in execution of this contract agreement represent all individuals, firm members, partners, joint ventures, and/or corporate officers having a principal interest herein.
- 14. Entire Agreement; Modification. This contract supersedes any and all other agreements either oral or written, between the parties and contains all of the covenants and agreements between the parties pertaining to the work of improvements described in Paragraph A of the Recitals herein above. Each party to this contract acknowledges that no representations, inducements, promises, or agreements, orally or otherwise, have been made by any party, or anyone acting on behalf of any party, which are not embodied herein, and that any other agreement, statements or promise not contained in this contract shall not be valid or binding. Any modification of this contract will be effective only if signed by the party to be charged.
- 15. Claims Procedure. In the event of a dispute between the parties regarding a) a time extension demand, b) payment arising for work performed by or on behalf of the contractor which is not otherwise expressly provided for, or c) an amount the payment of which is disputed by the City, the procedure in Section 10 of the City of Lafayette Standard Specifications shall be used.

IN WITNESS WHEREOF the parties hereto for themselves, their heirs, executors, administrators, successors, and assigns do hereby agree to the full performance of the covenants herein contained and have caused this Contract Agreement to be executed in duplicate by setting hereunto their names, titles, hands, and seals this \_\_\_\_ day of \_\_\_\_\_ 2023.

Contractor: \_\_\_\_\_  
<Type Business Name Here>

Name: \_\_\_\_\_

Title: \_\_\_\_\_

Contractor's License No. \_\_\_\_\_

Federal Tax Identification No. \_\_\_\_\_

Subscribed and sworn to this \_\_\_\_ day of \_\_\_\_\_ 2023.

Notary Public \_\_\_\_\_

Agency: \_\_\_\_\_

City Manager of the City of Lafayette

Attested: \_\_\_\_\_  
City Clerk of the City of Lafayette

Date: \_\_\_\_\_



**PAYMENT BOND**

**(TO BE EXECUTED WITHIN TEN [10] CALENDAR DAYS OF CONTRACT AWARD)**

WHEREAS, the City of Lafayette (Owner) has awarded to \_\_\_\_\_, as Contractor, a contract for the work described as follows: Construction of **2023 Surface Seal, Project No. 014-9739**, including, but not limited to: mobilization; traffic control and construction signage; clearing and grubbing including tree and vegetation trimming; traffic striping, marking and marker removal; asphalt concrete pavement repairs, crack seal; slurry seal; traffic stripes, markers, and markings; and all other miscellaneous work as shown on the Plans and as described in the Specifications to provide a complete project.

AND WHEREAS, said Contractor is required to furnish a bond in connection with said contract, to secure the payment of claims of laborers, mechanics, materials persons, and other persons as provided by law;

NOW, THEREFORE, we, the undersigned Contractor and surety, are held firmly bound unto the Owner in the sum of \_\_\_\_\_ Dollars (\$ \_\_\_\_\_), for which payment well and truly to be made we bind ourselves, our heirs, executors and administrators, successors and assigns, jointly and severally, firmly by these presents.

THE CONDITION OF THIS OBLIGATION IS SUCH:

That if said Contractor, its heirs, executors, administrators, successors, or assigns, or subcontractors, shall fail to pay any of the persons named in Civil Code Section 3282, or amounts due under the Unemployment Insurance Code with respect to work or labor performed by any such claimant, or any amounts required to be deducted, withheld, and paid over to the Employment Development Department from the wages of employees of the Contractor and its subcontractors pursuant to Section 13020 of the Unemployment Insurance Code, with respect to such work and labor, that the surety or sureties herein will pay for the same in any amount not exceeding the sum specified in this bond, otherwise the above obligation shall be void. In case suit is brought upon this bond, the said surety will pay a reasonable attorney's fee to the Owner in an amount to be fixed by the court.

This bond shall insure to the benefit of any of the persons named in Civil Code Section 3181 as to give a right of action to such persons or their assigns in any suit brought upon this bond.

IN WITNESS WHEREOF, we have hereunto set our hands and seals on this \_\_\_\_ day of \_\_\_\_\_, 2023.

CONTRACTOR: _____	SURETY _____
Print Name: _____	NAME _____
Title: _____	ADDRESS _____
	TELEPHONE _____

**PERFORMANCE BOND**

**(TO BE EXECUTED WITHIN TEN [10] CALENDAR DAYS OF CONTRACT AWARD)**

KNOW ALL PERSONS BY THESE PRESENTS:

THAT WHEREAS, the City of Lafayette (Owner) has awarded to \_\_\_\_\_, as Contractor, a contract for the work described as follows: Construction of **2023 Surface Seal, Project No. 014-9739**, including, but not limited to: mobilization; traffic control and construction signage; clearing and grubbing including tree and vegetation trimming; traffic striping, marking and marker removal; asphalt concrete pavement repairs, crack seal; slurry seal; traffic stripes, markers, and markings; and all other miscellaneous work as shown on the Plans and as described in the Specifications to provide a complete project.

AS WHEREAS, the Contractor is required to furnish a bond in connection with said contract guaranteeing the faithful performance thereof;

NOW, THEREFORE, we, the undersigned Contractor and surety, are held firmly bound unto the Owner in the sum of \_\_\_\_\_ Dollars (\$ \_\_\_\_\_), to be paid to the Owner, its successors and assigns, for which payment well and truly to be made we bind ourselves, our heirs, executors and administrators, successors and assigns, jointly and severally, firmly by these presents.

THE CONDITION OF THIS OBLIGATION IS SUCH:

That if said Contractor, its heirs, executors, administrators, successors, or assigns, shall in all things stand to and abide by and well and truly keep and perform the covenants, conditions, and agreements in the foregoing contract and any alteration thereof made as therein provided on its or their part to be kept and performed at the time and in the manner therein specified and in all respects according to their true intent and meaning, and shall indemnify and save harmless the Owner, its officers, and agents, as therein stipulated, then this obligation shall become and be null and void; otherwise it shall be and remain in full force and effect. In case suit is brought upon this bond, the said surety will pay a reasonable attorney's fee to the Owner in an amount to be fixed by the court. Surety, for value received, hereby stipulates and agrees that no amendment, change, extension of time, alteration, or addition to said contract, and of any feature or item or items of performance required therein or thereunder, shall in any manner affect its obligations on or under this bond; and said surety does hereby waive notice of any such amendment, change, extension of time, alteration, or addition to said contract, and of any feature or item or items of performance required therein or thereunder, shall in any manner affect its obligations on or under this bond; and said surety does hereby waive notice of any such amendment, change extension of time, alteration, or addition to said contract, and of any feature or item or items of performance required therein or thereunder.

IN WITNESS WHEREOF, we have hereunto set our hands and seals on this \_\_\_\_ day of \_\_\_\_\_, 2023.

CONTRACTOR: _____	SURETY _____
Print Name: _____	NAME _____
Title: _____	ADDRESS _____
	TELEPHONE _____

**SPECIAL PROVISIONS SECTION SP-1**

**GENERAL**  
(NO BID ITEM)

**SP 1-01 REFERENCE SPECIFICATIONS**

The work to be done under this contract, except as modified or supplemented herein, shall conform to the following:

- The City of Lafayette General Provisions of the Standard Specifications dated March 2013, herein referred to as the “General Provisions of the Standard Specifications.”
- The City of Lafayette Technical Provisions of the Standard Specifications dated March 2013, herein referred to as the “Technical Provisions of the Standard Specifications.”

Where specifically referred to, the work shall also conform to the following:

- The State of California Department of Transportation (Caltrans) Standard Specifications, 2022, herein referred to as the “State Specifications” or “State Standard Specifications.”
- The State of California Department of Transportation (Caltrans) Standard Plans, 2022 with revisions, herein referred to as the “State Standard Plans.”
- The Contra Costa County Public Works Department Standard Plans, most current edition, herein referred to as the “County Standard Plans.”

These Special Provisions are additions, modifications, or clarifications to the referenced Standard Specifications and generally supersede the referenced or applicable sections of said Standard Specifications. Refer to Section 5-4, “Precedence of Contract Documents”, of the General Provisions of the Standard Specifications for the order of precedence of Contract Documents. Where ambiguity or conflict exist in the interpretation of precedence, the provision resulting in the highest quality or most expensive grade of construction or product shall govern.

**SPECIAL PROVISIONS SECTION SP-2 (NOT USED)**  
**SPECIAL PROVISIONS SECTION SP-3 (NOT USED)**

**SPECIAL PROVISIONS SECTION SP-4**  
**PLANS AND SPECIFICATIONS (GENERAL)**  
(NO BID ITEM)

The provisions of Section 4, “Plans and Specifications (General),” of the General Provisions of the Standard Specifications shall apply in their entirety and as supplemented herein.

**SP4-01 SCOPE OF WORK**

The work to be performed under this contract includes, but not limited to: mobilization; traffic control and construction signage; clearing and grubbing including tree and vegetation trimming; traffic striping, marking and marker removal; asphalt concrete pavement repairs, crack seal; slurry seal; traffic stripes, markers, markings and signs; and all other miscellaneous work as shown on the Plans and as described in the Specifications to provide a complete project.

**SP4-02 AS-BUILT PLANS**

The City may retain a portion of the final retention until such time that the Contractor provides a complete set of As-Built Plans.

**SP4-03 PAYMENT**

No separate payment will be made for preparing and submitting "As-Built Drawings." Full compensation for preparing and submitting "As-Built Drawings" shall be considered as included in the prices paid for various contract items of work, and no additional compensation shall be allowed therefor.

**SPECIAL PROVISIONS SECTION SP-5**  
**CONTROL OF WORK AND MATERIALS**  
**(NO BID ITEM)**

The provisions of Section 5, "Control of Work and Materials," of the General Provisions of the Standard Specifications shall apply in their entirety and as supplemented herein.

**SP5-01 MATERIAL SAMPLING AND TESTING**

Compaction tests and/or material sampling and testing may be performed by the City's representatives on asphalt concrete, micro-surfacing materials, base rock and other work and materials which in the opinion of the Engineer require sampling or testing. Test locations shall be determined by the Engineer. The Contractor shall coordinate and cooperate with the Engineer and testing personnel and no claims of delays or inconvenience due to testing and/or sampling shall be allowed.

Testing is not a duty of the City and is solely at the discretion of the Engineer. Testing or non-testing by the City does not release the Contractor from his/her responsibility to perform all work in conformance with the Plans, Standard Specifications, and these Special Provisions.

If a test shows that the work in question fails to meet the project specifications, retests shall be taken after the Contractor takes corrective measures. Retests shall be performed until a passing test is obtained. All costs that the City incurs for retesting shall be deducted from the payment due the Contractor.

The Engineer shall be given at least twenty-four (24) hours advance notice for any testing requested by the Contractor.

### **SP5-02 SUBMITTALS**

**The Contractor shall provide all submittals required by the Standard Specifications and these Special Provisions at the preconstruction meeting and prior to commencing any work.**

Any work shown on the Plans to be installed per manufacturer's specifications or directions shall require a submittal. All materials specified by manufacturer name, code, model number, etc. and their approved equals shall require a Submittal.

All submittals shall be provided electronically for review. Mark each copy to identify the applicable products, models, options, and any other data. Submit the product source, specifications, gradations, certifications, bulletins and literature in sufficient detail to demonstrate that the product is in compliance with the Contract.

At minimum, the Contractor shall provide the following submittals to the Engineer. Submittals shall be made in advance of the materials planned incorporation into the work, and shall allow the Engineer a minimum of five (5) working days to review the submittal and respond to the Contractor. No material shall be used in the work until written acceptance of the submittal has been made by the Engineer. The Contractor shall submit sufficient information, specifications, and product data to demonstrate compliance with the requirements of the Contract, including these Special Provisions, for:

- Equipment calibration documentation for micro-surfacing equipment
- Slurry seal mix designs and certification of compliance
- Slurry Seal aggregate
- Slurry Seal asphalt emulsion
- Asphalt concrete mix design
- Crack sealant material
- Traffic paint and glass beads
- Thermoplastic striping material
- Curb painting paint material
- Pavement markers
- Water pollution control plan

- Waste management plan
- Traffic control plan and certification of qualified personnel
- Project schedule

**SP5-03 ORDER OF WORK**

Unless otherwise directed by the Engineer, the following major items of work shall be performed in the following order.

- 1) Submit waste management plan prior to commencing any demolition work
- 2) Notify Underground Service Alert (USA) to have utilities marked
- 3) Install construction area signs and project information signs
- 4) Install water pollution control measures
- 5) Clearing, grubbing, tree and vegetation trimming
- 6) Construct asphalt pavement repairs
- 7) Remove existing pavement markers, markings, and striping
- 8) Perform crack sealing
- 9) Install slurry on roadways and pathways to be sealed
- 10) Place temporary roadway delineation
- 11) Place permanent striping, markers and legends
- 12) Complete all other construction work and punch list items, including clean-up
- 13) Remove construction area signs and project information signs
- 14) Submit completed waste assessment summary report form

The Contractor's attention is directed to Section SP-8-02, "Progress Schedule," of these Special Provisions.

Any deviation from these requirements and provisions shall be sufficient cause for the Engineer to suspend the work in accordance with the provisions of Section 8-3 of the General Provisions. The contractor will not be permitted to resume the work until Contractor has satisfactorily remedied said deviation in accordance with the provisions of the contract.

**SP5-05 SUPERVISION**

Section 5-8 "Superintendence" of the General Provisions is superseded by the following:

Unless otherwise explicitly directed and authorized by the Engineer, at all times during the progress of the work the Contractor shall have a project representative present at the construction site who shall have complete authority to represent and to act for the Contractor. **The project representative may not be a subcontractor or an employee of the subcontractor.**

Before initial work is begun on the Contract, the Contractor shall file with the Engineer, address and telephone numbers where the project representative can be reached during all hours, including nights and weekends, when the work is not in progress. The Contractor's project representative shall: Supervise the work crews and subcontractors; coordinate all construction activities and operations including but not limited to traffic control; progress payment, change orders, work by others (including utility companies) and public notifications. Lack of supervision shall be cause to suspend the work as provided for in Section 8-3 of the General Provisions.

When supervision is not provided as required, the Engineer has the discretion to allow work to proceed in the interest of progress of work. In that case the City may assess the Contractor for the lack of such supervision. The assessment shall be based on the current City of Lafayette hourly billing rate for engineering staff of \$165 per hour, plus a twenty (20) percent administrative markup multiplied the number of hours such superintendence has not been provided. The assessment shall be deducted from any amounts due to the Contractor.

**SP5-06 PAYMENT**

No separate payment will be made for conforming to the provisions of this section. Full compensation for conforming to all the provisions of this section shall be considered as included in the prices paid for various contract items of work and no additional compensation will be allowed therefor.

**SPECIAL PROVISIONS SECTION SP-6**  
**LEGAL RELATIONS AND RESPONSIBILITIES**  
(NO BID ITEM)

The provisions of Section 6, "Legal Relations and Responsibilities," of the General Provisions of the Standard Specifications shall apply in their entirety and as supplemented herein, and in other related sections of these Special Provisions.

**SP6-01 PUBLIC NOTIFICATIONS**

Notification requirements in Section 6-10, 6-12.3, and 6-13 of the Standard Specifications General Provisions shall apply. Except as modified herein.

At least (2) two weeks prior to the start of construction, the Contractor shall provide schedule information to the City as well as the contractors contact information for public inquiries. The

schedule shall state the phase of work (Pavement Repair, Crack Seal, and Micro-surfacing) as well as the dates for this work. This information will be included in a public notice similar to the ones shown in Appendix E. Contractor shall not distribute door hangers. The City of Lafayette will mail notices to residents in Lafayette.

Contractor's attention is also directed to requirements specified in other sections of these Special Provisions regarding notification updates when work schedule changes.

**SP6-02 COORDINATION WITH WASTE/RECYCLING OPERATIONS**

The Contractor shall not impair or impede waste hauler and recycling operations scheduled to be conducted within the project area. It is the Contractor's responsibility to determine which waste haulers and recycling operators are scheduled to operate within the project area and to develop a project schedule that will not impair or impede the waste haulers or recycling operations. Contractor acknowledges that he is aware that various haulers and operators operate on different days on different streets within the project area.

Strictly for the Contractor's convenience and not as a requirement of the Contract, the Engineer may provide a schedule of waste and recycling pick-up days at the pre-construction meeting. The Contractor shall bear the responsibility to confirm this schedule with the waste and recycling companies prior to commencing his operations.

**SP6-03 INSURANCE AND INDEMNITY**

Contractor's attention is directed to Section 6-33 and 6-35 of the General Provisions of the Standard Specifications. The insurance protection and indemnification requirements therein shall extend to the City of Lafayette, including their officers, elected officials, agents, and employees. The required insurance policies shall name the City of Lafayette as additional insureds.

**SP6-04 PERMITS AND LICENSES**

The Contractor shall procure all permits and licenses, pay all charges and fees, and give all notices necessary and incidental to the due and lawful prosecution of the work.

**SP6-05 PAYMENT**

No separate payment will be made for conforming to the provisions of this section. Full compensation for conforming to all the provisions of this section shall be considered as included in the prices paid for various contract items of work and no additional compensation will be allowed therefor.

**SPECIAL PROVISIONS SECTION SP-7  
EXISTING UTILITIES  
(NO BID ITEM)**



The provisions of Section 7, "Existing Utilities," of the General Provisions of the Standard Specifications shall apply in their entirety and as supplemented herein.

### **SP7-01 UTILITY CONTACTS**

At the time of writing of these Specifications, at least the following agencies are known to have facilities within the limits of the Project. Their phone numbers are provided for the Contractor's convenience. It is Contractor's responsibility to verify the contact information and perform the coordination as required by Contract.

A. Central Contra Costa Sanitary District	925.228.9500
B. East Bay Municipal Utility District	510.287.0834
	866.403.2683
C. AT&T	415.542.9000
D. Pacific Gas and Electric	
Emergency	800.743.5000
Gas	510.784.3211
Electric	510.784.3236
E. Consolidated Fire Protection District	925.930.5531
F. Morag-Orinda Fire District	925.258-4599
G. Comcast Cable	925.349.3300
H. Sprint	650.513.2545

### **SP7-02 PAYMENT**

No separate payment will be made for conforming to the provisions of this section. Full compensation for conforming to all the provisions of this section shall be considered as included in the prices paid for various contract items of work and no additional compensation will be allowed therefor.

## **SPECIAL PROVISIONS SECTION SP-8**

### **PROGRESS OF WORK**

(NO BID ITEM)

The provisions of Section 8, "Progress of Work," of the General Provisions of the Standard Specifications shall apply in their entirety and as supplemented herein.

#### **SP8-01 PRE-CONSTRUCTION MEETING**

The Contractor shall submit all required bonds, insurance, and signed contracts. The Notice to Proceed will be issued to the Contractor at the pre-construction meeting. Note: The prime contractor's full-time on-site superintendent or foreman for the project is required to attend the preconstruction meeting.

At the pre-construction meeting, representatives of the Owner, the Contractor, Subcontractors, and the Engineer will discuss in detail certain procedural aspects of the work, including, but not limited to:

- Administrative procedures for transmittals, approvals, change orders, and similar items;
- Review of the method of application for payment, progress payments, retention; and final payment;
- Review of the Contractor's construction schedule;
- Clarifications of any questions regarding the contract Plans and Special Provisions;
- Review of traffic control and noticing procedures;
- Review of Caltrans encroachment permit conditions;
- At the preconstruction meeting the Contractor shall provide a traffic control plan.
- Water pollution control program;
- Review of Submittals (i.e. materials, equipment, etc.)

#### **SP8-02 PROGRESS SCHEDULE**

The Contractor shall submit the construction progress schedule to the Engineer at the pre-construction meeting and updated schedules every week and as requested by the Engineer as the work progresses as stated in Section 8-2, "Progress Schedule," of the General Provisions of the Standard Specifications.

Attention is directed to Section SP5-04, "Order of Work," of these Special Provisions. Each schedule shall specifically note the timeframe and work to be performed by each subcontractor by construction bid item and location. Subcontractors shall receive all updated schedules so they can plan an appropriate work force to meet the prime Contractor's timeframe.

**SP8-03 WORKING HOURS**

Without prior written approval by the Engineer, and except for emergency work, work or activity of any kind shall be limited to the hours from 8:00 a.m. to 5:00 p.m. Monday through Friday. The Contractor's attention is directed to Section SP14-03, "Lane Closure Hours," and Section SP14-04, "Road Closure Hours" of these Special Provisions.

No work will be allowed on City holidays except in an emergency. The City holidays are as follows:

New Year's Day  
Martin Luther King, Jr.'s birthday  
Washington's Birthday  
Memorial Day  
Independence Day  
Labor Day  
Columbus Day  
Veteran's Day  
Thanksgiving Day  
Day after Thanksgiving  
Christmas Eve  
Christmas Day

**SP8-04 TIME OF COMPLETION AND LIQUIDATED DAMAGES**

Contractor's attention is directed to SP-3 regarding the timing of award of Contract and commencement of work. The Contractor shall complete the entire work in this contract within Forty (40) working days from the original start date including completion of all "Punch List" work. The Contractor's attention is directed to Section 8-10, "Liquidated Damages," of the General Provisions of the Standard Specifications.

Completion of contract work is defined as completion of all items listed in the Bid Schedule and any issued Contract Change Order for the project, regardless of substantial use or benefit of any work in progress or portion of the project. "Punch List" items are considered to be a part of work items on the Bid Schedule.

Contract working days shall continue to be counted for the purpose of determining time of completion and liquidated damages until the completion of contract work as defined above, including completion of "Punch List" work.

**SP8-05 PAYMENT**

No separate payment will be made for conforming to the provisions of this section. Full compensation for conforming to all the provisions of this section shall be considered as included

in the prices paid for various contract items of work and no additional compensation will be allowed therefor.

**SPECIAL PROVISIONS SECTION SP-9 (NOT USED)**  
**SPECIAL PROVISIONS SECTION SP-10 (NOT USED)**  
**SPECIAL PROVISIONS SECTION SP-11 (NOT USED)**  
**SPECIAL PROVISIONS SECTION SP-12 (NOT USED)**

**SPECIAL PROVISIONS SECTION SP-13**

**MOBILIZATION**  
(BID ITEM NO. 1)

The provisions of Section 1, "Mobilization," of the Technical Provisions of the Standard Specifications shall apply in their entirety except as modified or supplemented herein.

**SP13-01 STAGING AREA**

The Contractor may stage materials and equipment in existing legal parking spaces within the project limits when authorized by the Engineer. Staging areas shall be protected by barricades with flashers.

Within Lafayette, one City-owned off-street site is available for the staging of equipment and materials. This site is located on the south side of Mount Diablo Boulevard adjacent to the intersection of Mount Diablo Boulevard and El Nido Ranch Road.

All materials brought onto the staging sites shall be completely removed within 48 hours of completion of the work that requires staging on these sites. Failure to vacate within five calendar days of the substantial completion of work will result in rent of \$1,000 per calendar day being deducted from monies owed to the Contractor. The entire contract retention amount shall be withheld for the purpose of deducting rent until Contractor vacates the staging site and restores it to preexisting condition or better. As directed by the Engineer, the Contractor shall install temporary six-foot-tall chain link fence along the property lines as shown in the drawing in Appendix C of these specifications, or as delineated by the Engineer in the field. The Contractor shall be responsible for the protection of the sites and the removal of any materials placed on the sites while they are under his control. The sites may not be used until the Contractor is ready to actively execute work contained in the Contract. At no time shall any maintenance or refueling of equipment or vehicles be performed on said site.

It is the Contractor's responsibility to inspect the site to determine the suitability for his operations to execute this contract. The City makes no guarantee, expressed or implied, that this area is appropriate for the work involved. It is the Contractor's responsibility to secure a staging area for Contract Work, and any associated costs are considered to be included in the various Contract Prices paid, with no additional compensation allowed therefor.

Other than the site referenced above, any of the Contractor's proposed staging sites shall be approved by the Engineer, and the Contractor shall submit proof of an agreement for use of said staging area with private property owner(s) prior to mobilization. Upon approval, Contractor shall obtain a temporary land use permit from the City of Lafayette Planning Division for use of staging in Lafayette. The City does not guarantee the granting of said permit as part of this contract. Contractor shall bear all costs to secure said permit.

The staging areas shall be maintained throughout the duration of the project such that they are not construed as visual blight in the opinion of the Engineer. All adjoining streets, sidewalks and gutters shall be swept clean throughout the day to ensure the bike lane and sidewalk are free of construction debris at all times. Temporary ramps built to access the site shall be made of temporary compacted asphalt. Failure to keep the all the adjoining streets, sidewalks, and gutters swept will result in City forces cleaning the area at the Contractor's expense, at the labor rate of \$150 per hour per person.

### **SP13-02 MEASUREMENT AND PAYMENT**

The lump-sum Contract Price paid for "**Mobilization**" shall include full compensation for furnishing all labor, supervision, materials, tools, equipment and incidentals, and for all the work involved in mobilization of forces, equipment, and materials; and conformance to all general conditions and provisions of Contract Documents and as directed by the Engineer, and no additional compensation will be allowed therefor, unless separately and specifically provided elsewhere in the Contract.

## **SPECIAL PROVISIONS SECTION SP-14**

### **TRAFFIC CONTROL**

(BID ITEM NO. 2)

### **SP14-01 GENERAL**

Traffic control shall conform to the requirements of Section 6-12, "Traffic Control," of the General Provisions of the Standard Specifications. Nothing in these Special Provisions shall be construed as relieving the Contractor from his/her responsibilities as specified in said sections.

### **SP14-02 DRIVEWAY CLOSURES**

Driveways that are closed-to-access shall be coned off or barricaded with a minimum of 2 cones or barricades per driveway, or with highly visible ribbon tied across the entire width of the driveway.

### **SP14-03 LANE CLOSURE HOURS**

Emergency vehicles shall be provided with immediate access through the construction area at all times. If work is not in progress during allowed lane closure hours and a traffic lane is closed, the Engineer may order the lane opened to public traffic.

Lane closures for Slurry Sealing shall be as follows:

- Before August 15, 2023, lane closure hours shall be 8:30 a.m. to 4:30 p.m. Monday through Friday, excluding holidays, for all streets.
- After August 15, 2023, lane closure hours shall be 9:00 to 2:00 p.m. for **St. Mary's Road and Solana Road** Monday through Friday, excluding holidays. The remaining streets shall be 8:30 a.m. to 4:30 p.m.

Traffic control for Acalanes Road shall follow the approved plan in the Caltrans Encroachment Permit. If Caltrans will only permit work to occur on Saturday or Sunday work on Saint Mary's Road may also be permitted on the same day.

#### **SP14-04 FULL ROAD CLOSURE HOURS**

**Full road closures shall only be permitted during the slurry seal phases of work. Road closures shall only be permitted on Webb Lane, Mountain View Drive, Sibert Court, Tanglewood Drive, Las Huertas Road, Hillcrest Drive and Willow Drive.**

Road closures hours shall be as follows:

- Before August 15, 2023, road closure hours shall be 8:30 a.m. to 4:30 p.m. Monday through Friday, excluding holidays, for all streets.
- After August 15, 2023, road closure hours shall be 9:00 to 2:00 p.m. for **St. Mary's Road, Solana Road** Monday through Friday, excluding holidays. The remaining streets shall be 8:30 a.m. to 4:30 p.m.

Contractor shall stage and sequence work such that road closures and disruptions to mobility of the public are minimized. Even under road closure conditions, Contractor shall make best efforts to allow passage of vehicles through the work zone when doing so does not interfere with active, critical work. This includes but is not limited to accommodating residents with medical, health, or safety-related needs (doctor appointments, emergency access, and access requirements due to physical disabilities). No road shall be closed to traffic until immediately prior to the application of the slurry seal. If work requiring closure is not actively in progress during allowed closure hours, the Engineer may order the road opened to public traffic. The Contractor shall coordinate road closures with garbage and recycling collection to ensure continuation of service during the construction period.

All streets shall be rolled and opened to traffic within 2 hours of the completion of slurry sealing operations on the road.

The full width of the traveled way shall be open for use by public traffic at all other times. Emergency vehicles shall be provided immediate access through the construction area at all times. If work is not in progress during allowed closure hours, the Engineer may order the road opened to public traffic.

**A flagperson must remain at street access points to the road and lane closures at all times to prevent unauthorized access into the road or lane closure zone.**

#### **SP14-05 PUBLIC PARKING**

Section 6-12.4 of the General Provisions of the Standard Specifications shall apply, except that posting of restrictions shall be at least three (3) days in advance.

A minimum of one restriction notice shall be posted between driveways, and the spacing of postings shall not exceed 100 feet. Parking restriction times shall conform to the lane closure hours listed in these Special Provisions.

#### **SP14-06 FAILURE TO COMPLY**

Contractor's attention is directed to Standard Specifications General Provision Section 6-12.9 "Failure to Comply", which shall be augmented as follows.

If the Contractor fails to provide traffic control measures in conformance with the submitted traffic control plan, the Engineer may at his sole discretion issue a written warning to the Contractor. The warning shall indicate the location, date, and time of the failure to provide adequate traffic control. After the Second written warning, any violation of the traffic control provisions of the contract documents shall constitute grounds for the City to levy a penalty against the Contractor in the amount of \$500 per incident. Each hour of contract work activity occurring without traffic control as required by contract shall constitute a separate incident for the purpose of assessing the penalty. Contractor shall note that the above provisions are in addition to remedies and enforcement actions specified in Section 6-12.9 referenced above. This penalty shall be deducted from any money due to the Contractor under the Contract.

Contractor's suggestions for minor deviations from the requirements of this section concerning hours of work, which do not alter the Contract Price, may be considered by the Engineer if, in his opinion, public traffic will be better served and the work expedited. These deviations shall not be implemented by the Contractor until the Engineer has approved the deviations in writing.

#### **SP14-07 PROJECT INFORMATION SIGNS**

The Contractor shall provide and install Project Information signs at all entrances and exits from the limits of work with a minimum of two signs required per street. The signs shall be printed with black lettering on a yellow background and shall have text similar to the example signs found in [Appendix F](#) of these Special Provisions. The signs shall be a minimum of 3 feet wide by 3 feet tall and shall state the phase of work (Pavement Repair, Crack Seal, and slurry sealing) as well as the dates and times for this work.

The signs may be printed on paper mounted to plywood. The contractor shall mount the signs to a Type III barricade. The Contractor shall submit a proof set for all notification signs to the Engineer for review and approval prior to manufacturing the signs. The notification signs for the initial phase of work shall be in place on the project site a minimum of (5) working days in advance

of performing work. All subsequent phases of work shall have notification signs in place a minimum of two (2) working days in advance of the start of work. The dates shown on the signs shall only include the days where work will be performed and a range of dates shall only be permitted if the operation requires multiple days to complete.

If any phase of work identified in the written notice to residents or subsequent project information sign is not undertaken on the date(s) and time(s) identified, Contractor shall update the sign boards in accordance with these Special Provisions. Contractor shall install updated notification signs at least two days in advance of performing work on the street. The Contractor shall provide written notice of intended schedule changes and shall submit a proof set for all re-notification signs for review and approval prior to manufacturing the signs. Failure to provide written notice of intended schedule changes and sign proof set may require re-notification and the restart of the two day period.

The Contractor shall install and maintain all project notification signs in legible condition for the entire duration of Contract. At no time shall dates be written on the signs by hand. The contractor may use stickers to denote the dates of work. The stickers must be a minimum of 1" in height (72 pt font).

#### **SP14-08 CONSTRUCTION AREA SIGNS**

The Engineer shall approve all locations prior to the Contractor installing signs. Signs shall be in place on the project site at least two (2) days but not more than seven (7) days prior to the start of work on each street. Signs shall be removed within five (5) days of completing all work on each street. The Contractor shall notify the regional notification center for operators of subsurface installations (USA-Underground Service Alert: 811), at least four (4) working days, but not more than fourteen (14) calendar days, prior to commencing any excavation for construction area sign posts.

"Road Work Ahead" (Type W20-1) signs shall be placed on all road approaches to each work zone before any work commences. "Loose Gravel" (Type C6) with "15 MPH" subplate (Type W6) signs shall be posted on all streets receiving slurry seals. The Contractor shall provide temporary stands or poles on which to place the required signs.

Type C6 and W6 signs shall be furnished and placed adjacent to the traveled way for both directions of traffic on each block where chip/slurry seal screenings are being spread on a traffic lane. Additional signs shall be placed at maximum intervals of 500 feet and at intersections with roads entering the construction area as directed by the Engineer. The signs shall be maintained in place at each location until final sweeping of that location is completed.

#### **SP14-09 MEASUREMENT AND PAYMENT**

The lump-sum Contract Price paid for "**Traffic Control**" shall be considered as full compensation for furnishing all labor, supervision, materials, tools, equipment and incidentals needed to perform all traffic control work, for all phases of the work performed by the Contractor or the



Contractor's "subcontractors" including, but not limited to, all signs, barricades, steel plates, traffic control plan, detour plan, maintaining traffic, lane closures, detours, flagmen and all other traffic control devices; and all other work as shown on the State Standard Plans, as specified in the Standard Specifications, the State Specifications, these Special Provisions and as directed by the Engineer and no additional compensation shall be allowed therefor. There shall be no additional compensation for traffic control due to an increase in the quantities shown on the bid proposal for pay items within the project limits.

### **SPECIAL PROVISIONS SECTION SP-15**

#### **DUST CONTROL**

(NO BID ITEM)

The provisions of Section 4, "Dust Control and Watering," of the Technical Provisions of the Standard Specifications shall apply in their entirety and as supplemented herein.

#### **SP15-01 GENERAL**

The contract work occurs adjacent to existing residences. Contractor shall undertake all reasonable measures to minimize the presence and impacts of dust in the work area and on the adjacent residences.

Leaf blowers shall not be used to remove debris from the project streets. Debris removal shall be performed in such a way as to minimize dust.

Whenever the Engineer deems dust control to be necessary, the Contractor shall furnish and apply control measures to alleviate the problem. The Engineer shall specify a dust palliative or control measure in accordance with the provisions of the Standard Specifications, which the Contractor shall furnish and apply.

#### **SP15-02 PAYMENT**

No separate payment shall be made for conforming to the provisions of this section. Full compensation for conforming to all the provisions of this section shall be considered as included in the prices paid for various contract items of work and no additional compensation shall be allowed therefor.

### **SPECIAL PROVISIONS SECTION SP-16**

#### **CLEARING AND GRUBBING, TREE AND VEGETATION TRIMMING**

(BID ITEM NO. 3)

#### **SP16-01 GENERAL**

The provisions of Section 2, "Clearing and Grubbing," and Section 21, "Tree Trimming and Removal," of the Technical Provisions of the Standard Specifications shall apply in their entirety except as modified or supplemented herein.

The limits of clearing, grubbing, tree and vegetation trimming shall be sufficient to allow unobstructed access to the full width of the paved surface for the Contractor's workers and equipment to complete the Contract work, and to provide clear visibility to signs and similar facilities that require clear sight lines for intended users. Vegetation trimming shall provide for a minimum of 14 feet of vertical clearance above the paved surface of the road from edge of pavement or face of curb to edge of pavement or face of curb. The road surface shall also be cleared from edge of pavement or face of curb to edge of pavement or face of curb. The work shall include trimming vegetation at roadway intersections that obstructs sight distance at intersections. Vegetation shall be trimmed to a height of no greater than 30-inches above the ground for a distance of 25 feet on each leg of the intersection unless a lesser amount of trimming is directed by the engineer.

### **SP16-02 MEASUREMENT AND PAYMENT**

The lump-sum Contract Price paid for **"Clearing & Grubbing, Tree and Vegetation Trimming"** shall include full compensation for furnishing all labor, supervision, materials, tools, equipment and incidentals, and for doing all the work involved in clearing and grubbing, tree and vegetation trimming including, but not limited to, the removal and disposal of all existing trash, debris, rocks, shrubs and vegetation; trimming of shrubs, trees, and other vegetation and all other work as shown on the Plans, as specified in the Standard Specifications and these Special Provisions and as directed by the Engineer and no additional compensation shall be allowed therefor.

### **SPECIAL PROVISIONS SECTION SP-17 EXISTING HIGHWAY FACILITIES (BID ITEM NO. 8)**

### **SP17-01 GENERAL**

The work performed in connection with various existing highway facilities shall conform to the provisions of Section 7, "Existing Utilities" of the General Provisions and Section 22, "Protection and Restoration of Existing Improvements," of the Technical Provisions of the Standard Specifications, these Special Provisions, and as directed by the Engineer.

The Contractor shall fully document pre-construction conditions at all points around the work area. This documentation shall consist of notes, still photographs, and video. Special effort shall be made to document the existing conditions at all buildings and private improvements not to be disturbed.

All existing pavement markers, thermoplastic stripes, and legends within the micro-surfacing limits shall be completely removed immediately prior to sealing the roadway.

**SP17-02 STREET SWEEPING**

At the end of every work day, construction debris of any kind shall be swept from all surfaces within the areas affected by the Contractor's operations. Failure to conform to these provisions shall be ground for suspension of work per Section 8-3 of the General Provisions.

**SP17-03 REMOVALS**

Contractor's attention is directed to Section 6-11, "General Safety," of the General Provisions of the Standard Specifications regarding safety around excavated areas.

Existing highway facilities to be removed under this section and as shown on the Plans shall include, but not be limited to removing traffic striping, markings, and markers. These items shall be removed and disposed of in accordance with Section 6-16, "Disposal Outside Project Limits," of the General Provisions of the Standard Specifications.

Pavement markers, stripes, or legends which are removed shall be replaced with temporary markers, stripes, and legends prior to opening the roadway to vehicular or pedestrian traffic. Pavement delineation removal shall conform to the provisions of Section 15-4, "Removal of Existing and Temporary Stripes and Pavement Markings," of the Technical Provisions of the Standard Specifications. Removal by sandblasting shall not be allowed. Attention also is directed to Special Provisions Section SP-26, "Temporary Pavement Delineation," of these Special Provisions.

**SP17-04 MEASUREMENT AND PAYMENT**

Full compensation for locating and marking utilities and the preparation of utility reference point plans shall be considered as included in the Contract Price paid for various contract items of work and no additional compensation shall be allowed therefor.

The lump-sum Contract Price paid for "**Remove Existing Pavement Markers and Thermoplastic Stripes and Legends**" shall be considered as full compensation for furnishing all labor, materials, tools, equipment and incidentals necessary to remove and dispose of pavement markers, stripes and legends, as specified in the Standard Specifications, the State Specifications and these Special Provisions, and as directed by the Engineer, and no additional compensation shall be allowed therefore.

**SPECIAL PROVISIONS SECTION SP-18 (NOT USED)****SPECIAL PROVISIONS SECTION SP-19****ASPHALT PAVEMENT**

(BID ITEM NO. 4,5)

**SP19-01 GENERAL**

The provisions of Section 5, "Street Failed Area Repair," of the Technical Provisions of the Standard Specifications shall apply in their entirety except as modified or supplemented herein.

Asphalt Concrete requirements shall be as described in Section 9, "Asphalt Concrete" of the Technical Provisions of the Standard Specifications and these Special Provisions.

Asphalt Concrete shall be placed in accordance with Section 9-5 "Placement" of Technical Provisions of the Standard Specification. Type A,  $\frac{3}{4}$ " maximum sized aggregate (MSA) asphalt shall be used for all pavement repairs.

Section 9.3.2 RAP Considered a Value-Engineering Change Proposal of the Standard Specification shall not apply.

**SP19-02 PAVEMENT REPAIR AREA**

Paint markings delineating the approximate size and location of the pavement repair areas have been made in the field on streets included in this Contract. The Contractor shall submit a request for any re-marking in writing five (5) working days in advance of beginning pavement repair work. Actual quantities may be greater or less than the quantities shown on the Bid Schedule.

In areas designated for "Pavement Repair" as marked in the field by the Engineer, the existing base and bituminous surfacing shall be removed by cold planing, or sawcutting and excavating to the depth shown on the contract plans. Pavement repair areas shall be a minimum of 4-feet in width. Pavement removed beyond the limits designated by the Engineer shall be considered to be for the Contractor's convenience and shall be at no additional expense to the City. The excavated area shall be backfilled with asphalt concrete, compacted, and finished as shown on the Plans and as specified in these Special Provisions.

**SP19-06 MEASUREMENT AND PAYMENT**

The contract unit price paid per square foot for "**Pavement Repair (6-inch)**" and "**Pavement Repair (3-inch)**" shall include full compensation for furnishing all labor, supervision, materials, tools, equipment and incidentals and for doing all the work involved including, but not limited to, cold planing, sawcutting, excavating, loading, off hauling, disposing of materials, subgrade preparation and compaction, tack coat, and furnishing, placing, spreading, and compacting the asphalt concrete to the specified depth and all other work as shown on the Plans, as specified in the Standard Specifications, the State Specifications and these Special Provisions, and as directed by the Engineer, and no additional compensation shall be allowed therefor.

**SPECIAL PROVISIONS SECTION SP-20****CRACK SEALING****(BID ITEM NO. 6)**

**SP20-01 GENERAL**

The provisions of Section 12-2, "Crack Fill Repairs," of the Technical Provisions of the Standard Specifications shall apply in their entirety except as modified or supplemented herein.

**SP20-02 MATERIALS**

The Contractor shall submit certificates from suppliers stating compliance of materials with the requirements of this section.

Crack sealing shall be performed after pavement repairs are completed and prior to chip sealing or micro-surfacing.

The asphalt-rubber shall be heated to a minimum temperature of 325°F, but not greater than 390°F, or as specified by the manufacturer and as approved by the Engineer. The material shall be held in the mixing tank at application temperature until very little separation of the rubber and asphalt occurs when a bead of sealant material is placed on the pavement. Sealant material may be added to the mix as long as the minimum temperature of 325°F is maintained. Asphalt rubber binder shall be applied when atmospheric temperature is between 60°F and 105°F, and pavement surface temperature is between 75°F and 140°F.

Sand used to cover sealed cracks for opening to traffic shall be black "Kleen Blast" sand as available from White Cap Construction Supply, Concord, CA, or approved equal.

In areas to receive a chip seal treatment, in lieu of materials specified in the Standard Specifications, Contractor shall use a non-rubberized crack sealant, such as Crafcro Superflex HT Polymer Modified, or approved equal. Said sealant shall conform to the following requirements:

Test	Test Method	Specification
Softening Point	ASTM D36	210°F minimum
Cone Penetration @ 77°F	ASTM 5329	45 maximum
Flow @ 140°F	ASTM D5329	0 mm

Cracks greater than 1 inch in width shall be repaired with fine hot-mix asphalt Type B, No. 4 filler, conforming to State Specifications. Contractor shall submit a mix design for this material for approval prior to use.

### **SP20-03 MEASUREMENT AND PAYMENT**

The lump-sum Contract Price paid for “**Crack Seal**” shall be considered as full compensation for furnishing all labor, materials, tools, equipment and incidentals and for doing all the work involved in crack sealing, including, but not limited to, routing, blowing, crack filling, sanding and clean-up, and all other work, as shown on the Plans, as specified in the Standard Specifications and these Special Provisions, and as directed by the Engineer and no additional compensation shall be allowed therefor.

## **SPECIAL PROVISIONS SECTION SP-21**

### **SEAL COAT**

(BID ITEM NO. 7)

### **SP21-01 GENERAL**

The provisions of Section 10-1 of the Technical Provisions of the Standard Specifications shall apply in their entirety for all seal coat work, except as modified or supplemented herein.

Sand used for blotting seal coats to open work area to traffic shall be black “Kleen Blast” sand as available from White Cap Construction Supply, Concord, CA, or approved equal.

### **SP21-02 SLURRY SEAL**

Slurry Seal shall conform to Section 10-2 of the Technical Provisions of the Standard Specifications.

Mineral filler shall be added to the aggregate at the maximum rate of 2.5 percent by weight of the dry aggregate, only if required by the mix design. Portland cement, if used, shall be commercially available Type I-II and shall be free of lumps and clods.

Water shall be free of harmful, soluble salts and shall be of such quality that the asphalt shall not separate from the emulsion before the emulsion mix is in place in the work. If necessary for workability, a set-control agent that will adversely affect the micro-surfacing project may be used.

### **Materials**

**Slurry Seal** – Emulsion for shall be a polymer modified cationic quickset (PMCQS-1h), shall be homogenous and shall conform to the provisions of these special provisions. The polymer shall be milled or blended into the asphalt or blended into the emulsifier solution prior to the emulsification process. Polymer solids must be a minimum of 3.0% by weight of the emulsion’s residual asphalt. Provide a certificate of compliance certifying the amount of polymer.

**Mixing, Production, and Quality Control**

Aggregate, mineral filler, PMCQS-1h, water, and additives, including the set-control agent, if used, shall be proportioned by volume utilizing the mix design approved by the Engineer.

**Placing**

**Slurry Seal shall be spread at the rate of 14-18 lbs. of dry aggregate per square yard.**

After the initial break of the micro surfacing and within a maximum of 2 hours after placement the slurry seal shall be rolled with a pneumatic tire roller meeting the-following requirements:

- Pneumatic - 9.3 tons minimum weight
- Pneumatic - The roller shall be equipped with 7 total wheels, 4 in the rear and 3 in the front of the roller with an equipped water sprayer system.

The roller shall make a minimum of three complete passes on the surface prior to the road being opened to traffic

Slurry seal shall be traffic ready within 60 minutes of being applied to roadway surface. The term "Traffic Ready" means allowing uncontrolled traffic on the roadway surface.

Placement of the slurry seal shall cease a minimum of two hours before the expiration of the road closure hours as specified in "Maintaining Traffic" of these special provisions, unless the Contractor proves to the satisfaction of the Engineer that the surface will be ready for unrestricted traffic at the expiration of the road closure hours.

**SP21-03 TOLERANCES**

Tolerances for individual materials, as well as the bituminous seal coat mixtures, are as follows:

- 1) After the designed residual point asphalt content is determined, a one percentage point (1%) variation will be permitted.
- 2) The percent of aggregate passing each sieve shall not vary more than 4.0% from the Job Mix Formula (JMF).
- 3) The percent of aggregate passing shall not go from the high end to the low of the specified range of any two successive sieves.
- 4) The slurry consistency shall not vary more than 0.5 cm from the JMF after field adjustments.
- 5) The average rate of application of the seal coat mixture shall not be less than the specified rate when measured for any contiguous area of 5,000 square feet. When the

total theoretical volume of seal coat mixture is less than that calculated at the minimum application rate, the contract price shall be reduced proportionately.

#### **SP21-05 MEASUREMENT AND PAYMENT**

The contract unit price paid per square yard “**Slurry Seal, Type II**” shall be considered as full compensation for furnishing all labor, materials, tools, equipment and incidentals and for doing all the work involved in micro-surfacing with or without fiber, including but not limited to; site preparation, cleanup, protecting utility and manhole covers, applying slurry seal, rolling, protection during curing, street sweeping and all other incidental work required to complete the work as shown and specified.

**SPECIAL PROVISIONS SECTION SP-22 (NOT USED)**  
**SPECIAL PROVISIONS SECTION SP-23 (NOT USED)**  
**SPECIAL PROVISIONS SECTION SP-24 (NOT USED)**  
**SPECIAL PROVISIONS SECTION SP-25 (NOT USED)**

#### **SPECIAL PROVISIONS SECTION SP-26** **TEMPORARY PAVEMENT DELINEATION** (BID ITEM NO. 9)

#### **SP26-01 GENERAL**

Work shall conform to Section 6-12.7 “Temporary Traffic Striping and Pavement Markings,” of the General Provisions of the Standard Specifications and Section 15-4 of the Technical Provisions of the Standard Specifications.

Nothing in these Special Provisions shall be construed as relieving the Contractor from his/her responsibilities as specified in said sections. Any traffic striping or markings that are removed due to any phase of work shall be replaced, or re-aligned if required, with temporary traffic stripes or pavement markings. All temporary striping and markings shall be placed the same day the permanent striping or markings are removed and they shall be placed before opening the roadway to public traffic.

#### **SP26-02 MEASUREMENT AND PAYMENT**

The lump-sum Contract Price paid for “**Temporary Pavement Delineation**” shall include full compensation for furnishing all labor, supervision, materials, tools, equipment and incidentals and for doing all the work necessary to lay out, place, maintain, and remove temporary pavement striping, legends, arrows, glue down delineators, markers and markings and all other work as shown on the Plans, as specified in the State Specifications and these Special Provisions, and as directed by the Engineer and no additional compensation shall be allowed therefor.



**SPECIAL PROVISIONS SECTION SP-27**  
**PAVEMENT STRIPING, MARKERS AND DELINEATION**  
(BID ITEM NOS. 10-26)

**SP27-01 GENERAL**

The provisions of Section 15, "Pavement Striping, Markers, and Delineation," of the Technical Specifications of the Standard Specifications shall apply in their entirety except as modified or supplemented herein.

Traffic striping and marking shall be placed in accordance with the applicable details as shown on applicable State Standard Plans. Detail numbers shown on the Plans and the Bid Schedule refers to details shown in the State Standard Plans.

Temporary "cat tracking" and layout marks shall be placed by the Contractor for all striping (including limit lines and crosswalks) that was removed. Temporary "cat tracks" shall be approved by the Engineer prior to final striping. No payment will be made for any striping performed without notification to the City and advance approval of layout marks by the Engineer.

**SP27-02 THERMOPLASTIC AND PAINT TRAFFIC STRIPES AND PAVEMENT LEGENDS AND MARKINGS**

All limit lines, centerline stripes, shoulder stripes, and legends shall be thermoplastic unless otherwise indicated on the Plans or directed by the Engineer.

Thermoplastic traffic stripes and pavement marking shall conform to the provisions of Section 84-2, "Thermoplastic Traffic Stripes and Pavement Markings," of the State Specifications, and these Special Provisions.

During thermoplastic placement, the Contractor shall use traffic control as specified in Section SP14, "Traffic Control," of these Special Provisions.

**SP27-03 MEASUREMENT AND PAYMENT**

Traffic stripes shall be measured by the linear foot along the line of the traffic stripe without deductions for the gaps, shown on the standard details. Deductions shall be made for gaps in the striping at cross streets and driveways.

Measurement for legends and markings shall be per the areas shown on State Standard Plans.

The Contract Prices paid per linear foot for **various stripes, striping details and curb painting**, per square foot for **"Thermoplastic Pavement Legends & Markings,"** and per each for **"Two-Way Reflective Pavement Markers (Blue)"** shall include full compensation for furnishing all labor, materials, tools, equipment, and incidentals, including any necessary cat tracks, dribble lines and layout work; and all other work as shown on the Plans, the State Standard Plans, and as specified in these Special Provisions, and as directed by the Engineer, and no additional compensation shall be allowed therefor.

# APPENDICES

# **APPENDIX A**

## **WASTE MANAGEMENT PLAN INSTRUCTIONS**



## Planning & Building Department

3675 Mt. Diablo Boulevard, Suite 210  
Lafayette, CA 94549-1968  
Tel. (925) 284-1976 • Fax (925) 284-1122  
<http://www.ci.lafayette.ca.us>

### WASTE MANAGEMENT PLAN INSTRUCTIONS CONSTRUCTION AND DEMOLITION DEBRIS RECYCLING

#### GENERAL

The City of Lafayette is mandated by the State of California to divert 65-percent of all solid waste from landfills either by salvage or recycling. To help meet this goal, the City requires completion of a Waste Management Plan (WMP) for covered projects identifying how at least 65-percent of project waste materials will be diverted from the landfill. A “covered project” is defined as:

1. **Residential**
  - All newly constructed buildings,
  - All demolition-only projects,
  - All projects where the addition or alteration is 1,000 sq. ft. or larger,
  - All projects where the project valuation is >\$50,000 (with the exception of reroof-only projects).
2. **Non-Residential:** All projects.

#### GREEN HALO SYSTEMS

For a covered project, applicants are required to submit their WMP to the City using Green Halo Systems. Green Halo is a free web-based service for waste diversion and recycling tracking. Through Green Halo, applicants can establish, monitor and document their waste management plan and compliance online. Applicants can set-up a Green Halo account at [www.lafayette.wastetracking.com](http://www.lafayette.wastetracking.com). For applicants who do not have access to the internet, Green Halo can set-up an account over the phone at **1-888-525-1301**. Once an applicant has created a Green Halo account, they can track and manage multiple projects for different jurisdictions on their account.

#### PROCEDURE

Prior to issuance of a grading, demolition, and/or building permit for a covered project:

1. Submit a non-refundable administrative fee, payable to the City of Lafayette. See “[Planning Fees](#)” handout for current rate.
2. Submit a WMP to the City using Green Halo that includes the following:
  - a) Identification of all the **materials** you estimate will be recycled, salvaged, or disposed; and
  - b) Identification of which [certified C&D facilities](#) the various material types will go.
3. Green Halo will notify the City that a WMP has been submitted. The City will review the submitted WMP on Green Halo. The WMP will only be approved when all of the following conditions have been met:
  - a) The WMP provides all information noted above; and
  - b) The WMP indicates that at least 65-percent of all construction and demolition debris generated by the project will be diverted.
4. The WMP will be approved or not approved. If the WMP is incomplete and/or fails to meet the required diversion rate, the WMP will not be approved and the applicant will be notified about the reasons for non-approval. No grading, building, and/or demolition permit will be issued until the WMP is approved.

#### INFEASIBILITY EXEMPTION

If an applicant for a covered project experiences unique circumstances that make it infeasible to comply with the diversion requirement, the applicant may apply for an exemption at the time the WMP is submitted. Increased costs to the applicant generally will not be a sufficient basis for an exemption. The applicant shall indicate on the WMP

the minimum rate of diversion he/she believes is feasible for each material and the specific circumstances that he/she believes make it infeasible to comply with the diversion requirement.

#### **UPON COMPLETION OF THE PROJECT**

Prior to the final inspection of a grading, demolition, and/or building permit and within 30 days after project completion, the applicant shall submit their WMP to the City through Green Halo for final review. The goal of the final review is to provide documentation to the City showing that the diversion requirement has been met. Please note that all receipts for the project shall be submitted. The WMP submitted for final review shall include the following:

1. Receipts from the certified facilities that collected or received each material showing the actual volume or weight of the material received and how the material was disposed of; and
2. Any additional information the applicant believes is relevant to determining its efforts to comply in good faith with the diversion requirement.

Through Green Halo, the City will review the WMP and documentation noted above and a determination will be made if the applicant has complied with the diversion requirement as follows:

1. **Full compliance** - If the applicant has fully complied with the diversion requirement.
2. **Good Faith Effort to Comply** - If the diversion requirement has not been achieved, the City will determine on a case-by-case basis whether the applicant has made a good faith effort to comply with the diversion requirement. In making this determination, the City will consider the availability of markets for the C&D debris landfilled, the size of the project and the documented efforts of the applicant to divert the C&D debris.
3. **Noncompliance** - If the City determines that the applicant has not complied with the diversion requirement, the City may withhold final project approval until full compliance can be established.

**No hold on final shall be released, until the WMP has been provided to and approved by the City as either full compliance or good faith effort to comply.**

#### **NONCOMPLIANCE**

Please note that if the required documentation is not submitted and approved by the City, or the applicant has not made a good faith effort to comply, the applicant is in noncompliance status and is in violation of the Lafayette Municipal Code (LMC) and is liable for a civil penalty, or any other remedy provided in the LMC. This violation makes the property owner liable to the City for a civil penalty of \$1,000 or one percent (1%) of the project cost, whichever is less. The project will not be approved and holds will not be released, until the project is in full compliance, meets the good faith effort to comply, or the civil penalty has been paid.

#### **APPEAL**

Appeal of the determination made by the City shall be made to the City Council within 30 days of the City's determination. To appeal, an applicant must submit a letter to the city manager concisely stating the facts of the case and the grounds of appeal. The city manager will schedule a meeting before the city council and notify the applicant of the date, time, and place. The decision of the city council is final. Appeals shall be limited to:

1. The granting or denial of an exemption; or
2. Whether the applicant has made a good faith effort to comply with the WMP.

**NOTE:** The applicant and property owner are responsible for the actions of their contractors or other agents with regard to the diversion requirement. Therefore, when reviewing proposals from project managers, contractors, site cleanup, vendors, and other building professionals, all aspects of the proposal should be considered and not just the cost.

The facilities that are certified through GreenHalo for processing recycled materials may also process landfilled waste. The applicant is responsible for indicating to the facility that the waste should be recycled. Before leaving a facility, the applicant should verify that the ticket lists the correct recycled material (e.g. "Mixed C&D"). If the ticket lists "MSW" (Municipal Solid Waste), this means the materials were landfilled and there is a 0% diversion rate.

**APPENDIX B**

**STANDARD PLANS**

### CENTERLINES (2 LANE HIGHWAYS)

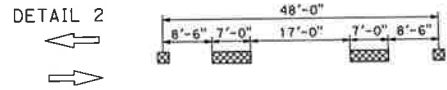
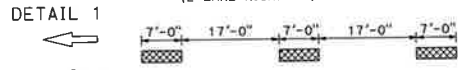

~~DETAIL 3~~      DETAIL 3 DELETED

~~DETAIL 4~~      DETAIL 4 DELETED

### LANELINES (Cont)

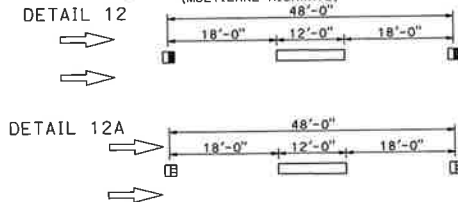

~~DETAIL 13~~      DETAIL 13 DELETED

~~DETAIL 14~~      DETAIL 14 DELETED

~~DETAIL 14A~~      DETAIL 14A DELETED

### NO PASSING ZONES-TWO DIRECTION

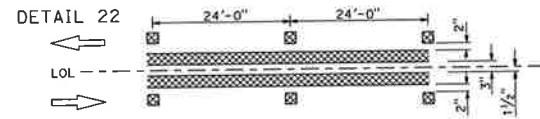

~~DETAIL 23~~      DETAIL 23 DELETED

### NO PASSING ZONES-ONE DIRECTION

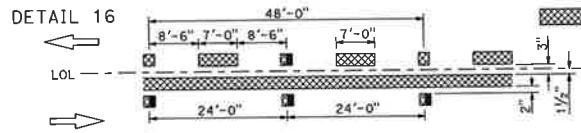
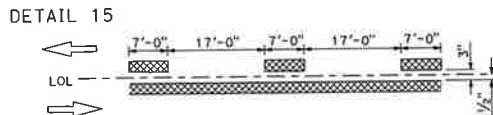

~~DETAIL 17~~      DETAIL 17 DELETED

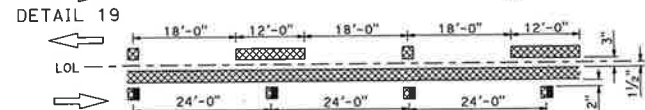
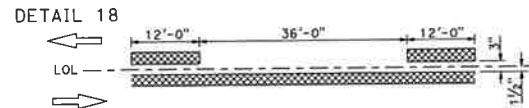

~~DETAIL 20~~      DETAIL 20 DELETED

### LANELINES

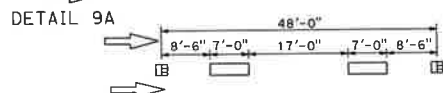
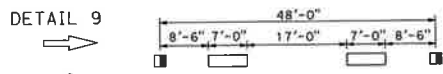

~~DETAIL 10~~      DETAIL 10 DELETED

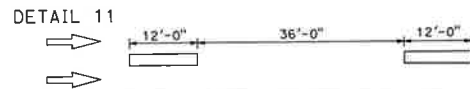

### LEGEND

#### MARKERS

- TYPE C RED-CLEAR RETROREFLECTIVE
- TYPE D TWO-WAY YELLOW RETROREFLECTIVE
- TYPE G ONE-WAY CLEAR RETROREFLECTIVE
- TYPE H ONE-WAY YELLOW RETROREFLECTIVE

#### LINES

- 6" WHITE
- 6" YELLOW

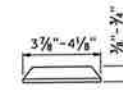
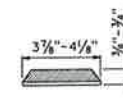

TYPE C AND TYPE D

TYPE G AND TYPE H

RETROREFLECTIVE FACE

STATE OF CALIFORNIA  
DEPARTMENT OF TRANSPORTATION  
**PAVEMENT MARKERS AND TRAFFIC LINES**  
TYPICAL DETAILS  
NO SCALE

**A20A**

Dist.	COUNTY	ROUTE	POST MILES TOTAL PROJECT	SHEET No. TOTAL SHEETS
			August 1, 2022 PLANS APPROVAL DATE	
THE STATE OF CALIFORNIA OR ITS OFFICERS OR AGENTS SHALL NOT BE RESPONSIBLE FOR THE ACCURACY OR COMPLETENESS OF SCANNED COPIES OF THIS PLAN SHEET.				

2022 STANDARD PLAN A20A

### LEFT EDGE LINES

(DIVIDED HIGHWAYS)  
See Note

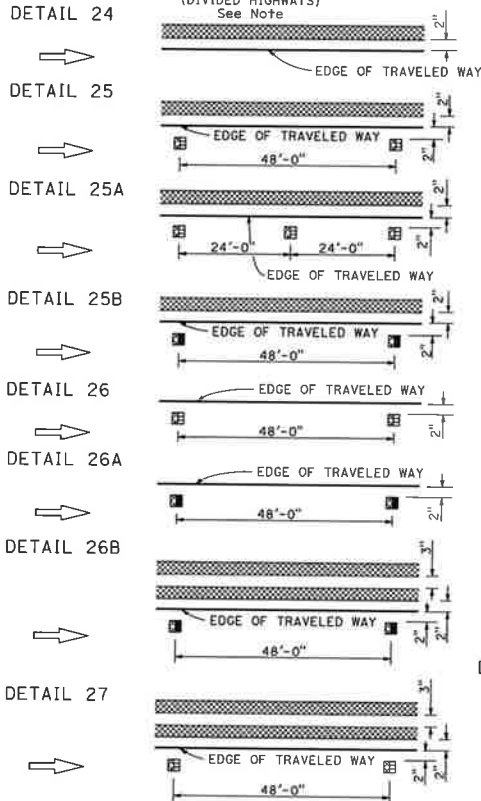

### RIGHT EDGE LINES

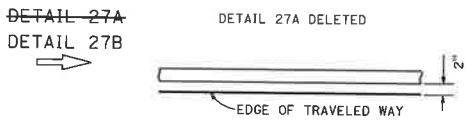

### RIGHT EDGE LINE EXTENSION THROUGH INTERSECTIONS

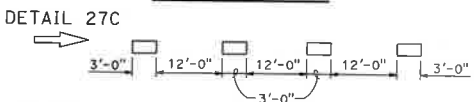

LEFT EDGE LINES NOTE:  
On freeways use traffic stripe details with Type RY markers.

### MEDIAN ISLANDS

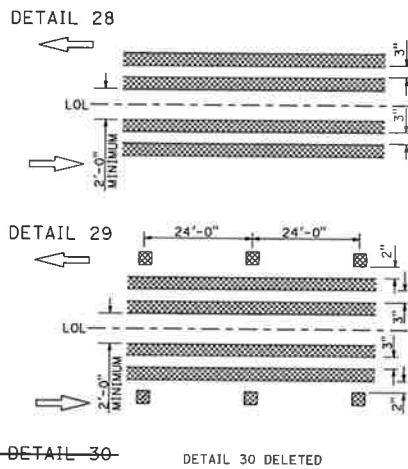

### TWO-WAY LEFT TURN LANES

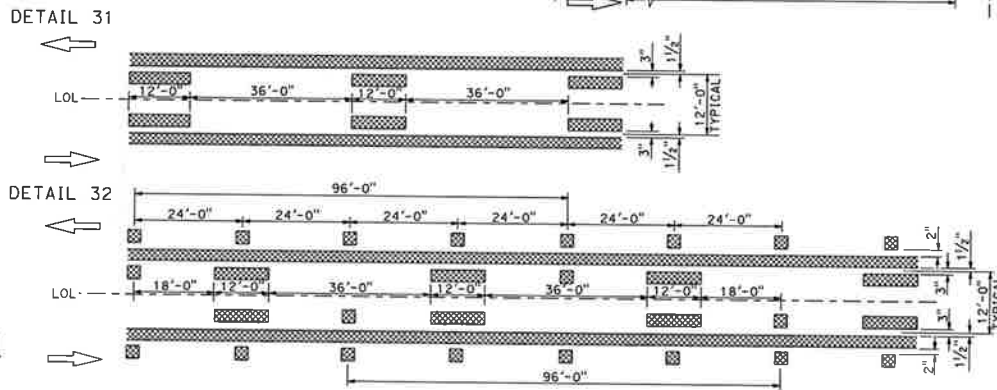

DETAIL 33: DETAIL 33 DELETED

### LEGEND

- MARKERS
- TYPE D TWO-WAY YELLOW RETROREFLECTIVE
  - TYPE H ONE-WAY YELLOW RETROREFLECTIVE
  - TYPE RY RED-YELLOW RETROREFLECTIVE
- LINES
- 6" WHITE
  - 6" YELLOW

### INTERSECTION TREATMENTS

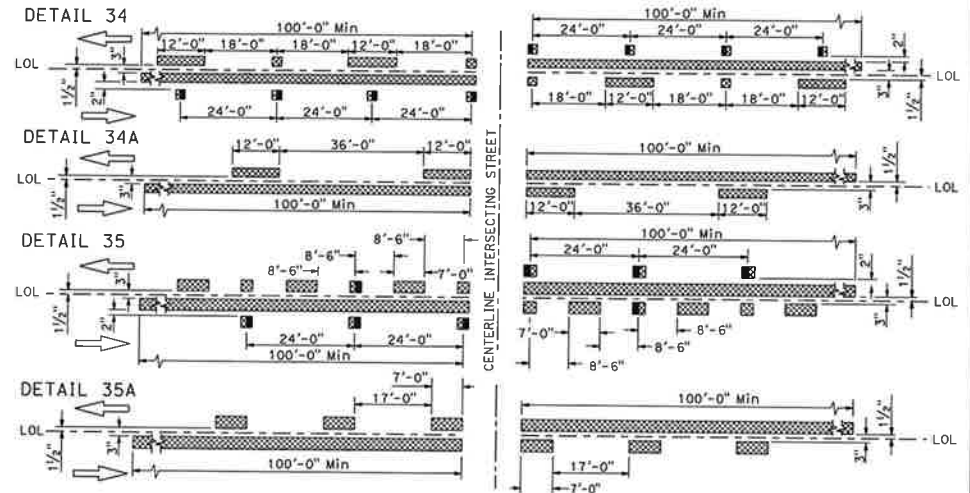

### MARKER DETAILS

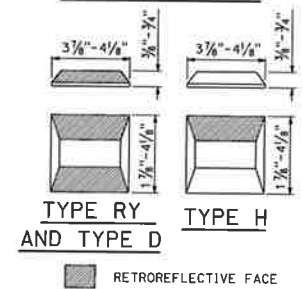

STATE OF CALIFORNIA  
DEPARTMENT OF TRANSPORTATION  
**PAVEMENT MARKERS AND TRAFFIC LINES**  
**TYPICAL DETAILS**

NO SCALE

A20B

Dist	COUNTY	ROUTE	POST MILES TOTAL PROJECT	SHEET No.	TOTAL SHEETS

*Leif Hahn*  
REGISTERED CIVIL ENGINEER

August 1, 2022  
PLANS APPROVAL DATE

THE STATE OF CALIFORNIA OR ITS OFFICERS OR AGENTS SHALL NOT BE RESPONSIBLE FOR THE ACCURACY OR COMPLETENESS OF SCANNED COPIES OF THIS PLAN SHEET.

REGISTERED PROFESSIONAL ENGINEER  
Law J. Roper  
C48132  
Exp. 9-30-22  
CIVIL  
STATE OF CALIFORNIA



DIST	COUNTY	ROUTE	POST MILES TOTAL PROJECT	(SHEET NO.) TOTAL SHEETS

  

<i>Leopold Huber</i> REGISTERED CIVIL ENGINEER No. 699132 Exp. 9-30-22 CIVIL STATE OF CALIFORNIA		
August 1, 2022 PLANS APPROVAL DATE THE STATE OF CALIFORNIA OR ITS OFFICERS OR AGENTS SHALL NOT BE RESPONSIBLE FOR THE ACCURACY OR COMPLETENESS OF SCANNED COPIES OF THIS PLAN SHEET.		

### EXIT RAMP NEUTRAL AREA (GORE) TREATMENT

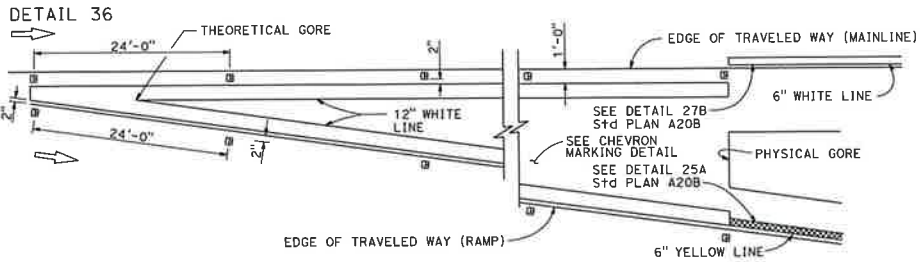

### ENTRANCE RAMP NEUTRAL AREA (MERGE) TREATMENT

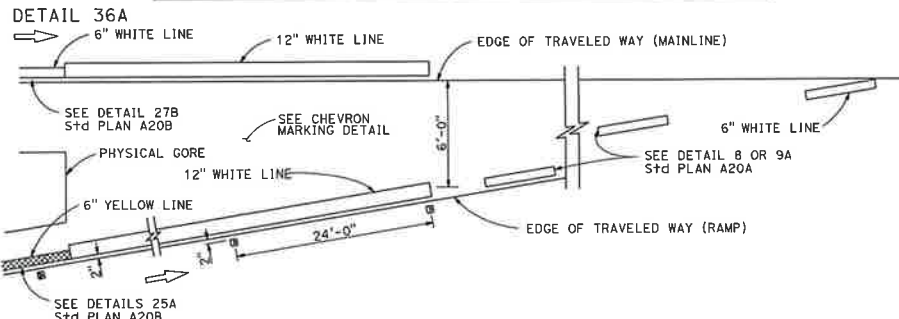

### ENTRANCE RAMP NEUTRAL AREA (ACCELERATION LANE) TREATMENT

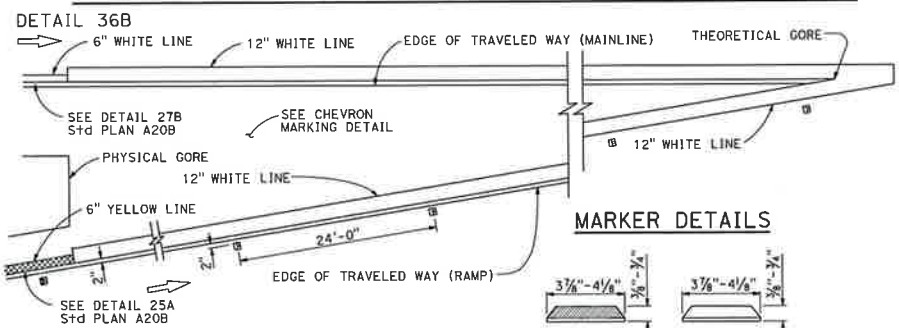

### MARKER DETAILS

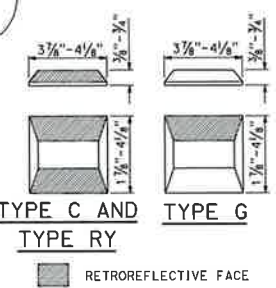

- LEGEND:**
- MARKERS**
- TYPE C RED-CLEAR RETROREFLECTIVE
  - TYPE G ONE-WAY CLEAR RETROREFLECTIVE
  - TYPE RY RED-YELLOW RETROREFLECTIVE

### NOTES:

Install a minimum of 1 chevron in the gore area. If at least 1 chevron will not fit into the gore area, do not install chevrons. Terminate chevron markings at physical gore. Gore area chevron pavement markings shown. For Exit and Entrance Ramp channelizing lines details, see Details 36, 36A, and 36B.

### LANE DROP AT EXIT RAMP

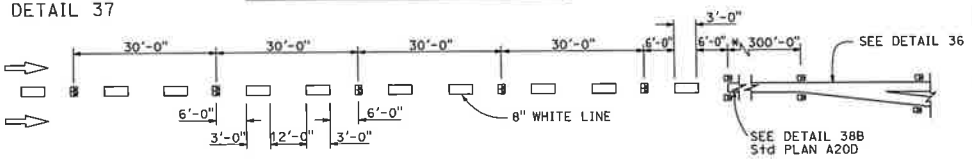

\* The solid channelizing line shown may be omitted on short auxiliary lanes where weaving length is critical.

~~DETAIL 37A~~ DETAIL 37A DELETED

### LANE DROP AT INTERSECTIONS

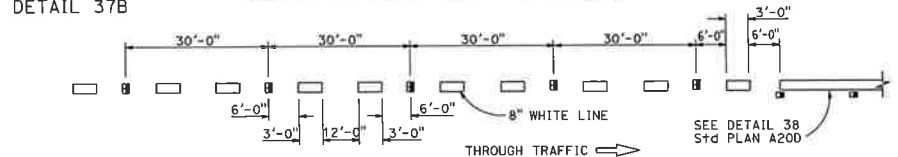

~~DETAIL 37C~~ DETAIL 37C DELETED

### CHEVRON PAVEMENT MARKINGS AT EXIT RAMP GORE AREA

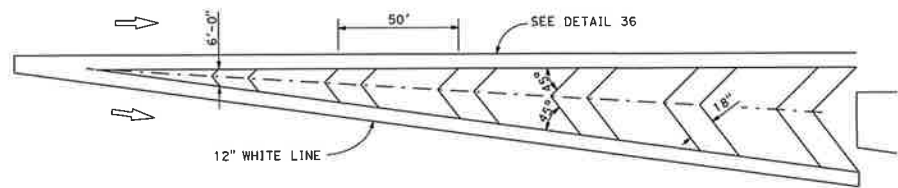

### CHEVRON PAVEMENT MARKINGS AT ENTRANCE RAMP GORE AREA

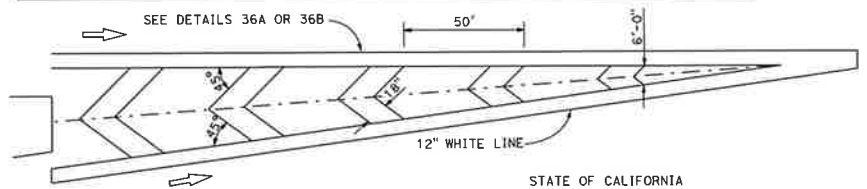

## PAVEMENT MARKERS AND TRAFFIC LINES TYPICAL DETAILS

STATE OF CALIFORNIA  
DEPARTMENT OF TRANSPORTATION

NO SCALE

**A20C**

2022 STANDARD PLAN A20C

### CHANNELIZING LINE

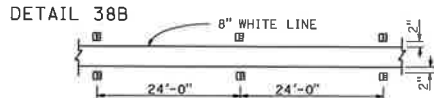
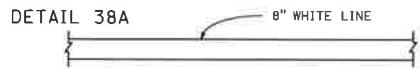
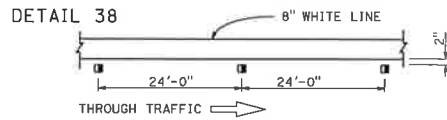

~~DETAIL 38C~~      ~~DETAIL 38C DELETED~~

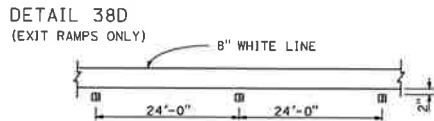

### BIKE LANE LINE



### INTERSECTION LINE BIKE LANE

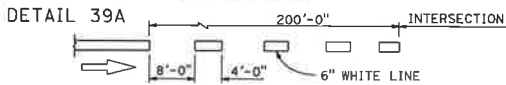

### LANE LINE EXTENSIONS THROUGH INTERSECTIONS

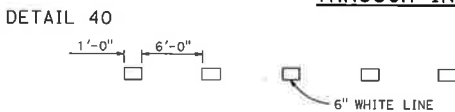

~~DETAIL 40A~~      ~~DETAIL 40A DELETED~~

### CENTER LINE EXTENSIONS THROUGH INTERSECTIONS

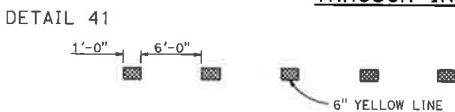

~~DETAIL 41A~~      ~~DETAIL 41A DELETED~~

### LEGEND

#### MARKERS

- TYPE C RED-CLEAR RETROREFLECTIVE
- TYPE G ONE-WAY CLEAR RETROREFLECTIVE

6" YELLOW LINE

### MARKER DETAILS

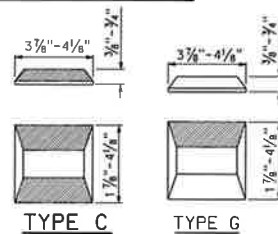

RETROREFLECTIVE FACE

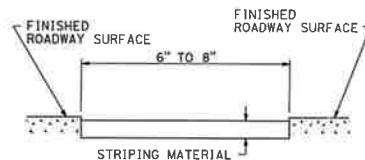

### DETAIL FOR RECESSED TRAFFIC STRIPE

See Notes A and B

#### RECESSED NOTES:

- A. See typical traffic line details for pavement marking patterns.
- B. See standard specifications for recess depth and recess striping material thickness.

DIST.	COUNTY	ROUTE	POST MILES TOTAL PROJECT	SHEET NO.	TOTAL SHEETS

*Les J. Huber*  
REGISTERED CIVIL ENGINEER

August 1, 2022  
PLANS APPROVAL DATE

THE STATE OF CALIFORNIA OR ITS OFFICERS OR AGENTS SHALL NOT BE RESPONSIBLE FOR THE ACCURACY OR COMPLETENESS OF SCANNED COPIES OF THIS PLAN SHEET.

REGISTERED PROFESSIONAL ENGINEER  
LES J. HUBER  
No. C49132  
Exp. 9-30-22  
TITLE

STATE OF CALIFORNIA

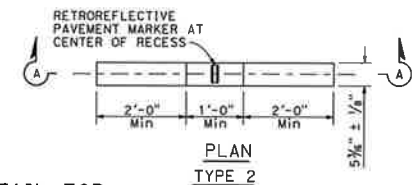
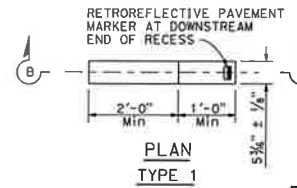
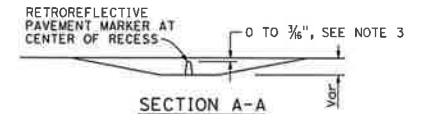
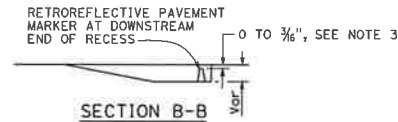

### RECESS DETAIL FOR RETROREFLECTIVE PAVEMENT MARKER

See Note 4

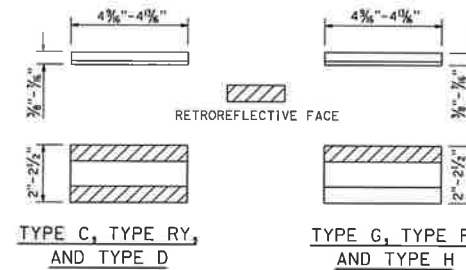

#### RECESSED MARKER NOTES:

1. See typical traffic line details for marker patterns to be used with recessed pavement markers.
2. The retroreflective pavement markers shown for recessed installations are not to be used for non-recessed installations.
3. The top of pavement markers installed in recesses shall be 0 to 3/16" below the pavement surface.
4. Use Type 1 recess for pavement markers with one-way retroreflective face. Use Type 2 recess for pavement markers with two-way retroreflective face.

### RETROREFLECTIVE PAVEMENT MARKER FOR RECESSED INSTALLATION

See Notes 1 and 2

STATE OF CALIFORNIA  
DEPARTMENT OF TRANSPORTATION  
**PAVEMENT MARKERS AND TRAFFIC LINES  
TYPICAL DETAILS**

NO SCALE

**A20D**

DIST	COUNTY	ROUTE	POST MILES TOTAL PROJECT	SHEET TOTAL NO. SHEETS
<i>Lee J. Hober</i> REGISTERED CIVIL ENGINEER				
August 1, 2022 PLANS APPROVAL DATE				
<small>THE STATE OF CALIFORNIA OR ITS OFFICERS OR AGENTS SHALL NOT BE RESPONSIBLE FOR THE ACCURACY OR COMPLETENESS OF SCANNED COPIES OF THIS PLAN SHEET.</small>				



**NOTE:**

1. See Standard Plans A20A, A20B, A20C, A20D, and A20F for pavement markers and traffic lines typical details.



TYPICAL LANE LINE OR RIGHT EDGE LINE CONTRAST DETAIL

STATE OF CALIFORNIA  
 DEPARTMENT OF TRANSPORTATION  
**PAVEMENT MARKERS AND TRAFFIC LINES  
 TYPICAL DETAIL FOR CONTRAST STRIPING**  
 NO SCALE

**A20E**

2022 STANDARD PLAN A20E

**PREFERENTIAL LANE LINES**

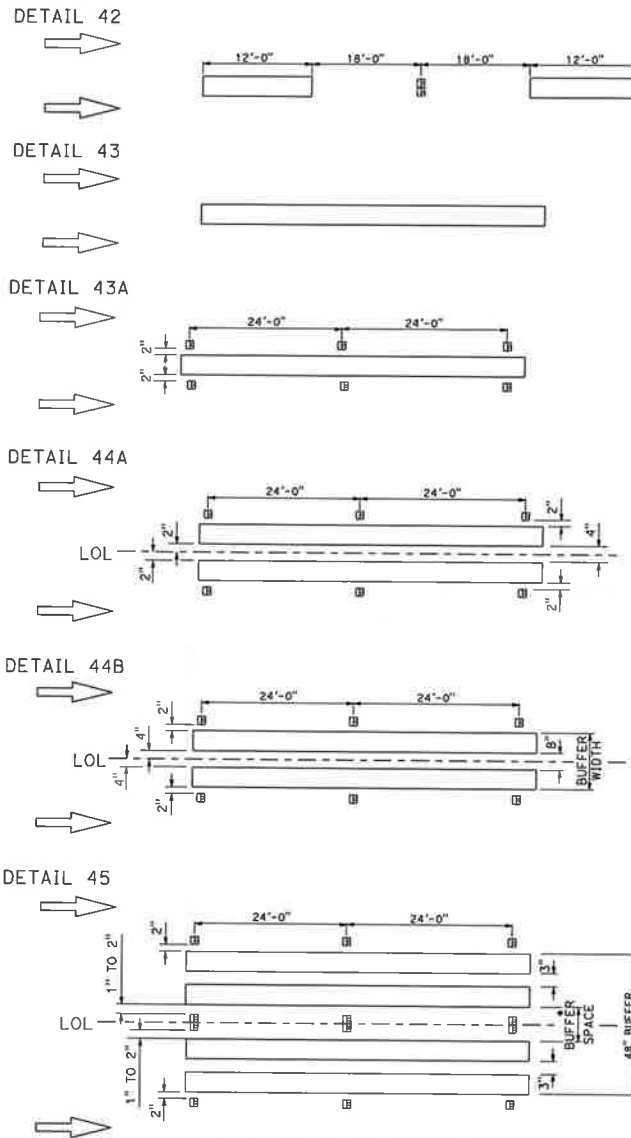

\* If buffer space is wider than 4 feet use chevron markings.

**LEGEND**

**MARKERS**

☐ TYPE C RED-CLEAR RETROREFLECTIVE

**LINES**

▭ 8" WHITE LINE

**MARKER DETAILS**

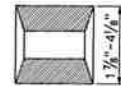
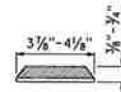

**TYPE C**

▣ RETROREFLECTIVE FACE

DIST	COUNTY	ROUTE	POST MILES TOTAL PROJECT	SHEET NO.	TOTAL SHEETS

Lee J. Hober  
 REGISTERED CIVIL ENGINEER

August 1, 2022  
 PLANS APPROVAL DATE

Lee J. Hober  
 No. C49132  
 Exp. 8-30-22  
 (CIVIL)  
 STATE OF CALIFORNIA

THE STATE OF CALIFORNIA OR ITS OFFICERS OR AGENTS SHALL NOT BE RESPONSIBLE FOR THE ACCURACY OR COMPLETENESS OF SCANNED COPIES OF THIS PLAN SHEET.

STATE OF CALIFORNIA  
 DEPARTMENT OF TRANSPORTATION  
**PAVEMENT MARKERS AND TRAFFIC LINES**  
**TYPICAL DETAILS**  
 NO SCALE

**A 20F**

**NOTES:**

1. May be a limit line or crosswalk.
2. See Standard Plans A24F and A24G for crosswalk and pavement marker details.
3. Place Type R one-way red retroreflective markers on outermost limit line or crosswalk line with red facing the intersection.
4. The distances and marker spacings may be adjusted based on site specific conditions or exit ramp geometry.
5. The layout shown is a typical detail of an exit ramp, see Figure 3B-24 of the CA MUTCD for exit ramp configuration and arrow placement and spacing.
6. See Standard Plan A24G for Type V arrow detail with Type R one-way red retroreflective markers.

DIST	COUNTY	ROUTE	POST MILES TOTAL PROJECT	SHEET NO.	TOTAL SHEETS

*Lee J. Haber*  
 REGISTERED CIVIL ENGINEER  
 August 1, 2022  
 PLANS APPROVAL DATE  
 No. C49332  
 Exp. 3-30-22  
 CIVIL  
 STATE OF CALIFORNIA  
 REGISTERED PROFESSIONAL ENGINEER

THE STATE OF CALIFORNIA OR ITS OFFICERS OR AGENTS SHALL NOT BE RESPONSIBLE FOR THE ACCURACY OR COMPLETENESS OF SCANNED COPIES OF THIS PLAN SHEET.

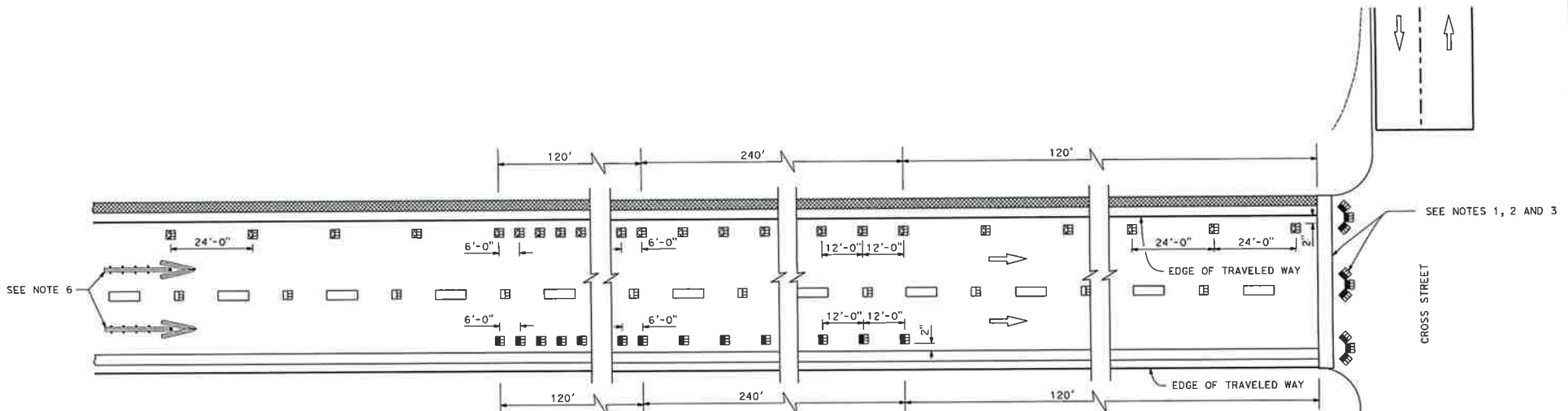

**LEGEND:**

**MARKERS**

- TYPE C TWO-WAY RED-CLEAR RETROREFLECTIVE
- TYPE RY TWO-WAY RED-YELLOW RETROREFLECTIVE
- TYPE R ONE-WAY RED RETROREFLECTIVE

**LINES**

- 6" WHITE
- 6" YELLOW

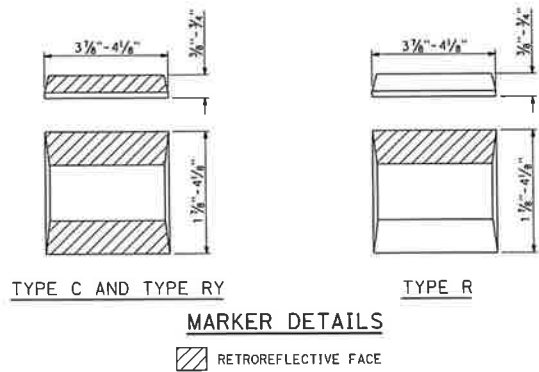

STATE OF CALIFORNIA  
 DEPARTMENT OF TRANSPORTATION  
**EXIT RAMP WITH ENHANCED PAVEMENT MARKERS FOR WRONG WAY DETAILS**  
 NO SCALE

**A20G**

**2022 STANDARD PLAN A20G**

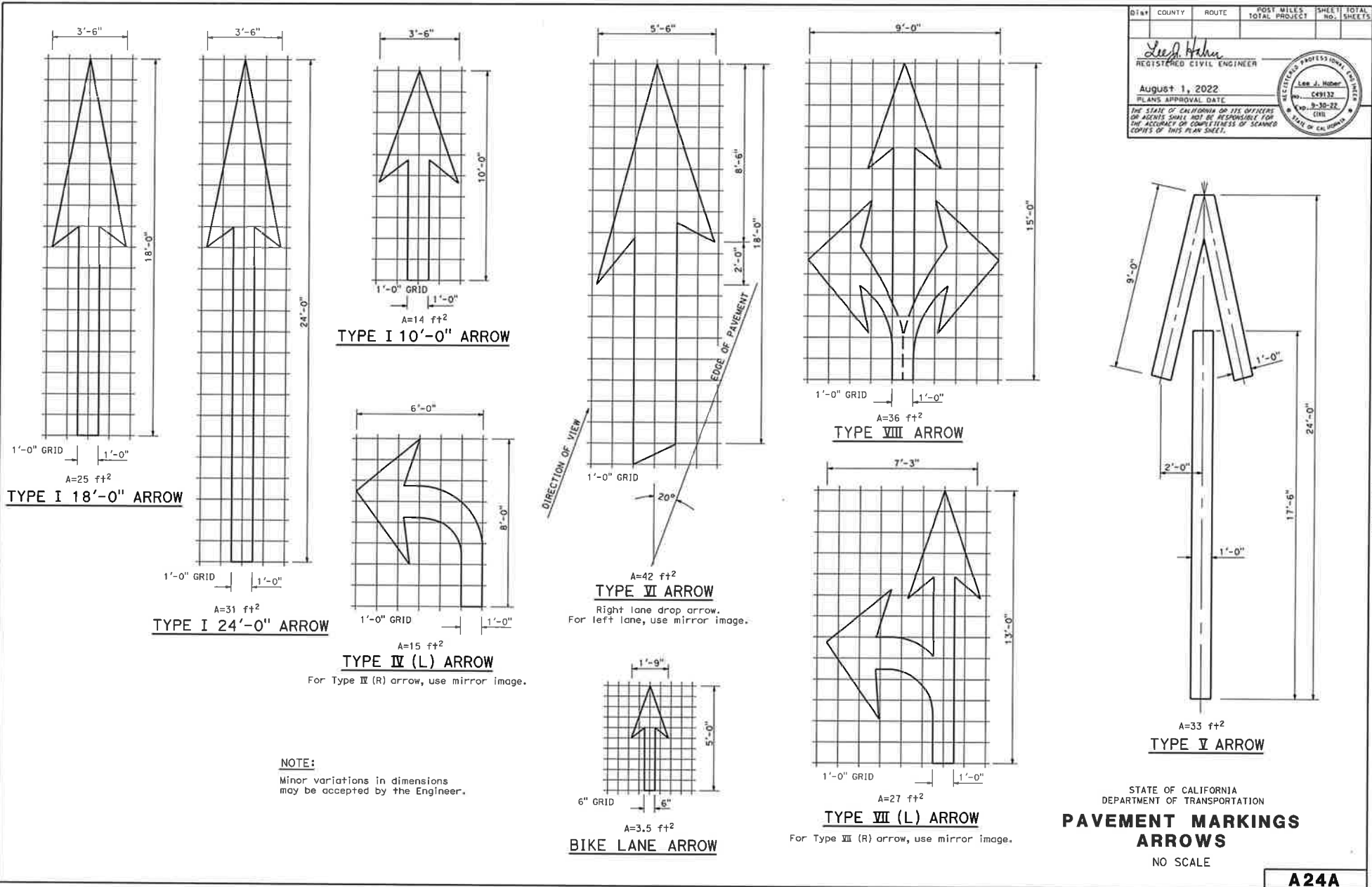

DIST.	COUNTY	ROUTE	POST MILES TOTAL PROJECT	SHEET NO.	TOTAL SHEETS

*Lee J. Hober*  
 REGISTERED CIVIL ENGINEER  
 August 1, 2022  
 PLANS APPROVAL DATE  
 THE STATE OF CALIFORNIA OR ITS OFFICERS OR AGENTS SHALL NOT BE RESPONSIBLE FOR THE ACCURACY OR COMPLETENESS OF SCANNED COPIES OF THIS PLAN SHEET.

LICENSED PROFESSIONAL ENGINEER  
 No. C49132  
 Exp. 9-30-22  
 (EIR)  
 STATE OF CALIFORNIA

2022 STANDARD PLAN A24A

**A24A**



DIST.	COUNTY	ROUTE	POST MILES TOTAL PROJECT	SHEET NO.	TOTAL SHEETS
<i>Leah Haber</i> REGISTERED CIVIL ENGINEER					
August 1, 2022 PLAN'S APPROVAL DATE					
THE STATE OF CALIFORNIA OR ITS OFFICERS OR AGENTS SHALL NOT BE RESPONSIBLE FOR THE ACCURACY OR COMPLETENESS OF SCANNED COPIES OF THIS PLAN SHEET.					

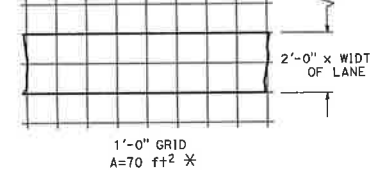
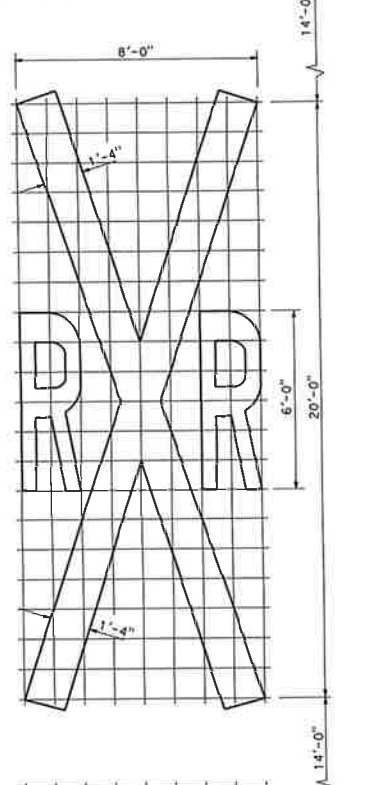
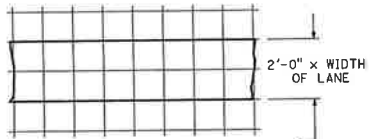

**RAILROAD CROSSING SYMBOL**

\* To ft<sup>2</sup> does not include the 2'-0" x variable width transverse lines.

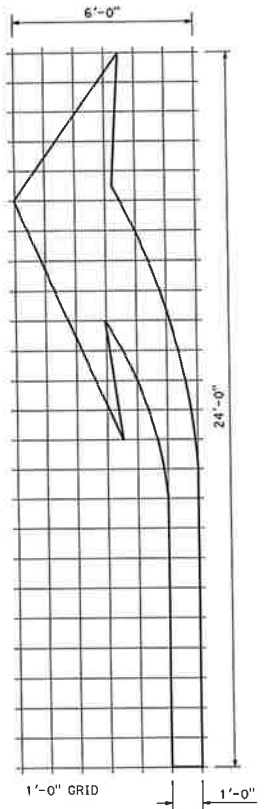

A=42 ft<sup>2</sup>  
**TYPE III (L) ARROW**  
 For Type III (R) use mirror image.

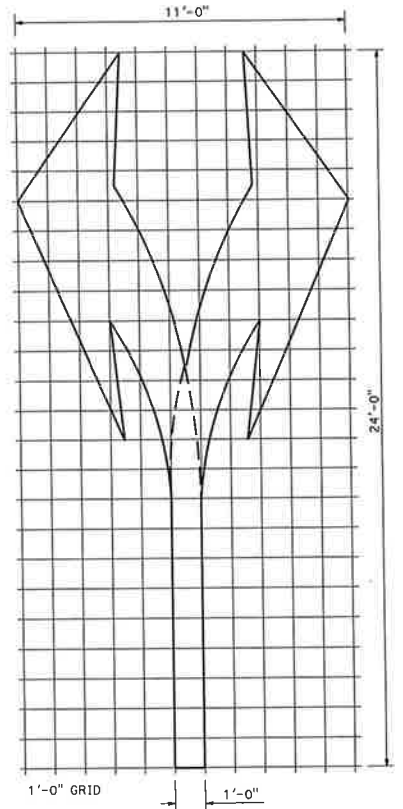

A=73 ft<sup>2</sup>  
**TYPE III (B) ARROW**

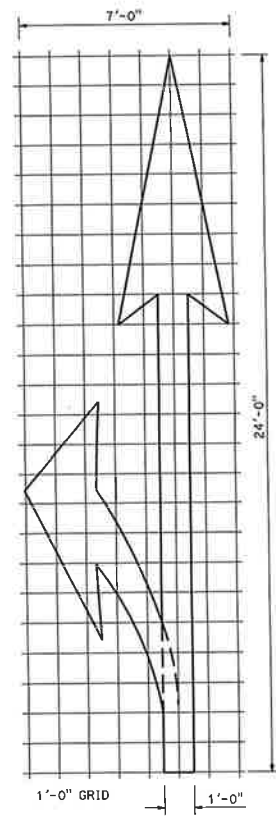

A=45 ft<sup>2</sup>  
**TYPE II (L) ARROW**  
 For Type II (R) use mirror image.

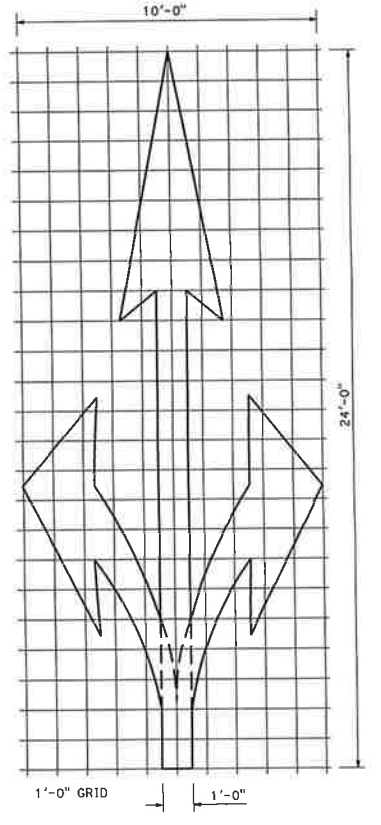

A=59 ft<sup>2</sup>  
**TYPE II (B) ARROW**

**NOTE:**  
 Minor variations in dimensions may be accepted by the Engineer.

STATE OF CALIFORNIA  
 DEPARTMENT OF TRANSPORTATION  
**PAVEMENT MARKINGS  
 ARROWS AND SYMBOLS**  
 NO SCALE

**A24B**

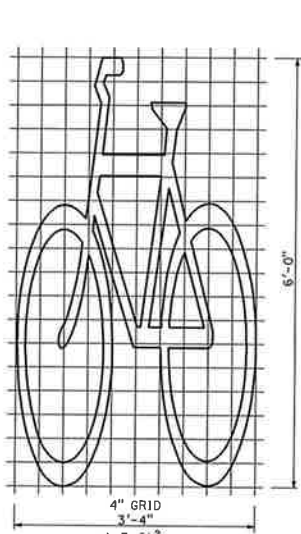

**BIKE LANE SYMBOL  
WITHOUT PERSON**

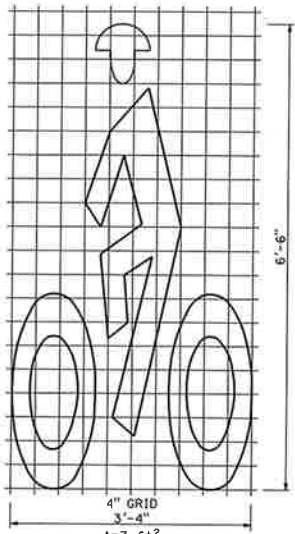

**BIKE LANE SYMBOL  
WITH PERSON**

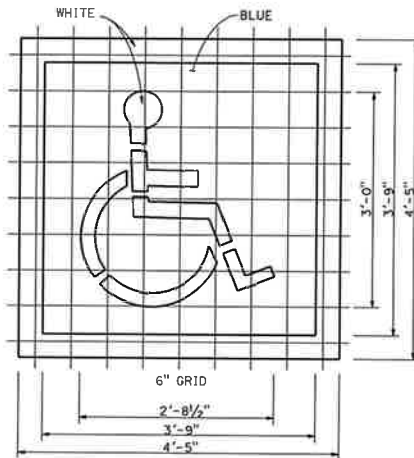

**INTERNATIONAL SYMBOL OF  
ACCESSIBILITY (ISA) MARKING**

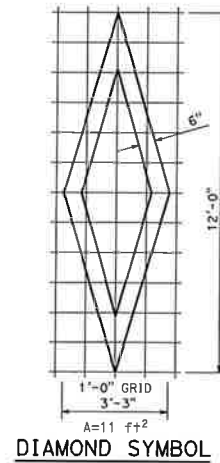

**DIAMOND SYMBOL**

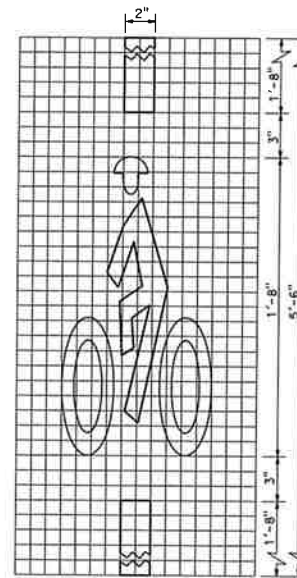

**BICYCLE LOOP  
DETECTOR SYMBOL**

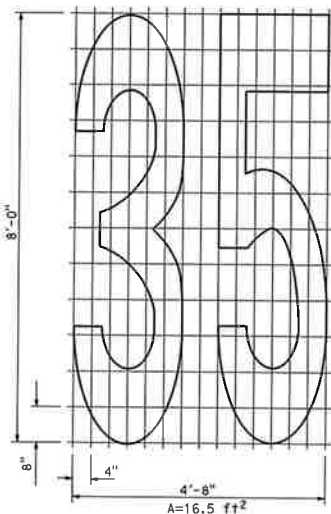
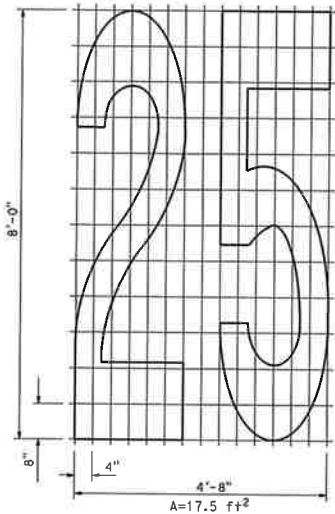

**NUMERALS**

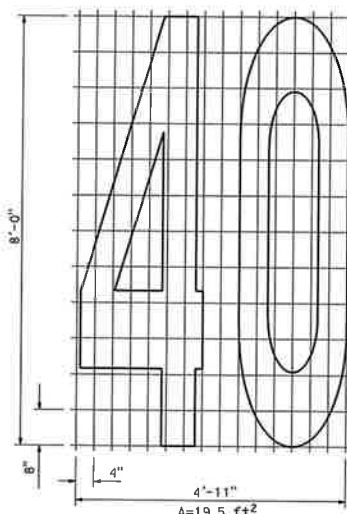

Dist	COUNTY	ROUTE	POST MILES TOTAL PROJECT	SHEET No.	TOTAL SHEETS

*Leah Heber*  
REGISTERED CIVIL ENGINEER

August 1, 2022  
PLANS APPROVAL DATE

THE STATE OF CALIFORNIA OR ITS OFFICERS OR AGENTS SHALL NOT BE RESPONSIBLE FOR THE ACCURACY OR COMPLETENESS OF SCANNED COPIES OF THIS PLAN SHEET.

REGISTERED PROFESSIONAL ENGINEER  
Leah J. Heber  
No. C49132  
Exp. 8-30-22  
(T11)  
STATE OF CALIFORNIA

**NOTE:**  
Minor variations in dimensions may be accepted by the Engineer.

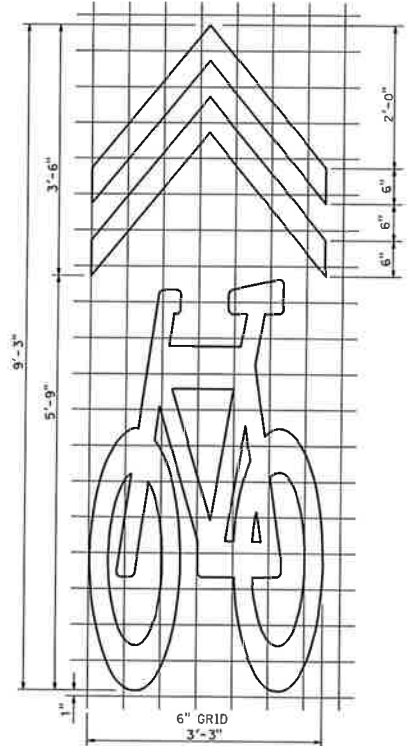

**SHARED ROADWAY BICYCLE MARKING**

STATE OF CALIFORNIA  
DEPARTMENT OF TRANSPORTATION  
**PAVEMENT MARKINGS  
SYMBOLS AND NUMERALS**  
NO SCALE

**A24C**



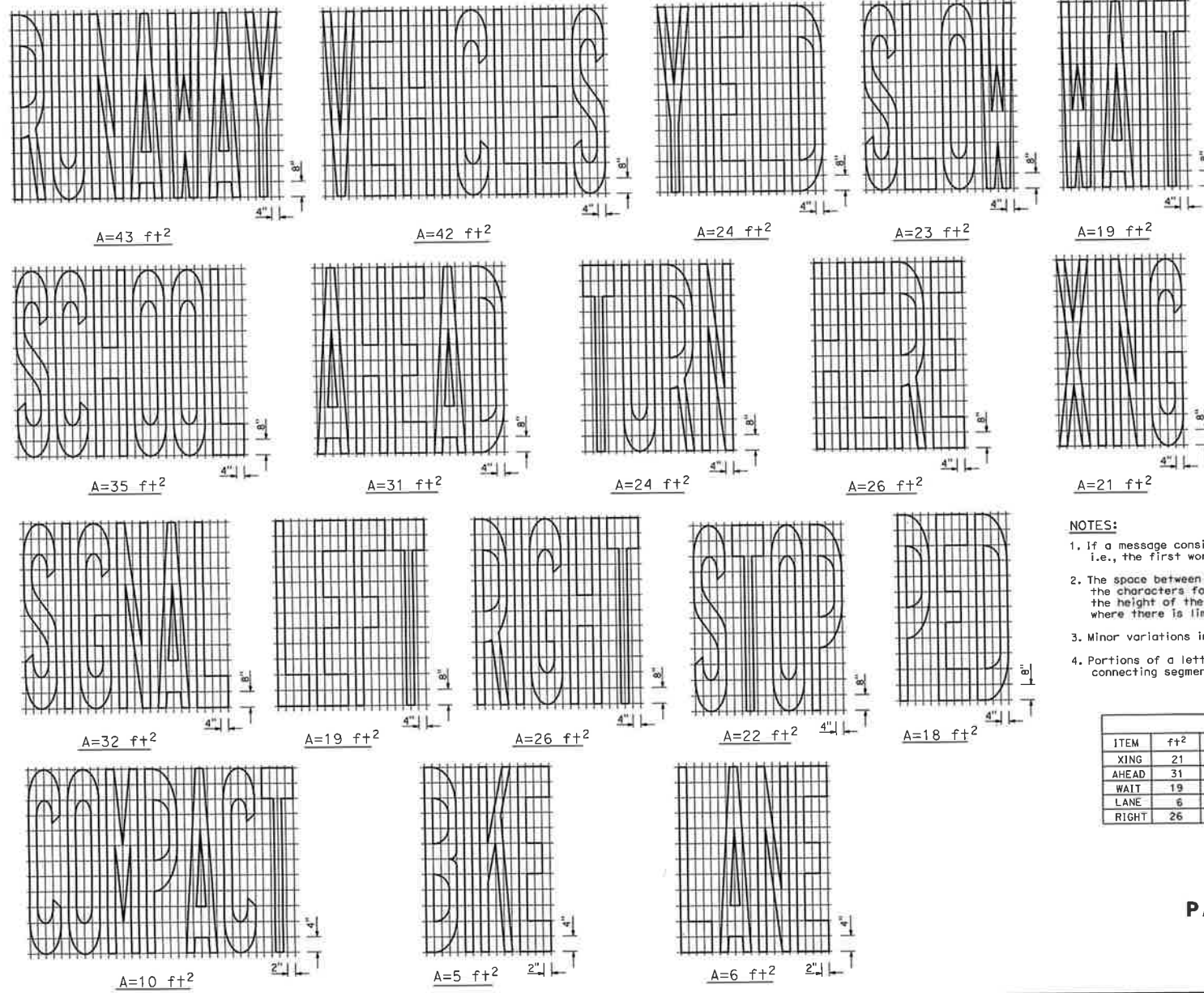

DIST	COUNTY	ROUTE	POST MILES TOTAL PROJECT	SHEET NO.	TOTAL SHEETS

*Leslie Haber*  
REGISTERED CIVIL ENGINEER

August 1, 2022  
PLANS APPROVAL DATE

THE STATE OF CALIFORNIA OR ITS OFFICERS OR AGENTS SHALL NOT BE RESPONSIBLE FOR THE ACCURACY OR COMPLETENESS OF SCANNER COPIES OF THIS PLAN SHEET.

REGISTERED PROFESSIONAL ENGINEER  
Les J. Mosby  
C49132  
Exp. 8-30-22  
EIRB  
STATE OF CALIFORNIA

- NOTES:**
1. If a message consists of more than one word, it must read "UP", i.e., the first word must be nearest the driver.
  2. The space between words must be at least four times the height of the characters for low speed roads, but not more than ten times the height of the characters. The space may be reduced appropriately where there is limited space because of local conditions.
  3. Minor variations in dimensions may be accepted by the Engineer.
  4. Portions of a letter, number or symbol may be separated by connecting segments not to exceed 2" in width.

WORD MARKINGS							
ITEM	ft²	ITEM	ft²	ITEM	ft²	ITEM	ft²
XING	21	YIELD	24	BIKE	5	PED	18
AHEAD	31	SCHOOL	35	SLOW	23	COMPACT	10
WAIT	19	SIGNAL	32	STOP	22	RUNAWAY	43
LANE	6	TURN	24	LEFT	19	VEHICLES	42
RIGHT	26	HERE	26				

STATE OF CALIFORNIA  
DEPARTMENT OF TRANSPORTATION  
**PAVEMENT MARKINGS  
WORDS**  
NO SCALE

**A24D**

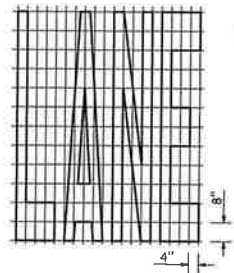

A=24 ft<sup>2</sup>

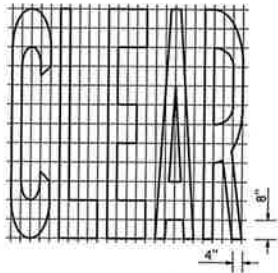

A=27 ft<sup>2</sup>

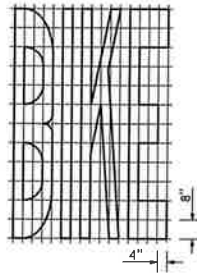

A=21 ft<sup>2</sup>

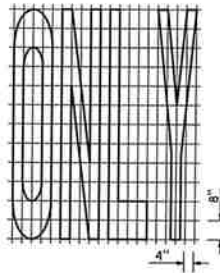

A=22 ft<sup>2</sup>

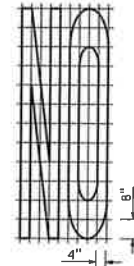

A=14 ft<sup>2</sup>

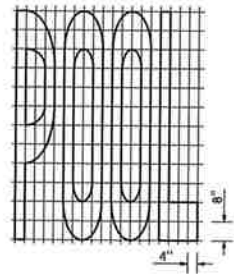

A=23 ft<sup>2</sup>

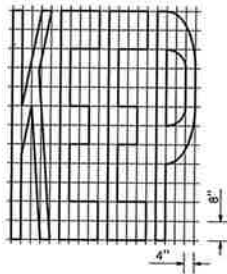

A=24 ft<sup>2</sup>

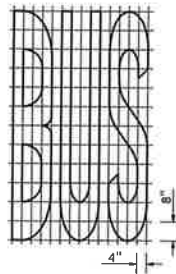

A=20 ft<sup>2</sup>

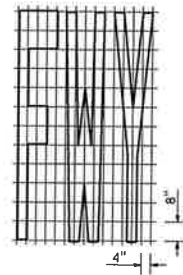

A=16 ft<sup>2</sup>

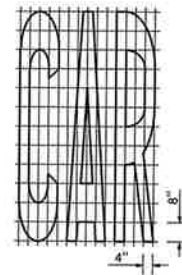

A=17 ft<sup>2</sup>

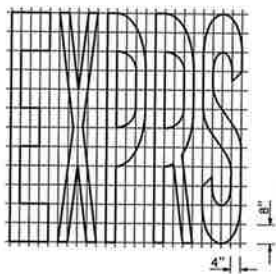

A=30 ft<sup>2</sup>

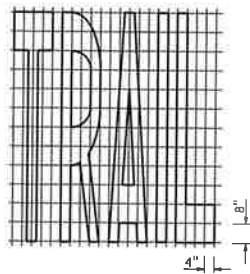

A=23 ft<sup>2</sup>

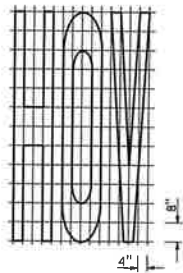

A=18 ft<sup>2</sup>

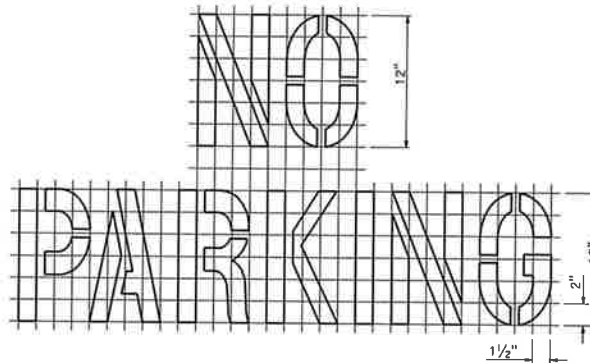

A=2 ft<sup>2</sup>

See Notes 5 and 6

Dist.	COUNTY	ROUTE	POST MILES TOTAL PROJECT	SHEET NO.	TOTAL SHEETS

*Lee Hahn*  
REGISTERED CIVIL ENGINEER

August 1, 2022  
PLANS APPROVAL DATE

THE STATE OF CALIFORNIA OR ITS OFFICERS OR AGENTS SHALL NOT BE RESPONSIBLE FOR THE ACCURACY OR COMPLETENESS OF SCANNED COPIES OF THIS PLAN SHEET.

REGISTERED PROFESSIONAL ENGINEER  
Lee J. Hoober  
No. C49132  
Exp. 8-30-22  
CECIL  
STATE OF CALIFORNIA

WORD MARKINGS			
ITEM	ft <sup>2</sup>	ITEM	ft <sup>2</sup>
LANE	24	NO	14
POOL	23	BIKE	21
CAR	17	BUS	20
CLEAR	27	ONLY	22
KEEP	24	FWY	16
MOV	18	EXPRS	30
TRAIL	23		

**NOTES:**

- If a message consists of more than one word, it must read "up", i.e., the first word must be nearest the driver.
- The space between words must be at least four times the height of the characters for low speed roads, but not more than ten times the height of the characters. The space may be reduced appropriately where there is limited space because of local conditions.
- Minor variations in dimensions may be accepted by the Engineer.
- Portions of a letter, number or symbol may be separated by connecting segments not to exceed 2" in width.
- The words "NO PARKING" pavement marking is to be used for parking facilities. For typical locations of markings, see Standard Plans A90A and A90B.
- The words "NO PARKING", shall be painted in white letters no less than 1'-0" high on a contrasting background and located so that it is visible to traffic enforcement officials.

STATE OF CALIFORNIA  
DEPARTMENT OF TRANSPORTATION

**PAVEMENT MARKINGS  
WORDS**

NO SCALE

**A 24E**

DIST.	COUNTY	ROUTE	POST MILES TOTAL PROJECT	SHEET NO.	TOTAL SHEETS
<i>Lee J. Hobbs</i> REGISTERED CIVIL ENGINEER					
August 1, 2022 PLANS APPROVAL DATE					
<small>THE STATE OF CALIFORNIA AND ITS OFFICERS OR AGENTS SHALL NOT BE RESPONSIBLE FOR THE ACCURACY OR COMPLETENESS OF SCANNED COPIES OF THIS PLAN SHEET.</small>					

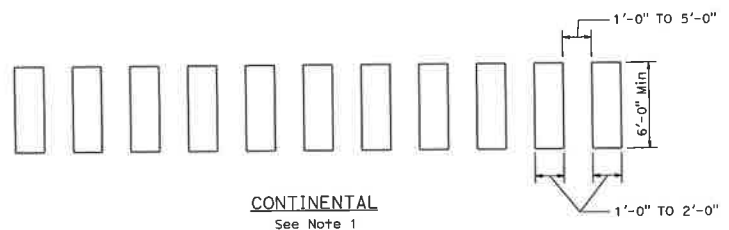

**CONTINENTAL**  
See Note 1

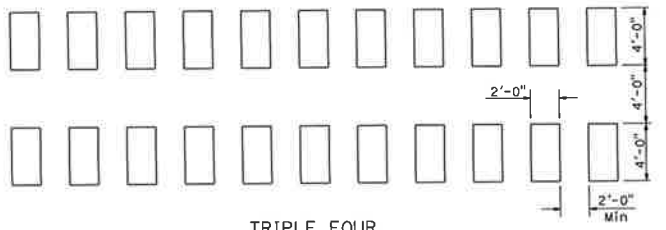

**TRIPLE FOUR**  
See Note 1

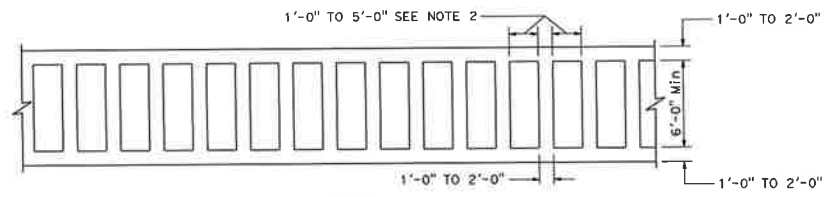

**LADDER**

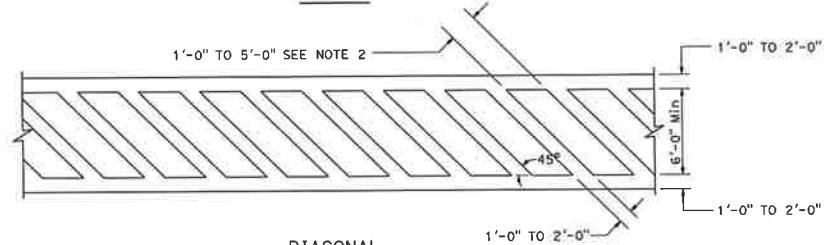

**DIAGONAL**

**HIGHER VISIBILITY CROSSWALKS**

**NOTES:**

1. Spaces between markings must be placed in wheel tracks of each lane.
2. Spacings not to exceed 2.5 x width of longitudinal line.
3. All crosswalk markings must be white except those near schools must be yellow.

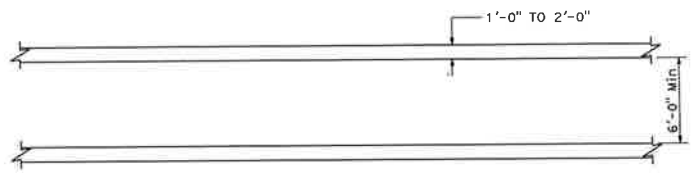

**BASIC**

STATE OF CALIFORNIA  
DEPARTMENT OF TRANSPORTATION  
**PAVEMENT MARKINGS  
CROSSWALKS**  
NO SCALE

**A24F**

2022 STANDARD PLAN A24F

DIST	COUNTY	ROUTE	POST MILES TOTAL PROJECT	SHEET TOTAL SHEETS

*Lee J. Hahn*  
 REGISTERED CIVIL ENGINEER  
 August 1, 2022  
 PLANS APPROVAL DATE  
 THE STATE OF CALIFORNIA OR ITS OFFICERS OR AGENTS SHALL NOT BE RESPONSIBLE FOR THE ACCURACY OR COMPLETENESS OF SCANNED COPIES OF THIS PLAN SHEET.

Lee J. Hahn  
 C49132  
 No. 9-30-22  
 (111)  
 STATE OF CALIFORNIA

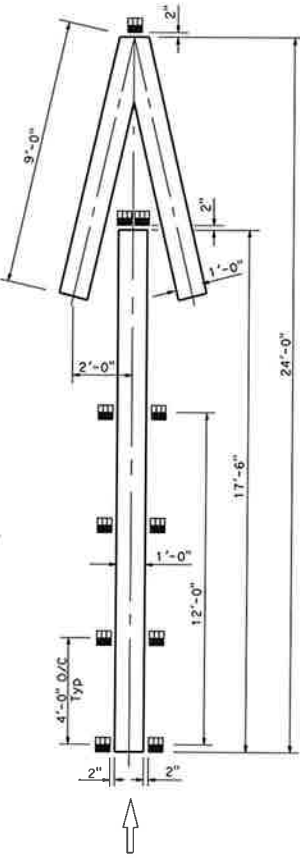

$A=33 f+2$

**TYPE V ARROW AT EXIT RAMP**

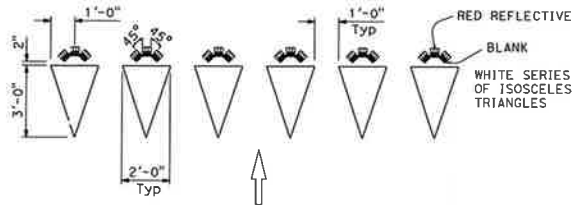

**YIELD LINE AT EXIT RAMP**

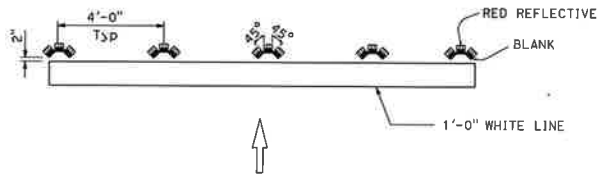

**LIMIT LINE (STOP LINE) AT EXIT RAMP**

**NOTE:**

1. If there is crosswalk at the end of the exit ramp, place Type R markers in front of the first line for wrong way vehicle that travels up the ramp with the red reflective side facing the intersection.

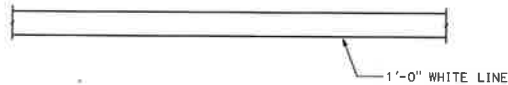

**LIMIT LINE (STOP LINE)**

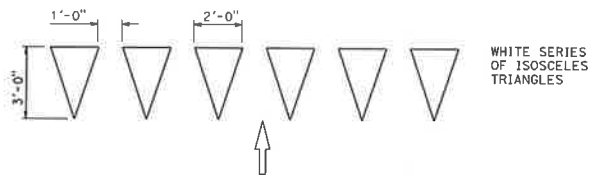

**YIELD LINE**

**LEGEND:**

- MARKERS**
- TYPE R ONE-WAY RED RETROREFLECTIVE

**MARKER DETAILS**

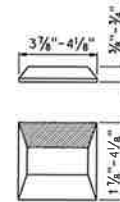

**TYPE R**

- RETROREFLECTIVE FACE ON BACKSIDE

STATE OF CALIFORNIA  
 DEPARTMENT OF TRANSPORTATION  
**PAVEMENT MARKINGS**  
**YIELD LINES, LIMIT LINES,**  
**AND WRONG WAY DETAILS**  
 NO SCALE

**A24G**

# **APPENDIX C**

## **STAGING AREA LOCATION AND LIMITS**





EL NIDO RANCH ROAD

MOUNT DIABLO BOULEVARD

STAGING AREA



RIGHT OF WAY

9 FEET BACK OF  
SIDEWALK TO R/W

43 FEET LIGHT  
POLE TO R/W

RIGHT OF WAY

98 FEET BACK OF SIDEWALK TO R/W AS A  
PROJECTION OF CROSSWALK LINE

RIGHT OF WAY

108 FEET BACK OF SIDEWALK TO R/W

# APPENDIX D

## QUANTITY SUMMARIES

Eliminate	DESCRIPTION	PAVEMENT REPAIR AND COATINGS				PAVEMENT MARKERS AND MARKINGS																				
		PAVEMENT REPAIR (3-INCH)	PAVEMENT REPAIR (6-INCH)	CRACK SEAL	Slurry Seal, Type II	REMOVE EXISTING PAVEMENT MARKERS AND THERMOPLASTIC STRIPES AND LEGENDS	"STOP" LEGEND THERMOPLASTIC	TYPE I ARROW THERMOPLASTIC	TYPE III ARROW THERMOPLASTIC	YIELD LINE	12" WHITE THERMOPLASTIC STRIPE	12" YELLOW THERMOPLASTIC STRIPE	DETAIL 6- DASHED CENTERLINE WITH REFLECTORS	DETAIL 21-CENTERLINE WITHOUT REFLECTORS	DETAIL 22- CENTERLINE WITH REFLECTORS	DETAIL 27B-FOG LINE	DETAIL 29 - DOUBLE YELLOW MEDIAN ISLAND	DETAIL 37 - LANE DROP AT EXIT RAMPS	DETAIL 38- CHANELIZING STRIPE WITH REFLECTORS	DETAIL 38A-CHANELIZING STRIPE WITHOUT REFLECTORS	DETAIL 38B- CHANELIZING STRIPE WITH REFLECTORS ON BOTH SIDES	DETAIL 39 - BIKE LANE SOLID LINE	DETAIL 39A - BIKE LANE DASHED LINE	DETAIL 40- CHANELIZING STRIPE WITH REFLECTORS ON BOTH SIDES	CURB PAINT	INSTALL "BLUE" TWO WAY PAVEMENT MARKERS
		SF	SF	Y/N	SY	Y/N	EA	EA	EA	LF	LF	LF	LF	LF	LF	LF	LF	LF	LF	LF	LF	LF	LF	LF	LF	LF
1	ACALANES ROAD VALENTE COURT TO EL NIDO RANCH ROAD	-	1,098	Y	12,774	Y	2	5	6	22	122	370	-	-	1,030	536	95	375	814	347	321	1,320	336	53	110	-
2	WEBB LANE MARIPOSA ST TO END	-	-	Y	618	Y	-	-	-	-	-	-	-	-	-	-	-	-	-	-	-	-	-	-	-	1
3	MOUNTAIN VIEW DRIVE MT. DIABLO TO BROOK ST	-	1,310	Y	3,896	Y	3	-	-	-	209	-	1,106	150	-	937	-	-	-	-	-	-	-	-	321	4
4	SIBERT COURT TANGLEWOOD DRIVE TO END	24	-	Y	696	N	-	-	-	-	-	-	-	-	-	-	-	-	-	-	-	-	-	-	-	-
5	TANGLEWOOD DRIVE MORAGA ROAD TO SIBERT COURT	126	-	Y	1,419	Y	1	-	-	-	-	-	-	50	-	110	-	-	-	-	-	-	-	-	-	1
6	SOLANA DRIVE ST. MARY'S ROAD TO HAMLIN ROAD	-	817	Y	4,085	Y	4	-	-	-	-	246	1,323	200	-	3,107	-	-	-	-	-	-	-	-	-	1
7	ST. MARY'S ROAD TOPPER LANE TO HOPE LANE	-	224	Y	1,872	Y	-	-	-	-	-	-	-	-	531	1,029	-	-	-	-	-	-	-	-	-	1
8	LAS HUERTAS ROAD ST. MARY'S TO OLD MILLSTONE LANE	1,030	-	Y	1,976	Y	1	-	-	-	-	-	-	50	-	217	-	-	-	-	-	-	-	-	-	1
9	HILLCREST DRIVE LAUREL DRIVE TO END	1,825	-	Y	1,990	N	-	-	-	-	-	-	-	-	-	-	-	-	-	-	-	-	-	-	-	
10	WILLOW DRIVE DYER ROAD TO MT DIABLO BLVD	218	-	Y	516	Y	1	-	-	-	-	-	-	50	-	217	-	-	-	-	-	-	-	-	-	-
<b>Total</b>		3,223	3,449	1	29,841	1	12	5	6	22	331	616	2,429	500	1,561	6,153	95	375	814	347	321	1,320	336	53	431	9



# **APPENDIX F**

## **RESIDENT NOTIFICATION LETTER**



City Council

Carl Anduri, Mayor  
Gina Dawson, Vice Mayor  
Susan Candell, Council Member  
Teresa Gerringer, Council Member  
Wei-Tai Kwok, Council Member

---

Dear Resident:

{Contractor}, under contract with the City of Lafayette, will be performing maintenance repairs on your street. This work will be done in one or three distinct phases, depending on the design treatment for your street. Please see work schedule on the back of this notice indicating what work is scheduled for your street. The hours of construction will be from 8:30 AM to 4:30 PM, Monday through Friday. Work will begin with pavement repairs followed by crack filling, and a slurry seal as a final finish. Please note that the slurry seal can take up to 3 hours to dry sufficiently to allow cars to drive on it.

In order to provide the City and its residents with a better looking and longer lasting road, as well as provide the workers with a safe work environment, we ask that traffic closures be observed. During the slurry seal process the following streets will be closed to all non-emergency vehicles (Webb Lane, Mountain View Drive, Sibert Court, Tanglewood Drive, Solana Drive, Las Huertas Road, Hillcrest Drive, Willow Drive). The remaining streets will be coated one side at a time. Access to properties will be restricted during this time as non-emergency vehicles will not be permitted to drive across or on the wet slurry. During the slurry seal process access to your property will not be possible for a period up to 5 hours. **Please note that if you live off a street that will receive a slurry seal treatment your access will also be restricted.**

Barricades and traffic cones will be placed to prevent vehicles from entering the wet areas. Please do not go around the traffic control devices; slurry seal is a tar-like substance that can splash onto the sides of vehicles as well as track onto other surfaces such as driveways and sidewalks if driven through or walked upon while wet. If you do have oil on something, simple dish soap and water will clean the area if caught before the oil has had time to dry. Otherwise we recommend a citrus solvent-type cleaner.

Notification and no parking signs will be placed on the road a minimum of 3 days prior to the start of each phase of work. These signs will provide the roadwork dates when parking on the street will not be allowed. It is very important that our contractor's crews have access to the entire street. Please note that vehicles parked on the street blocking construction activities will be towed at the owners' expense. In order to sweep excess loose rocks after placement, we request that you park off the chip-sealed streets for two days following the placement of the slurry seal.

**In the event the contractor is unable to perform slurry seal work on your street on the scheduled day project information signs at the entrance to your street will be updated to provide the new date and times for the work.**

If you have any questions regarding these access restrictions, please contact me at (925) 299-3245.

Sincerely,

Tim Clark  
Assistant Engineer

<b>Street and Limits of Work</b>	<b>Pavement Repair</b>	<b>Crack Fill</b>	<b>Slurry Seal</b>
<b>Acalanes Road</b> Valente Court to El Nido Ranch Road			
<b>Webb Lane</b> Mariposa Street to End			
<b>Mountain View Drive</b> Mt. Diablo Boulevard to Brook Street			
<b>Sibert Court</b> Tanglewood Drive to End			
<b>Tanglewood Drive</b> Moraga Road to Sibert Court			
<b>Solana Drive</b> St. Mary's Road to Hamlin Road			
<b>St. Mary's Road</b> Topper Lane to Hope Lane			
<b>Las Huertas Road</b> St. Mary's Road to Old Millstone Lane			
<b>Hillcrest Drive</b> Laurel Drive to End			
<b>Willow Drive</b> Dyer Road to Mt. Diablo Boulevard			

# **APPENDIX G**

## **PROJECT NOTIFICATION SIGNS**



**STREET MAINTENANCE PROJECT**

**PAVEMENT REPAIR**

**EXPECT TRAFFIC DELAYS**

**DATE: MONDAY, JUNE 15**

**HOURS: 8 AM – 5 PM**

**CONTRACTOR: (NAME)**

**Note:**

1. Notification signs shall be printed with a yellow background.
2. Signs shall be a minimum of 3 feet wide by 3 feet tall.



## **STREET MAINTENANCE PROJECT**

# **CRACK FILL**

# **EXPECT TRAFFIC DELAYS**

**DATE: MONDAY, JUNE 15**

**HOURS: 8 AM – 5 PM**

**CONTRACTOR: (NAME)**

**Note:**

1. Notification signs shall be printed with a yellow background.
2. Signs shall be a minimum of 3 feet wide by 3 feet tall.



## **STREET MAINTENANCE PROJECT**

# **SLURRY SEAL**

# **EXPECT TRAFFIC DELAYS**

**DATE: MONDAY, JUNE 15**

**HOURS: 8 AM – 5 PM**

**CONTRACTOR: (NAME)**

**Note:**

1. Notification signs shall be printed with a yellow background.
2. Signs shall be a minimum of 3 feet wide by 3 feet tall.



## **STREET MAINTENANCE PROJECT**

# **SLURRY SEAL**

# **ROAD CLOSURE**

**DATE: MONDAY, JUNE 15**

**HOURS: 8 AM – 5 PM**

**CONTRACTOR: (NAME)**

**Note:**

1. Notification signs shall be printed with a yellow background.
2. Signs shall be a minimum of 3 feet wide by 3 feet tall.





# UPDATE

**STREET MAINTENANCE PROJECT**

**SLURRY SEAL**

**ROAD CLOSURE**

**DATE: MONDAY, JUNE 15**

**HOURS: 8 AM – 5 PM**

**CONTRACTOR: (NAME)**

**Note:**

1. Re-notification signs shall be printed with a orange background.
2. Signs shall be a mimimum of 3 feet wide by 3 feet tall.