



VICTOR STANLEY, INC.

-Manufacturers of Quality Site Furnishings since 1962-

REV. 8/7/03 C.D.B.
Model: RB-28

SECTION 02870 SITE FURNISHINGS

PART 1 GENERAL

Model: RB-28

1.1 DESCRIPTION

- A. Section includes information, materials, and options for products manufactured by Victor Stanley, Inc. All specifications are subject to change. Contact manufacturer for details.

1.2 SUBMITTALS

- A. Specifications Drawing: Detail drawing of product including overall dimensions and options.
- B. Samples: Various component samples available upon request.
- C. Qualifications: Installer must submit evidence of a successful installation history with comparable materials and designs specified.

1.3 DELIVERY, STORAGE, and HANDLING

- A. Delivery: Deliver products to site in manufacturer's original, unopened containers and packaging. Upon delivery, examine packages immediately to ensure all products are complete and undamaged.
- B. Storage: Store products in a protected, dry area in manufacturer's unopened containers and packaging.
- C. Handling: Protect product's finish from damage during handling and installation.

1.4 COORDINATION

- A. Coordinate with site work and other appropriate sections of the specifications to maintain proper provisions of the work specified.
- B. All site furnishings shall be laid out in the field and approved prior to installation.

PART 2 PRODUCTS

2.1 MANUFACTURER

- A. Victor Stanley, Inc.
P.O. Drawer 330
Dunkirk, MD 20754 USA
Toll Free: (800) 368-2573 (USA & Canada)
Tel: (301) 855-8300 Fax: (410) 257-7579
E-mail: sales@victorstanley.com
Web site: <http://www.victorstanley.com>

2.2 BENCH

- A. Type: RB-28 from the Steelsites™ RB Series



2.3 MATERIALS

- A. Scrolled steel slats are formed from 1/4" x 1-1/2" (6.35mm x 38.1mm) solid steel bars; steel slats are welded to cross members of 1-5/16" (33.34mm) tubular steel; 3/8" x 1" (9.53mm x 25.4mm) solid steel support bars; 1/2" x 2" (12.7mm x 50.8mm) solid steel end units

2.4 OPTIONS

- A. Standard lengths: 4ft (1.2 meters), 6ft (1.8 meters), and 8ft (2.4 meters) (custom lengths available)
- B. Armrest(s)
- C. Matching full center leg(s)
- D. Standard colors: VS Bronze, VS Black, VS Green, VS Tavern Square Green, VS Teal, VS Blue, VS Burgundy, VS Red, VS White, VS Gray (custom colors available, including the RAL range, at a small additional cost)

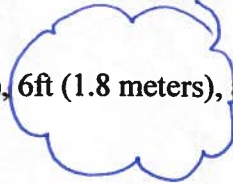

2.5 FINISHES

- A. All fabricated metal components are steel shotblasted, etched, phosphatized, preheated, and electrostatically powder-coated with TGIC polyester powder coatings. Products are fully cleaned and pretreated, preheated and coated while hot to fill crevices and build coating film. Coated parts are fully cured to coating manufacturer's specifications. The thickness of the resulting finish coat averages 8-10 mils (200-250 microns).
- B. In high salt abusive climates, hot dip galvanizing before powder coating is available. Hot dip galvanizing will provide greater protection in salty climates but yields a slightly less smooth coating finish. Most fabricated metal components and castings can be hot dip galvanized, lids cannot, please contact manufacturer for details.

Color
shall
be Black

PART 3 EXECUTION

3.1 INSTALLATION

- A. Clearance for 1/2" (12.7mm) anchor bolts (anchor bolts provided by others).
- B. Mounting: It is not recommended to locate anchor bolts until bench is in place. This Victor Stanley, Inc. product must be permanently affixed to the ground. Consult your local codes for regulations.

3.2 PROTECTION

- A. Protect products prior to installation by having them remain in the manufacturer's packaging and container.



VICTOR STANLEY, INC.®

-Manufacturers of Quality Site Furnishings since 1962-

P.O. DRAWER 330 - DUNKIRK, MD 20754 USA
TOLL FREE: (800) 368-2573 (USA & CANADA)
TEL (301) 855-8300 - FAX (410) 257-7579
WEB SITE: HTTP://WWW.VICTORSTANLEY.COM

* ALL DIMENSIONS ARE IN INCHES *

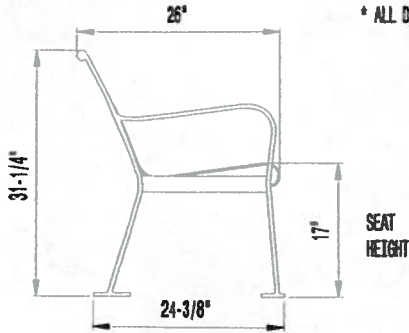

FRONT WELDS ARE POLISHED UNTIL THEY DISAPPEAR, FORMING A CONTINUOUS SURFACE

(27) STEEL SLATS ARE FORMED FROM 1/4" x 1-1/2" SOLID STEEL BARS

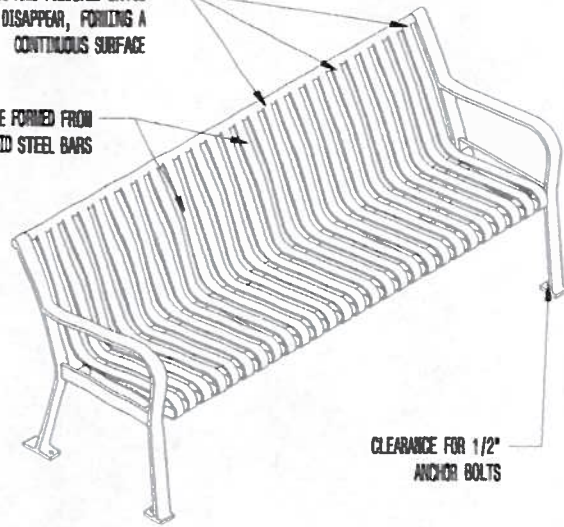

CLEARANCE FOR 1/2" ANCHOR BOLTS

FINISHED END UNIT IS MADE FROM 1/2" x 2" SOLID STEEL BAR

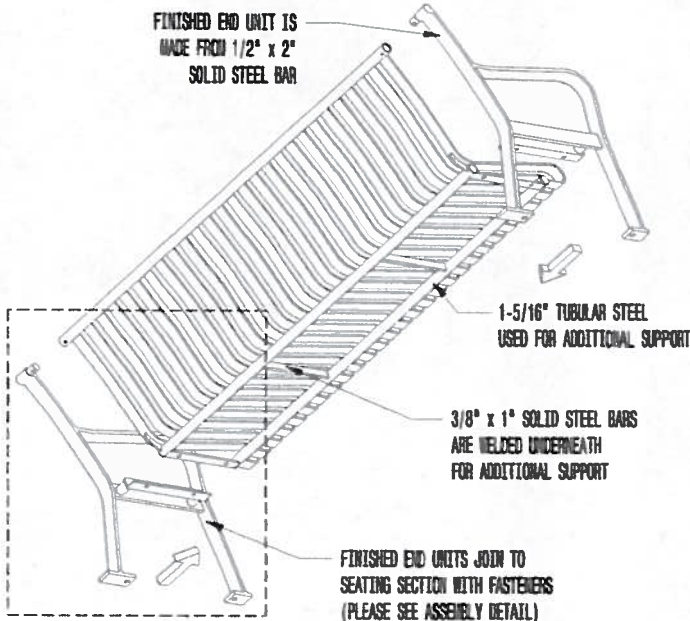

1-5/16" TUBULAR STEEL USED FOR ADDITIONAL SUPPORT

3/8" x 1" SOLID STEEL BARS ARE WELDED UNDERNEATH FOR ADDITIONAL SUPPORT

FINISHED END UNITS JOIN TO SEATING SECTION WITH FASTENERS (PLEASE SEE ASSEMBLY DETAIL)

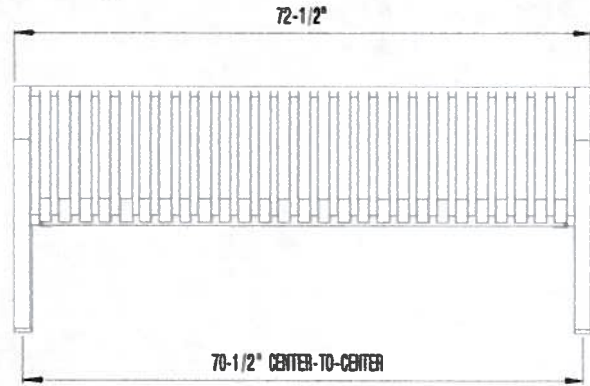

AVAILABLE OPTIONS

POWDER COATING

12 STANDARD COLORS, CUSTOM COLORS (INCLUDING THE RAL RANGE)
INTERMEDIATE & CENTER ARMRESTS
4', 6', & 8' AVAILABLE WITH OPTIONAL SOLID STEEL ARMRESTS

Color Black

LENGTHS

STANDARD 4'
STANDARD 6' LENGTH SHOWN
STANDARD 8'

NOTES:

1. DRAWINGS NOT TO SCALE. DO NOT SCALE DRAWINGS.
2. ALL FABRICATED METAL COMPONENTS ARE STEEL SHOTBLASTED, ETCHED, PHOSPHATIZED, PREHEATED, AND ELECTROSTATICALLY POWDER-COATED WITH T.G.T.C. POLYESTER POWDER COATINGS. PRODUCTS ARE FULLY CLEANED AND PRETREATED, PREHEATED AND COATED WHILE HOT TO FILL CREVICES AND BUILD COATING FILM. COATED PARTS ARE THEN FULLY CURED TO COATING MANUFACTURER'S SPECIFICATIONS. THE THICKNESS OF THE RESULTING FINISH AVERAGES 8-10 MILS (200-250 MICRONS).
3. IT IS NOT RECOMMENDED TO LOCATE ANCHOR BOLTS UNTIL BENCH IS IN PLACE. THIS VICTOR STANLEY, INC. PRODUCT MUST BE PERMANENTLY AFFIXED TO THE GROUND. CONSULT YOUR LOCAL CODES FOR REGULATIONS.
4. ANCHOR BOLTS NOT PROVIDED BY VICTOR STANLEY, INC.
5. FOR HIGH SALT ABUSIVE CLIMATES, HOT DIP GALVANIZING BEFORE POWDER COATING IS AVAILABLE. SEE WRITTEN SPECIFICATIONS FOR DETAILS.
6. ALL SPECIFICATIONS ARE SUBJECT TO CHANGE. CONTACT MANUFACTURER FOR DETAILS.
7. THIS PRODUCT IS SHIPPED PARTIALLY UNASSEMBLED.

ASSEMBLY DETAIL

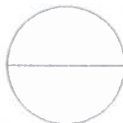
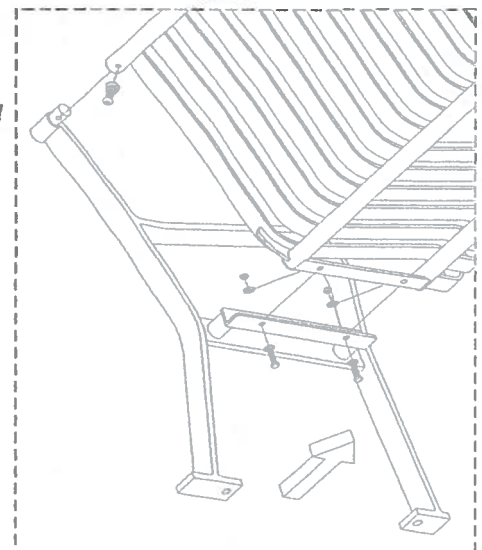

RB-28

STEELSPITS™ RB SERIES

ALL STEEL CONTOURED BENCH
SHOWN: STANDARD 6-FOOT LENGTH