

# **CITY OF LAFAYETTE**

3675 Mt. Diablo Boulevard, Suite 210  
(925) 284-1951  
[www.ci.lafayette.ca.us](http://www.ci.lafayette.ca.us)



## **NOTICE TO CONTRACTORS BID PROPOSAL CONTRACT AGREEMENT CONTRACT SPECIAL PROVISIONS**

**FOR**

## **CITY OF LAFAYETTE 2017 ROAD REHABILITATION PROJECT**

**Project No. 014-9711**

**Bid Opening Date  
Thursday, March 2, 2017, 2:30 p.m.**

## NOTICE TO CONTRACTORS

Sealed proposals will be accepted at the office of the City Clerk, 3675 Mt. Diablo Boulevard, Suite 210, Lafayette, California until 2:30 P.M., Thursday, March 2, 2017, at which time they will be publicly opened and read, for construction of **City of Lafayette, 2017 Road Rehabilitation Project, Project No. 014-9711**, including, but not limited to: mobilization; traffic control and construction signage; potholing utilities; clearing and grubbing including tree protection and trimming; removal and disposal of asphalt concrete pavement and subgrade, concrete and asphalt curb, gutter, flatwork; pulverizing, mixing, excavating, grading and compacting pavement subgrade and base materials; cement treatment of pulverized material; construction of minor concrete structures, concrete and/or asphalt curb, gutter, driveways, asphalt concrete pavement, storm drain facilities, traffic stripes, markers, and markings; adjustment of utility covers; installation of survey monuments; and all other miscellaneous work as shown on the Plans and as described in the Specifications to provide a complete project.

The Engineer's cost estimate is \$1,160,000.

The contract documents, including the Plans and Specifications may be obtained through the City of Lafayette Engineering Services Division by contacting the Engineering Assistant at [tkain@lovelafayette.org](mailto:tkain@lovelafayette.org) or (925)284-1951.

This project shall be constructed in accordance with the March 2013 edition of the City of Lafayette Standard Specifications, which may be obtained at the City of Lafayette Engineering Services Division. The cost of the Standard Specifications is \$20 per set; the cost of mailing is an additional \$8.

Bids shall be submitted in a sealed envelope titled "**Proposal: City of Lafayette, 2017 Road Rehabilitation Project, Project No. 014-9711**".

The Contractor shall possess a Class "A" license at the time this contract is awarded.

Bidder's attention is directed to requirements in Sections 2 and 3 of the Standard Specifications General Provisions. All bids shall be accompanied by a cashier's or certified check, or a bidder's bond executed by a corporate surety insurer. The bidder's guarantee shall be in the amount equal to at least ten (10) percent of the total bid and shall be made payable to the City of Lafayette. The successful bidder shall furnish a payment bond and a performance bond.

The City of Lafayette reserves the right to waive any informalities or to reject any or all bids. The City has ascertained the General Prevailing Rates of Wages applicable to this work, and these rates are on file at the City offices.

Time of completion allowed for this project will be 75 working days. Bidder's attention is directed to the order of work stated in Section 5 of the Special Provisions.

The plan holders list, as well as the City Standard Specifications, the Project Special Provisions and the General Prevailing Rates of Wages applicable to this work may be downloaded free of charge from the City of Lafayette web page at <http://www.ci.lafayette.ca.us> (click on *Public Works and Construction* under the Quick Links sidebar on the homepage, then *City Construction Projects*; **2017 Road Rehabilitation Project** is accessible under *Projects Bidding*). Or you may contact the Engineering Assistant at (925) 284-1951. Questions regarding the project Plans or Specifications may be directed to Matt Luttrupp, City Engineer's Office, (925) 299-3247.

CITY OF LAFAYETTE

Date:

1-25-17

By:

  
Tony Coe, City Engineer

TABLE OF CONTENTS

	<u>Page No.</u>
<b>NOTICE TO CONTRACTORS</b> .....	N-1
<b>BID PROPOSAL</b> .....	P-1
BID SCHEDULE .....	P-2
NONCOLLUSION DECLARATION .....	P-7
PROPOSAL GUARANTEE “BID BOND” WITH NOTORIZED SHEETS .....	P-8
PROPOSAL SIGNATURE SHEET .....	P-9
PUBLIC WORKS CONTRACTOR REGISTRATION CERTIFICATION .....	P-10
<b>CONTRACT AGREEMENT FOR CONSTRUCTION</b> .....	C-1
PAYMENT BOND .....	C-5
PERFORMANCE BOND .....	C-6
<b>SPECIAL PROVISIONS</b>	
SECTION SP-1 – GENERAL.....	S-1
SECTION SP-2 – NOT USED.....	S-1
SECTION SP-3 – NOT USED.....	S-1
SECTION SP-4 – PLANS AND SPECIFICATIONS (GENERAL) .....	S-2
SECTION SP-5 – CONTROL OF WORK AND MATERIALS .....	S-2
SECTION SP-6 – LEGAL RELATIONS AND RESPONSIBILITIES .....	S-5
SECTION SP-7 – UTILITY PROTECTION .....	S-7
SECTION SP-8 – PROGRESS OF WORK.....	S-7
SECTION SP-9 – NOT USED.....	S-9
SECTION SP-10– NOT USED .....	S-9
SECTION SP-11– NOT USED .....	S-9
SECTION SP-12– MOBILIZATION .....	S-9
SECTION SP-13– CONSTRUCTION AREA SIGNS.....	S-10
SECTION SP-14– TRAFFIC CONTROL, TEMPORARY PAVEMENT DELINEATION .....	S-10
SECTION SP-15– DUST CONTROL.....	S-12
SECTION SP-16– CLEARING AND GRUBBING, TREE TRIMMING AND PROTECTION.....	S-13
SECTION SP-17– EXISTING HIGHWAY FACILITIES.....	S-14
SECTION SP-18– FULL-DEPTH ASPHALT CONCRETE RECYCLING .....	S-20

SECTION SP-19– AGGREGATE BASE .....	S-21
SECTION SP-20– EXCAVATIONS .....	S-22
SECTION SP-21– NOT USED .....	S-23
SECTION SP-22– ASPHALT CONCRETE .....	S-23
SECTION SP-23– CONCRETE CONSTRUCTION.....	S-25
SECTION SP-24– STORM DRAINS .....	S-28
SECTION SP-25– PAVEMENT STRIPING, MARKERS AND DELINEATION .....	S-29
SECTION SP-26– SURVEY MONUMENT.....	S-30
SECTION SP-27– MISCELLANEOUS CONSTRUCTION.....	S-31
SECTION SP-28– TRAFFIC SIGN .....	S-33

**APPENDIX A: WASTE MANAGEMENT PLAN INSTRUCTIONS**

**APPENDIX B: STANDARD PLANS**

**APPENDIX C: ROAD CLOSURE SAMPLE LETTER AND SIGNS**

**APPENDIX D: EBMUD TEMPORARY CONSTRUCTION PERMIT,  
& CONTRACTORS POT HOLE LOG FORM**

**CITY OF LAFAYETTE  
CALIFORNIA**

**BID PROPOSAL**

**2017 ROAD REHABILITATION PROJECT**

**PROJECT NO. 014-9711**

TO THE CITY COUNCIL OF THE CITY OF LAFAYETTE:

In compliance with the annexed notice inviting sealed proposals, the undersigned bidder hereby proposes and agrees to perform the work therein described and to furnish all labor, materials and equipment necessary therefor, in accordance with the Plans and Specifications therefor, and further agrees to enter into a contract therefor, at the following prices:

<u>ITEM NO.</u>	<u>ITEM DESCRIPTION</u>	<u>ESTIMATED QUANTITY</u>	<u>UNIT</u>	<u>UNIT PRICE</u>	<u>TOTAL</u>
-----------------	-------------------------	---------------------------	-------------	-------------------	--------------

(SEE ATTACHED BID SCHEDULE)

- NOTES:
- All unit prices shall be considered the prices for providing a complete, in-place facility.
  - In the event of a discrepancy between the unit price and item total on the Bid Schedule, the unit price shall be used.

o o o

Bidder acknowledges the receipt of the following addenda to the drawings and specifications.

<u>Addendum No.</u>	<u>Date</u>	<u>Addendum No.</u>	<u>Date</u>
_____	_____	_____	_____
_____	_____	_____	_____

o o o

2017 ROAD REHABILITATION PROJECT  
PROJECT NO. 014-9711  
BID SCHEDULE

ITEM NO.	ITEM DESCRIPTION	ESTIMATED QUANTITY	UNIT	UNIT PRICE	TOTAL
1	Mobilization (SP-12)	1	LS		
2	Project Identification Signs (City Furnished) (SP-12)	5	EA		
3	Construction Area Signs (SP-13)	5	EA		
4	Traffic Control (SP-14)	1	LS		
5	Clearing and Grubbing, Tree Trimming, and Tree Protection (SP-16)	1	LS		
6	Lower Existing Manhole or Rodding Inlet Frame (SP-17)	26	EA		
7	Adjust Existing Manhole or Rodding Inlet Frame and Cover to Grade (SP-17)	26	EA		
8	NIC (SP-17)	-	EA		
9	Adjust Existing Utility Frame and Cover to Grade (SP-17)	23	EA		
10	Adjust Utility Box or Area Drain to Grade (SP-17)	3	EA		
11	Remove Storm Drain Pipe (Various Sizes) (SP-17)	130	LF		
12	Remove Asphalt Concrete Driveway, Pathway, Shoulder or Conform (SP-17)	6,943	SF		
13	Remove Paver Driveway or Pathway (SP-17)	109	SF		
14	Remove Concrete Curb and Gutter (SP-17)	2,212	LF		
15	Remove Concrete Driveway, Sidewalk, or Shoulder (SP-17)	379	SF		
16	Remove Concrete Valley Gutter (SP-17)	684	SF		
17	Remove Fence (SP-17)	120	LF		
18	Relocate Mailbox on New Post (SP-17)	1	EA		
19	Plug Drainage Inlet Side Opening (SP-23)	1	EA		
20	Concrete Curb (A1-6) (SP-23)	23	LF		
21	Concrete Curb and Gutter (SP-23)	2,212	LF		
22	Concrete Driveway (SP-23)	306	SF		
23	Concrete Sidewalk (SP-23)	47	SF		
24	Concrete Curb Ramp with Detectable Panel (SP-23)	190	SF		
25	Concrete Valley Gutter (SP-23)	642	SF		
26	Concrete Channel (SP-23)	1	EA		

2017 ROAD REHABILITATION PROJECT  
PROJECT NO. 014-9711  
BID SCHEDULE

ITEM NO.	ITEM DESCRIPTION	ESTIMATED QUANTITY	UNIT	UNIT PRICE	TOTAL
27	Install Type 'G' Inlet (SP-23)	2	EA		
28	Remove Type 'A' Inlet Top Install Type 'G' Inlet Top (SP-23)	3	EA		
29	Remove Type 'B' Inlet Top Install Type 'H' Inlet Top (SP-23)	1	EA		
30	Sheeting and Shoring (SP-24)	1	LS		
31	12" HDPE Pipe (SP-24)	71	LF		
32	Private Drain Line with Area Drain Extension (SP-24)	1	EA		
33	Flared End Section and Rock Headwall (SP-24)	-	EA		
34	Reset Brick Paver Surfacing (SP-27)	73	SF		
35	Remove and Reset Dry Stacked Rock Wall (SP-27)	56	LF		
36	Remove and Reset Brick Curb (SP-27)	23	LF		
37	Full-Depth Asphalt Concrete Recycling (SP-18)	6,950 (F)	CY		
38	Cement Treat Pulverized Base Material (SP-18)	3,610 (F)	CY		
39	Roadway Excavation (SP-20)	2,100 (F)	CY		
40	Asphalt Concrete Pavement (SP-22)	4,030	TONS		
41	AC Driveway, Pathway or Shoulder on Existing Base Material (SP-22)	2,571	SF		
42	AC Driveway, Pathway or Shoulder on 6" Class II AB (SP-22)	371	SF		
43	Type 'A' Asphalt Dike/Berm (SP-22)	377	LF		
44	Type 'C' Asphalt Dike/Berm (SP-22)	891	LF		
45	Temporary Pavement Delineation (SP-14)	1	LS		
46	Detail 21- Centerline (SP-25)	230	LF		
47	Detail 22 - Centerline (SP-25)	1,638	LF		
48	Detail 27B - 4" White Thermoplastic Edge Stripe (SP-25)	531	LF		
49	12-Inch Thermoplastic Stripe (SP-25)	81	LF		
50	Thermoplastic Pavement Legends and Markings (SP-25)	55	SF		
51	Two-Way Reflective Pavement Markers (Blue) (SP-25)	8	EA		
52	Install New Monument (SP-26)	20	EA		

2017 ROAD REHABILITATION PROJECT  
PROJECT NO. 014-9711  
BID SCHEDULE

ITEM NO.	ITEM DESCRIPTION	ESTIMATED QUANTITY	UNIT	UNIT PRICE	TOTAL
53	Shoulder Backing (SP-27)	1,590	LF		
54	Re-grade Earth Ditch (SP-27)	187	LF		
55	Relocate Traffic Sign on New Post (SP-28)	1	EA		
56	Remove Traffic Sign and Post (SP-28)	1	EA		
57	Install Traffic Sign and Post (SP-28)	1	EA		
	<b>TOTAL BASE BID</b>				

(F) Denotes Final Pay Quantity per Section 9-1.015 of the State Specifications



Bidder agrees that in case of default in executing and returning the required contract and bonds within ten (10) calendar days after having received the contract, proceeds of the guarantee accompanying his bid will become the property of the City of Lafayette.

o o o

In conformance with Subsection 2-13 "Listing of Proposed Subcontractors" of the Standard Specifications, the name and location of the place of business of each subcontractor is as follows:

	<u>NAME</u>	<u>DIR NUMBER</u>	<u>ADDRESS</u>	<u>WORK TO BE PERFORMED</u>
1.	_____	_____	_____	_____
2.	_____	_____	_____	_____
3.	_____	_____	_____	_____
4.	_____	_____	_____	_____
5.	_____	_____	_____	_____

o o o

Bidder certifies that he is licensed in accordance with an act providing for the registration of Contractors as follows:

License No. \_\_\_\_\_ Class \_\_\_\_\_

o o o

Bidder certifies that he has not, nor have any of his or its agents, officers, representatives, or employees, been guilty of collusion with any officer or representative of the City of Lafayette or with any other party or parties in the submission of this Proposal; nor has said bidder received any preferential treatment by any officer or employee of the City of Lafayette in the matter of making or submitting this proposal. The undersigned declares under penalty of perjury that the foregoing is true and correct.

o o o

Bidder certifies that there will be no discrimination in employment with regard to race, color, religion, sex, sexual orientation, or national origin; that all Federal, State, and local directives and executive orders regarding nondiscrimination in employment will be complied with and that the principle of equal opportunity in employment will be demonstrated positively and aggressively.

All bidders that have not had a contract with the City of Lafayette during the past three (3) years shall list below previous jobs that they have successfully completed and shall also show the amount of the contract

therefor.

Name and Address of Agency or Individual for Whom Work was Done	Phone Number	Date Completed	Contract Price
1.			
2.			
3.			
4.			
5.			
6.			

**NONCOLLUSION DECLARATION**

The undersigned declares:

I am the \_\_\_\_\_ of \_\_\_\_\_, the party making the foregoing bid.  
*Title Firm*

The bid is not made in the interest of, or on behalf of, any undisclosed person, partnership, company, association, organization, or corporation. The bid is genuine and not collusive or sham. The bidder has not directly or indirectly induced or solicited any other bidder to put in a false or sham bid. The bidder has not directly or indirectly colluded, conspired, connived, or agreed with any bidder or anyone else to put in a sham bid, or to refrain from bidding. The bidder has not in any manner, directly or indirectly, sought by agreement, communication, or conference with anyone to fix the bid price of the bidder or any other bidder, or to fix any overhead, profit, or cost element of the bid price, or of that of any other bidder. All statements contained in the bid are true. The bidder has not, directly or indirectly, submitted his or her bid price or any breakdown thereof, or the contents thereof, or divulged information or data relative thereto, to any corporation, partnership, company association, organization, bid depository, or to any member or agent thereof to effectuate a collusive or sham bid, and has not paid, and will not pay, any person or entity for such purpose.

Any person executing this declaration on behalf of a bidder that is a corporation, partnership, joint venture, limited liability company, limited liability partnership, or any other entity, hereby represents that he or she has full power to execute, and does execute, this declaration on behalf of the bidder.

I declare under penalty of perjury under the laws of the State of California that the foregoing is true and correct and that this declaration is executed on \_\_\_\_\_, at

\_\_\_\_\_  
*Date*  
\_\_\_\_\_, \_\_\_\_\_  
*City State*

By: \_\_\_\_\_  
*Signature*

Name: \_\_\_\_\_  
*Printed or Typed*

Date: \_\_\_\_\_

Title: \_\_\_\_\_

**PROPOSAL GUARANTEE**

**BID BOND**

**2017 ROAD REHABILITATION PROJECT**

**PROJECT NO. 014-9711**

KNOW ALL PERSONS BY THESE PRESENTS that \_\_\_\_\_, as BIDDER, and \_\_\_\_\_, as SURETY, are held and firmly bound unto City of Lafayette, as Owner, in the penal sum of \_\_\_\_\_ dollars (\$ \_\_\_\_\_) which is ten percent of the total amount bid by BIDDER to Owner for the above stated project, for the payment of which sum, BIDDER and SURETY agree to be bound, jointly and severally, firmly by these presents.

THE CONDITIONS OF THIS OBLIGATION ARE SUCH that, whereas BIDDER is about to submit a bid to Owner for the above stated project, if said bid is rejected, or if said bid is accepted and a contract is awarded and entered into by BIDDER in the manner and time specified, then this obligation shall be null and void, otherwise it shall remain in full force and effect in favor of Owner.

IN WITNESS WHEREOF the parties hereto have set their names, titles, hands, and seals this \_\_\_\_ day of \_\_\_\_\_, 2017.

BIDDER \_\_\_\_\_  
\_\_\_\_\_  
\_\_\_\_\_

SURETY \_\_\_\_\_  
\_\_\_\_\_  
\_\_\_\_\_

Subscribed and sworn to this \_\_\_\_ day of \_\_\_\_\_, 2017.

NOTARY PUBLIC \_\_\_\_\_

### PROPOSAL SIGNATURE SHEET

The completed proposal submitted herewith includes all sheets numbered "P-1 through P-10" at the bottom. The following required attachments have been executed and are included:

- a. Bid Proposal (with Addenda acknowledgement)
- b. Bid Schedule
- c. Noncollusion Declaration
- d. Proposal Guarantee "Bid Bond" with Notarized Signatures
- e. Proposal Signature Sheet
- f. Public Works Contractor Registration Certification

Legal Name of Firm: \_\_\_\_\_

Business Address: \_\_\_\_\_

Telephone Number: ( ) \_\_\_\_\_

Type of Organization: ( ) Individual ( ) Partnership ( ) Corporation

Joint Venture Proposal?: ( ) Yes ( ) No

Authorized Signature: \_\_\_\_\_

Name: \_\_\_\_\_

Position: \_\_\_\_\_

Date of Execution: \_\_\_\_\_

For a partnership, name all co-partners below,  
For a corporation, name president, secretary, treasurer and manager.

NAME	TITLE
_____	_____
_____	_____
_____	_____
_____	_____

Corporate Seal:

**PUBLIC WORKS CONTRACTOR REGISTRATION CERTIFICATION**

Pursuant to Labor Code sections 1725.5 and 1771.1, all contractors and subcontractors that wish to bid on, be listed in a bid proposal, or enter into a contract to perform public work must be registered with the Department of Industrial Relations. See <http://www.dir.ca.gov/Public-Works/PublicWorks.html> for additional information.

No bid will be accepted nor any contract entered into without proof of the contractor's and subcontractors' current registration with the Department of Industrial Relations to perform public work.

Contractor hereby certifies that it is aware of the registration requirements set forth in Labor Code sections 1725.5 and 1771.1 and is currently registered as a contractor with the Department of Industrial Relations.

Name of Contractor: \_\_\_\_\_

DIR Registration Number: \_\_\_\_\_

Contractor further acknowledges:

1. Contractor shall maintain a current DIR registration for the duration of the project.
2. Contractor shall include the requirements of Labor Code sections 1725.5 and 1771.1 in its contract with subcontractors and ensure that all subcontractors are registered at the time of bid opening and maintain registration status for the duration of the project.
3. Failure to submit this form or comply with any of the above requirements may result in a finding that the bid is non-responsive.

Signature: \_\_\_\_\_

Name and Title: \_\_\_\_\_

Dated: \_\_\_\_\_

**CITY OF LAFAYETTE**  
**CONTRACT AGREEMENT**  
**FOR**  
**CONSTRUCTION**

THIS AGREEMENT is made and entered into as of \_\_\_\_\_, 2017, by and between the CITY OF LAFAYETTE ("City") and \_\_\_\_\_ ("Contractor").

RECITALS

- A. City desires to retain the services of Contractor to provide services for Construction of **2017 Road Rehabilitation Project, Project No. 014-9711**, ("Project") including, but not limited to: mobilization; traffic control and construction signage; potholing utilities; clearing and grubbing including tree protection and trimming; removal and disposal of asphalt concrete pavement and subgrade, concrete and asphalt curb, gutter, flatwork; pulverizing, mixing, excavating, grading and compacting pavement subgrade and base materials; cement treatment of pulverized material; construction of minor concrete structures, concrete and/or asphalt curb, gutter, driveways, asphalt concrete pavement, storm drain facilities, traffic stripes, markers, and markings; adjustment of utility covers; installation of survey monuments; and all other miscellaneous work as shown on the Plans and as described in the Specifications to provide a complete project.
- B. Contractor has represented to City that it has the expertise, experience and qualifications to perform the services described in Paragraph A, above, and those services which are more fully described below.

NOW, THEREFORE, in consideration of the foregoing and the covenants and agreements set forth below, City and Contractor agree as follow:

- 1. Contract Documents. The contract documents for the aforesaid project shall consist of the Notice to Contractors, Bid Proposal, General Provisions, Technical Provisions, Special Provisions including appendices, Design Drawings, and all referenced specifications, details, standard drawings, and their appendices; together with this Contract Agreement and all required bonds, insurance certificates, permits, notices and affidavits; and also including any and all addenda or supplemental agreements clarifying, amending, or extending the work contemplated as may be required to insure its completion in an acceptable manner. All of the provisions of said contract documents are made a part hereof as though fully set forth herein.
- 2. Services. For and in consideration of the payments and agreements to be made and performed by City, Contractor agrees to furnish all materials and perform all work required for the above-stated project, and to fulfill all other obligations as set forth in the aforesaid contract documents. Contractor agrees to receive and accept the prices set forth in the Proposal as full compensation for furnishing all materials, performing all work, and fulfilling all obligations hereunder. Said compensation shall cover all expenses, losses, damages, and consequences arising out of the nature of the work during its progress or prior to its acceptance including those for well and faithfully completing the work and the whole thereof in the manner and time specified in the aforesaid contract documents; also including those arising from actions of the elements, unforeseen difficulties or obstructions encountered in the prosecution of the work, suspension or discontinuance of the work, and all other unknowns or risks of any description connected with the work.

3. Employment by City. City hereby promises and agrees to employ, and does hereby employ, Contractor to provide the materials, do the work, and fulfill the obligations according to the terms and conditions herein contained and referred to, for the prices aforesaid, and hereby contracts to pay the same at the time, in the manner, and upon the conditions set forth in the contract documents.
4. Worker's Compensation. Contractor acknowledges the provisions of the State Labor Code requiring every employer to be insured against liability for worker's compensation, or to undertake self-insurance in accordance with the provisions of that Code, and certifies compliance with such provisions. Limits shall be not less than those specified in the insurance requirements contained in the General Provisions of the Standard Specifications, and as modified in these Special Provisions.
5. Insurance. With respect to performance of work under this contract, Contractor shall maintain and shall require all of its subcontractors to maintain insurance as required in the General Provisions of the Standard Specifications, and as modified in these Special Provisions.
6. Indemnity. Contractor shall comply with the indemnification requirements contained in the General Provisions of the Standard Specifications.
7. Assignment. This contract is not assignable nor the performance of either party's duties delegable without the prior written consent of the other party. Any attempted or purported assignment or delegation of any of the rights or obligations of either party without the prior written consent of the other shall be void and of no force and effect.
8. Non-discrimination. Contractor shall not discriminate in the hiring of employees or the employment of subcontractors on any basis prohibited by law.
9. Independent Contractor. Contractor is and shall at all times remain as to City, a wholly independent contractor. Neither City nor any of its agents shall have control of the conduct of Contractor or any of the Contractor's employees, except as herein set forth. Contractor shall not at any time or in any manner represent that it or any of its agents or employees are in any manner agents or employees of City.
10. Contractor and Subcontractor Registration. Pursuant to Labor Code sections 1725.5 and 1771.1, all contractors and subcontractors that wish to bid on, be listed in a bid proposal, or enter into a contract to perform public works must be registered with the Department of Industrial Relations. No bid will be accepted nor any contract entered into without proof of the contractor's and subcontractors' current registration with the Department of Industrial Relations to perform public work. Contractor is directed to review, fill out and execute the Public Works Contractor Registration Certification contained in the Bid Proposal prior to contract execution.
11. Labor Compliance. This Project is subject to compliance monitoring and enforcement by the Department of Industrial Relations. It shall be the Contractor's sole responsibility to evaluate and pay the cost of complying with all labor compliance requirements under this Contract and applicable law.
12. Notices. All notices and communications shall be sent to the parties at the following addresses:

CITY:                   City Engineer  
                              City of Lafayette  
                              3675 Mount Diablo Boulevard, Suite 210  
                              Lafayette, California 94549



CONTRACTOR: \_\_\_\_\_  
\_\_\_\_\_  
\_\_\_\_\_  
\_\_\_\_\_

- 13. Authorized Signature. Contractor affirms that the signatures, titles, and seals set forth hereinafter in execution of this contract agreement represent all individuals, firm members, partners, joint ventures, and/or corporate officers having a principal interest herein.
- 14. Entire Agreement; Modification. This contract supersedes any and all other agreements either oral or written, between the parties and contains all of the covenants and agreements between the parties pertaining to the work of improvements described in Paragraph A of the Recitals herein above. Each party to this contract acknowledges that no representations, inducements, promises, or agreements, orally or otherwise, have been made by any party, or anyone acting on behalf of any party, which are not embodied herein, and that any other agreement, statements or promise not contained in this contract shall not be valid or binding. Any modification of this contract will be effective only if signed by the party to be charged.
- 15. Claims Procedure. In the event of a dispute between the parties regarding a) a time extension demand, b) payment arising for work performed by or on behalf of the contractor which is not otherwise expressly provided for, or c) an amount the payment of which is disputed by the City, the procedure in Section 10 of the City of Lafayette Standard Specifications shall be used.

IN WITNESS WHEREOF the parties hereto for themselves, their heirs, executors, administrators, successors, and assigns do hereby agree to the full performance of the covenants herein contained and have caused this Contract Agreement to be executed in duplicate by setting hereunto their names, titles, hands, and seals this \_\_\_\_ day of \_\_\_\_\_ 2017.

Contractor: \_\_\_\_\_  
<Type Business Name Here>

Name: \_\_\_\_\_

Title: \_\_\_\_\_

Contractor's License No. \_\_\_\_\_

Agency Business License No. \_\_\_\_\_

Federal Tax Identification No. \_\_\_\_\_

Subscribed and sworn to this \_\_\_\_ day of \_\_\_\_\_ 2017.

Notary Public \_\_\_\_\_

Agency: \_\_\_\_\_  
City Manager of the City of Lafayette

Attested: \_\_\_\_\_  
City Clerk of the City of Lafayette

Date: \_\_\_\_\_

**PAYMENT BOND**

**(TO BE EXECUTED WITHIN TEN [10] CALENDAR DAYS OF CONTRACT AWARD)**

WHEREAS, the City of Lafayette (Owner) has awarded to \_\_\_\_\_, as Contractor, a contract for the work described as follows: Construction of **2017 Road Rehabilitation Project, Project No. 014-9711**, including, but not limited to: mobilization; traffic control and construction signage; potholing utilities; clearing and grubbing including tree protection and trimming; removal and disposal of asphalt concrete pavement and subgrade, concrete and asphalt curb, gutter, flatwork; pulverizing, mixing, excavating, grading and compacting pavement subgrade and base materials; cement treatment of pulverized material; construction of minor concrete structures, concrete and/or asphalt curb, gutter, driveways, asphalt concrete pavement, storm drain facilities, traffic stripes, markers, and markings; adjustment of utility covers; installation of survey monuments; and all other miscellaneous work as shown on the Plans and as described in the Specifications to provide a complete project.

AND WHEREAS, said Contractor is required to furnish a bond in connection with said contract, to secure the payment of claims of laborers, mechanics, materials persons, and other persons as provided by law;

NOW, THEREFORE, we, the undersigned Contractor and surety, are held firmly bound unto the Owner in the sum of \_\_\_\_\_ Dollars (\$\_\_\_\_\_), for which payment well and truly to be made we bind ourselves, our heirs, executors and administrators, successors and assigns, jointly and severally, firmly by these presents.

THE CONDITION OF THIS OBLIGATION IS SUCH:

That if said Contractor, its heirs, executors, administrators, successors, or assigns, or subcontractors, shall fail to pay any of the persons named in Civil Code Section 3282, or amounts due under the Unemployment Insurance Code with respect to work or labor performed by any such claimant, or any amounts required to be deducted, withheld, and paid over to the Employment Development Department from the wages of employees of the Contractor and its subcontractors pursuant to Section 13020 of the Unemployment Insurance Code, with respect to such work and labor, that the surety or sureties herein will pay for the same in any amount not exceeding the sum specified in this bond, otherwise the above obligation shall be void. In case suit is brought upon this bond, the said surety will pay a reasonable attorney's fee to the Owner in an amount to be fixed by the court.

This bond shall insure to the benefit of any of the persons named in Civil Code Section 3181 as to give a right of action to such persons or their assigns in any suit brought upon this bond.

IN WITNESS WHEREOF, we have hereunto set our hands and seals on this \_\_\_\_ day of \_\_\_\_\_, 2017.

CONTRACTOR: _____	SURETY _____
Print Name: _____	NAME _____
Title: _____	ADDRESS _____
	TELEPHONE _____

**PERFORMANCE BOND**

**(TO BE EXECUTED WITHIN TEN [10] CALENDAR DAYS OF CONTRACT AWARD)**

KNOW ALL PERSONS BY THESE PRESENTS:

THAT WHEREAS, the City of Lafayette (Owner) has awarded to \_\_\_\_\_, as Contractor, a contract for the work described as follows: Construction of **2017 Road Rehabilitation Project, Project No. 014-9711**, including, but not limited to: mobilization; traffic control and construction signage; potholing utilities; clearing and grubbing including tree protection and trimming; removal and disposal of asphalt concrete pavement and subgrade, concrete and asphalt curb, gutter, flatwork; pulverizing, mixing, excavating, grading and compacting pavement subgrade and base materials; cement treatment of pulverized material; construction of minor concrete structures, concrete and/or asphalt curb, gutter, driveways, asphalt concrete pavement, storm drain facilities, traffic stripes, markers, and markings; adjustment of utility covers; installation of survey monuments; and all other miscellaneous work as shown on the Plans and as described in the Specifications to provide a complete project.

AS WHEREAS, the Contractor is required to furnish a bond in connection with said contract guaranteeing the faithful performance thereof;

NOW, THEREFORE, we, the undersigned Contractor and surety, are held firmly bound unto the Owner in the sum of \_\_\_\_\_ Dollars (\$ \_\_\_\_\_), to be paid to the Owner, its successors and assigns, for which payment well and truly to be made we bind ourselves, our heirs, executors and administrators, successors and assigns, jointly and severally, firmly by these presents.

THE CONDITION OF THIS OBLIGATION IS SUCH:

That if said Contractor, its heirs, executors, administrators, successors, or assigns, shall in all things stand to and abide by and well and truly keep and perform the covenants, conditions, and agreements in the foregoing contract and any alteration thereof made as therein provided on its or their part to be kept and performed at the time and in the manner therein specified and in all respects according to their true intent and meaning, and shall indemnify and save harmless the Owner, its officers, and agents, as therein stipulated, then this obligation shall become and be null and void; otherwise it shall be and remain in full force and effect. In case suit is brought upon this bond, the said surety will pay a reasonable attorney's fee to the Owner in an amount to be fixed by the court. Surety, for value received, hereby stipulates and agrees that no amendment, change, extension of time, alteration, or addition to said contract, and of any feature or item or items of performance required therein or thereunder, shall in any manner affect its obligations on or under this bond; and said surety does hereby waive notice of any such amendment, change, extension of time, alteration, or addition to said contract, and of any feature or item or items of performance required therein or thereunder, shall in any manner affect its obligations on or under this bond; and said surety does hereby waive notice of any such amendment, change extension of time, alteration, or addition to said contract, and of any feature or item or items of performance required therein or thereunder.

IN WITNESS WHEREOF, we have hereunto set our hands and seals on this \_\_\_\_ day of \_\_\_\_\_, 2017.

CONTRACTOR: _____	SURETY _____
Print Name: _____	NAME _____
Title: _____	ADDRESS _____
	TELEPHONE _____

**SPECIAL PROVISIONS SECTION SP-1**

**GENERAL**  
**(NO BID ITEM)**

**SP1-01 REFERENCES**

The work to be done under this contract, except as modified or supplemented herein, shall conform to the following:

- The City of Lafayette General Provisions of the Standard Specifications dated March 2013, herein referred to as the “General Provisions of the Standard Specifications”.
- The City of Lafayette Technical Provisions of the Standard Specifications dated March 2013, herein referred to as the “Technical Provisions of the Standard Specifications”.

Where specifically referred to, the work shall also conform to the following:

- The State of California Department of Transportation (Caltrans) Standard Specifications, For Construction of Local Streets and Roads, 2015 Edition, herein referred to as the “State Specifications” or “State Standard Specifications”.
- The State of California Department of Transportation (Caltrans) Standard Plans, 2015 Edition, herein referred to as the “State Standard Plans”.
- The Contra Costa County Public Works Department Standard Plans, most current edition, herein referred to as the “County Standard Plans”.

These Special Provisions are additions, modifications, or clarifications to the referenced Standard Specifications and generally supersede the referenced or applicable sections of said Standard Specifications. Refer to Section 5-4, “Precedence of Contract Documents”, of the General Provisions of the Standard Specifications for the order of precedence of Contract Documents. Where ambiguity or conflict exist in the interpretation of precedence, the provision resulting in the highest quality or most expensive grade of construction or product shall govern.

**SPECIAL PROVISIONS SECTION SP-2, 3 (NOT USED)**

**SPECIAL PROVISIONS SECTION SP-4**

**PLANS AND SPECIFICATIONS (GENERAL)**  
(NO BID ITEM)

The provisions of Section 4, "Plans and Specifications (General)," of the General Provisions of the Standard Specifications shall apply in their entirety and as supplemented herein.

**SP4-01 SCOPE OF WORK**

The work to be performed under this contract including, but not limited to: mobilization; traffic control and construction signage; potholing utilities; clearing and grubbing including tree protection and trimming; removal and disposal of asphalt concrete pavement and subgrade, concrete and asphalt curb, gutter, flatwork; pulverizing, mixing, excavating, grading and compacting pavement subgrade and base materials; cement treatment of pulverized material; construction of minor concrete structures, concrete and/or asphalt curb, gutter, driveways, asphalt concrete pavement, storm drain facilities, traffic stripes, markers, and markings; adjustment of utility covers; installation of survey monuments; and all other miscellaneous work as shown on the Plans and as described in the Specifications to provide a complete project.

**SP4-02 PAYMENT**

No separate payment will be made for preparing and submitting "As-Built Drawings." Full compensation for preparing and submitting "As-Built Drawings" shall be considered as included in the prices paid for various contract items of work, and no additional compensation shall be allowed therefor.

**SPECIAL PROVISIONS SECTION SP-5**

**CONTROL OF WORK AND MATERIALS**  
(NO BID ITEM)

The provisions of Section 5, "Control of Work and Materials," of the General Provisions of the Standard Specifications shall apply in their entirety and as supplemented herein.

**SP5-01 CONSTRUCTION SURVEY STAKING**

The Engineer will provide paint markings for pavement conforms, driveway paving conform limits, removal and replacement of pavement, curb, gutter, and driveways of all kinds.

The City shall provide all construction survey staking for alignment and grades of roadway, curb, gutter, storm drain, and other items which, in the opinion of the Engineer, require survey staking. The Contractor shall submit staking requests in writing at least five (5) working days in advance of beginning work that requires construction survey staking. The Contractor shall be responsible for paying the cost of resetting survey stakes which are damaged or obliterated by the Contractor's operations.

Survey stakes for roadway alignment and grade will be set on one side of the roadway only. These stakes will provide offset distances, and cuts or fills to the new crown or control line grade breaks, and where applicable, new curb and/or left and right edges of pavement.

The Contractor will be responsible for providing traffic control for the City's survey crew as necessary for any required offset stakes which will need to be set in the roadway, including providing a lane closure and/or flaggers when required. The Engineer will notify the Contractor a minimum of 48 hours prior to the required survey staking in order to coordinate traffic control.

#### **SP5-02 MATERIAL SAMPLING AND TESTING**

Compaction tests and/or material sampling and testing may be performed by the City's representatives on roadway subgrade, pulverized material, aggregate base, portland cement concrete, asphalt concrete, and other work and materials, which in the opinion of the Engineer, require sampling or testing. Test locations shall be determined by the Engineer. The Contractor shall coordinate and cooperate with the Engineer and testing personnel, and no claims of delays or inconvenience due to testing and/or sampling shall be allowed.

#### **SP5-03 SUBMITTALS**

At minimum, the Contractor shall provide submittals to the Engineer for the following materials. Additional submittals may be found in the various Special Provisions for the Work.

- Aggregate Base Class 2 (Material Source)
- Asphalt Concrete Mix Designs of All Types
- Portland Cement Concrete Mix Designs of All Types
- Cement Treatment of Subgrade
- Reinforcing Steel
- Storm Drain Inlet Grates and Covers
- HDPE Pipes
- Pavement Markers
- Thermoplastic Striping Material
- Sign and Post Materials
- Survey Monument Frames and Covers

- Water Pollution Control Plan
- Waste Management Plan
- Traffic Control Plan and Certification of Qualified Personnel
- CAL/OSHA Excavation Permit

#### **SP5-04 ORDER OF WORK**

Unless otherwise directed by the Engineer, the following major items of work shall be performed in the following general order. Not every item of Contract Work is shown. Contractor shall accordingly coordinate miscellaneous and coincidental work related to or associated with major work items in order to avoid out-of-sequence construction and conflicts. Not all stages of work apply to every location within the Project.

- 1) Notify Underground Service Alert (USA) to have utilities marked.
- 2) Apply for EBMUD temporary construction permit on Brookdale Court
- 3) Install construction area signs and project identification signs one week in advance of the start of work on a specific street or work area.
- 4) Install water pollution control measures.
- 5) Install tree protection.
- 6) Submit waste management plan prior to commencing any demolition work.
- 7) Perform utility potholing work to confirm depths of existing utility lines. No additional excavation work will be permitted until Contractor's Utility Pothole Log (Appendix D to Standard Specifications) is submitted to the Engineer.
- 8) Clearing, grubbing, and tree trimming.
- 9) Sawcut driveway conforms.
- 10) Remove, repair, modify, and/or construct storm drain facilities.
- 11) Remove, replace, and/or construct concrete curb, gutter, sidewalk, driveways, and other flatwork.
- 12) Reference and/or adjust survey monuments, all utility frames and covers to below grading plane.
- 13) Complete full-depth recycling, including cement treatment; finish grade and compact subgrade to design grades; and place asphalt concrete base course.
- 14) Sawcut and remove pavement at transverse conform joints at limits of paving.
- 15) Place asphalt concrete finish course. Place temporary roadway delineation.
- 16) Place asphalt concrete berms.
- 17) Pave driveway conforms and road shoulders
- 18) Raise/adjust all existing monument and utility frames and covers to final grade. Install new monuments.
- 19) Place permanent striping, markers and legends.



- 20) Complete all other construction work and punch list items.
- 21) Remove tree protection, construction area signs and project identification signs.
- 22) Submit completed waste assessment summary report form.
- 23) Submit as-built plans.

The Contractor's attention is directed to Section SP-8-02, "Progress Schedule", of these Special Provisions.

Any deviation from these requirements and provisions shall be sufficient cause for the Engineer to suspend the work in accordance with the provisions of Section 8-3, "Temporary Suspension of the Work", of the General Provisions. The contractor will not be permitted to resume the work until Contractor has remedied said deviation in accordance with the provisions of the Contract.

#### **SP5-05 PAYMENT**

No separate payment will be made for conforming to the provisions of this section. Full compensation for conforming to all the provisions of this section shall be considered as included in the prices paid for various contract items of work and no additional compensation will be allowed therefor.

### **SPECIAL PROVISIONS SECTION SP-6**

#### **LEGAL RELATIONS AND RESPONSIBILITIES**

(NO BID ITEM)

The provisions of Section 6, "Legal Relations and Responsibilities," of the General Provisions of the Standard Specifications shall apply in their entirety and as supplemented herein, and in other related sections of these Special Provisions.

#### **SP6-01 PUBLIC NOTIFICATIONS**

Notification requirements in Section 6-10, 6-12.3, and 6-13 of the Standard Specifications General Provisions shall apply. Notices for driveway closures must be issued each time a driveway access is restricted and must indicate the specific date and time of the anticipated restricted access.

#### **ROAD CLOSURE NOTIFICATIONS**

At least 7 calendar days prior to performing work that requires road closures, Contractor shall mail a written notice to all residents, emergency services, public transit operators, garbage and recycling collection agencies, the US Postal Service and, school bus services. The City will supply the

contractor with the text for the notices as well as a mailing list to be distributed (see [Appendix C](#) for sample text).

At least 7 calendar days prior to performing work that requires road closures, Contractor shall provide and install road closure notification signs at all exits from the limits of work. The signs shall be printed with black lettering on a yellow background and shall have text similar to the example signs found in [Appendix C](#) of these Special Provisions. The signs shall be a minimum of 3 feet wide by 3 feet tall and shall state the dates that the road will be closed. The signs may be printed on paper mounted to plywood. The contractor shall mount the signs to a Type III barricade. The Contractor shall submit a proof set for all notification signs to the Engineer for review and approval prior to manufacturing the signs.

If any road closure identified in the written notice to residents or subsequent road closure notification sign is not undertaken on the date(s) identified, Contractor shall install updated notification signs in-kind at least two days in advance of performing work on the street.

The Contractor shall maintain road closure notification signs in legible condition for the duration of their use.

#### **SP6-02 CORDINATION WITH WASTE/RECYCLING OPERATIONS**

The Contractor shall not impair or impede waste hauler and recycling operations scheduled to be conducted within the project area. It is the Contractor's responsibility to determine which waste haulers and recycling operators are scheduled to operate within the project area and to develop a project schedule that will not impair or impede the waste haulers or recycling operations. Contractor acknowledges that he is aware that various haulers and operators operate on different days on different streets within the project area.

#### **SP6-03 PERMITS AND LICENSES**

The Contractor shall fill out and submit the East Bay Municipal Utility District Temporary Construction Permit application in Appendix D. This permit only applies to the portion of Brookdale Drive that is within the EBMUD right of way.

#### **SP6-04 PAYMENT**

No separate payment will be made for conforming to the provisions of this section. Full compensation for conforming to all the provisions of this section shall be considered as included in the prices paid for various contract items of work and no additional compensation will be allowed therefor.

**SPECIAL PROVISIONS SECTION SP-7**

**UTILITY PROTECTION**

(NO BID ITEM)

The provisions of Section 7, "Existing Utilities," of the General Provisions of the Standard Specifications shall apply in their entirety and as supplemented herein.

**SP7-01 EBMUD AQUEDUCT**

The EBMUD aqueduct exists under Brookdale Court between approximately STA 9+00 and STA 12+00. Although the road reconstruction activities are not expected to impact the EBMUD aqueduct facilities, this portion of Brookdale Court is located in the EBMUD right-of-way and has been designated on the plans as a Special Construction Zone. The contractor shall be required to apply for a temporary construction permit from EBMUD for the work located in this zone. The permit application as well as a sample permit indicating conditions that may be required for this portion of the work is attached in Appendix D. Contractor shall expect the process to take at least 3 weeks from the time of application submittal.

All fees associated with the EBMUD Temporary Construction Permit shall be paid by the City of Lafayette by change order.

**SP7-02 PAYMENT**

No separate payment will be made for conforming to the provisions of this section. Full compensation for conforming to all the provisions of this section shall be considered as included in the prices paid for various contract items of work and no additional compensation will be allowed therefor.

**SPECIAL PROVISIONS SECTION SP-8**

**PROGRESS OF WORK**

(NO BID ITEM)

The provisions of Section 8, "Progress of Work," of the General Provisions of the Standard Specifications shall apply in their entirety and as supplemented herein.

**SP8-01 PRE-CONSTRUCTION MEETING**

A pre-construction meeting for this project will be held on Wednesday, March 22 at 2:00 p.m. at the City Offices. The Contractor shall submit all required bonds, insurance, and signed contracts prior to this meeting. The Notice to Proceed will be issued to the Contractor at the pre-

**construction meeting. Note: The prime contractor's full-time on-site superintendent or foreman for the project, along with any subcontractor that will be adjusting utility facilities (lowering and raising iron) are required to attend the preconstruction meeting.**

At the pre-construction meeting, representatives of the Owner, the Contractor, Subcontractors, and the Engineer will discuss in detail certain procedural aspects of the Work, including, but not limited to:

- Administrative procedures for transmittals, approvals, change orders, and similar items;
- Review of the method of application for payment, progress payments, retention; and final payment;
- Review of the Contractor's construction progress schedule;
- Clarifications of any questions regarding the contract Plans and Special Provisions;
- Review of traffic control procedures;
- At the preconstruction meeting the Contractor shall provide a Cal/OSHA trenching permit;

#### **SP8-02 PROGRESS SCHEDULE**

The Contractor shall submit the construction progress schedule to the Engineer at the pre-construction meeting. Contractor shall also submit an updated schedule by no later than Friday morning of each work week, and as requested by the Engineer per Section 8-2, "Progress Schedule," of the General Provisions of the Standard Specifications.

Attention is directed to Section SP5-04, "Order of Work," of these Special Provisions. Each schedule shall specifically note the timeframe and work to be performed by all subcontractors. Subcontractors shall receive all updated schedules so they can plan an appropriate work force to meet the prime Contractor's timeframe.

#### **SP8-03 WORKING HOURS**

Without prior written approval by the Engineer, and except for emergency work, work or activity of any kind shall be limited to the hours from 8:00 a.m. to 5:00 p.m. Monday through Friday. Contractor's attention is directed to hours for lane/road closures in Section SP-14 of these Special Provisions.

**SP8-04 TIME OF COMPLETION AND LIQUIDATED DAMAGES**

The Contractor shall complete the entire Work in this Contract within **seventy five (75)** working days from the start date, including completion of all “Punch List” work. Liquidated damages shall be assessed per Section 8-10, “Liquidated Damages,” the General Provisions of the Standard Specifications.

**The count of working days for this project will start no later than Monday, April 10, 2017.**

**SP8-05 PAYMENT**

No separate payment will be made for conforming to the provisions of this section. Full compensation for conforming to all the provisions of this section shall be considered as included in the prices paid for various contract items of work and no additional compensation will be allowed therefor.

**SPECIAL PROVISIONS SECTION SP-9, 10, 11 (NOT USED)**

**SPECIAL PROVISIONS SECTION SP-12**

**MOBILIZATION**

(BID ITEM NO. 1 AND 2)

The provisions of Section 1, “Mobilization,” of the Technical Provisions of the Standard Specifications shall apply in their entirety except as modified or supplemented herein.

**SP12-01 MEASUREMENT AND PAYMENT**

The lump sum Contract Price paid for “**Mobilization**” shall include full compensation for furnishing all labor, supervision, materials, tools, equipment and incidentals, and for all the work involved in mobilization of forces, equipment, materials, and meeting all general conditions and provisions of Contract Documents and as directed by the Engineer, and no additional compensation will be allowed therefor.

The Contract Price paid for each “**Project Identification Sign (City Furnished)**” shall include full compensation for furnishing all labor, supervision, materials, tools, equipment and incidentals, and for doing all the work involved in coordinating with the City to obtain the sign, transporting, installing signs on barricades, maintaining signs, removing signs and barricades, and returning signs to the City as specified in the Standard Specifications and these Special Provisions and as directed by the Engineer and no additional compensation will be allowed therefor.

**SPECIAL PROVISIONS SECTION SP-13**

**CONSTRUCTION AREA SIGNS**

(BID ITEM NO. 3)

**SP13-01 GENERAL**

The Engineer shall approve all locations prior to the Contractor installing signs. Signs shall be in place on the project site at least two (2) days prior to the start of work on each street, but not more than seven (7) days prior to the start of work on each street. Signs shall be removed within five (5) days of completing all work on each street. The Contractor shall notify the regional notification center for operators of subsurface installations (USA-Underground Service Alert: 1-800-227-2600), at least four (4) working days, but not more than fourteen (14) calendar days, prior to commencing any excavation for construction area sign posts.

The bottom of the mounted sign panel shall be seven (7) feet above existing grade.

**SP13-02 MEASUREMENTS AND PAYMENT**

Construction area signs shall be counted and paid based on the number of sign panels installed regardless of the number of sign posts installed.

The Contract Price paid per each for “**Construction Area Sign**” shall be considered as full compensation for furnishing all labor, supervision, materials, tools, equipment and incidentals, and for doing all work involved in furnishing, erecting, maintaining, and removing all construction area signs, as shown on the Plans, as specified in these Special Provisions, and as directed by the Engineer, and no additional compensation will be allowed therefor.

**SPECIAL PROVISIONS SECTION SP-14**

**TRAFFIC CONTROL**

(BID ITEM NO. 4)

**TEMPORARY PAVEMENT DELINEATION**

(BID ITEM NO. 45)

**SP14-01 GENERAL**

Work shall conform to the requirements of Section 6-12, “Traffic Control,” of the General Provisions and Section 15-4, “Removal of Existing and Temporary Traffic Stripes and Pavement Markings,” of the Technical Provisions of the Standard Specifications. Nothing in these Special Provisions shall be construed as relieving the Contractor from his/her responsibilities as specified in said sections. Any traffic striping or markings that are removed due to any phase of work shall be replaced, or re-aligned if required, with temporary traffic stripes or pavement markings. All temporary striping and

markings shall be placed the same day the permanent striping or markings are removed and they shall be placed before opening the roadway to public traffic.

#### **SP14-02 ROAD CLOSURE AND HOURS**

Contractor's attention is directed to noticing requirements in Section SP6-01.

Road closures shall only be permitted during the pavement pulverization, grading, cement treating, and paving phases of work. Road closure hours for those phases of work shall be allowed between 8:30 a.m. and 4:30 p.m. with the following exceptions:

Road closures shall not be permitted on Woodview Drive.

The Contractor may work under lane closure conditions in accordance to these Specifications before and after the allowable road closure dates and hours.

Contractor shall stage and sequence work such that road closures and disruptions to mobility of the public are minimized. Even under road closure conditions, Contractor shall make best efforts to allow passage of vehicles through the work zone when doing so does not interfere with active, critical work. This includes but is not limited to accommodating residents with medical, health, or safety-related needs (doctor appointments, emergency access, and access requirements due to physical disabilities). If work requiring closure is not actively in progress during allowed closure hours, the Engineer may order the road opened to public traffic. The Contractor shall coordinate road closures with garbage and recycling collection to ensure continuation of service during the construction period.

The full width of the traveled way shall be open for use by public traffic at all other times. Notwithstanding anything to the contrary, emergency vehicles shall be provided immediate access through the construction area at all times.

#### **SP14-03 FAILURE TO COMPLY**

Contractor's attention is directed to Standard Specifications General Provision Section 6-12.9 "Failure to Comply", which shall be augmented as follows.

If the Contractor fails to provide traffic control measures in conformance with the submitted traffic control plan, the Engineer may at his sole discretion issue a written warning to the Contractor. The warning shall indicate the location, date, and time of the failure to provide adequate traffic control. After the Second written warning, any violation of the traffic control provisions of the contract documents shall constitute grounds for the City to levy a penalty against the Contractor in the amount of \$500 per incident. Each hour of contract work activity occurring without traffic control as required by contract shall constitute a separate incident for the purpose of assessing the penalty. Contractor shall note that the above provisions are in addition to remedies and enforcement actions

specified in Section 6-12.9 referenced above. This penalty shall be deducted from any money due to the Contractor under the Contract.

#### **SP14-04 MEASUREMENT AND PAYMENT**

The contract lump sum price paid for **“Traffic Control”** shall be considered as full compensation for furnishing all labor, supervision, materials, tools, equipment and incidentals needed to perform all traffic control work, for all phases of the work performed by the Contractor or the Contractor’s “subcontractors” including, but not limited to, all signs, barricades, steel plates, traffic control plan, maintaining traffic, lane and road closures, flagmen and all other traffic control devices; and all other work as shown on Standard Plans, as specified in the Standard Specifications, the State Specifications, these Special Provisions, and as directed by the Engineer and no additional compensation shall be allowed therefor. There shall be no additional compensation for traffic control due to an increase in the quantities shown on the bid proposal for pay items within the project limits.

Traffic Control required by work which is classified as extra work, as provided in Section 9.3, “Extra Work”, of the General Provisions of the Standard Specifications, will be paid for as part of said extra work.

The contract lump sum price paid for **“Temporary Pavement Delineation”** shall include full compensation for furnishing all labor, supervision, materials, tools, equipment and incidentals and for doing all the work necessary to lay out, place, maintain, and remove temporary pavement striping, legends, arrows, glue down delineators, markers and markings, and all other work as shown on the Plans, as specified in these Special Provisions, and as directed by the Engineer, and no additional compensation shall be allowed therefor.

### **SPECIAL PROVISIONS SECTION SP-15**

#### **DUST CONTROL** (NO BID ITEM)

The provisions of Section 4, “Dust Control and Watering”, of the Technical Provisions of the Standard Specifications shall apply in their entirety and as supplemented herein.

#### **SP15-01 GENERAL**

On streets receiving pulverization and cement treatment, Contractor shall keep the pulverized or cement-treated street moist to control dust, using a water truck or other similar equipment. The street surface shall be moistened a minimum of four times each day (including weekends), and more often as needed to control the dust. If the road becomes too wet, and vehicles track material onto adjacent surfaces, or the wet condition poses a hazard to drivers, the Contractor shall modify his dust control method accordingly to remedy the situation.



**SP15-02 PAYMENT**

No separate payment shall be made for conforming to the provisions of this section. Full compensation for conforming to all the provisions of this section shall be considered as included in the prices paid for various contract items of work and no additional compensation shall be allowed therefor.

**SPECIAL PROVISIONS SECTION SP-16**

**CLEARING AND GRUBBING, TREE TRIMMING AND PROTECTION**

(BID ITEM NO. 5)

The provisions of Section 2, "Clearing and Grubbing," Section 21, "Tree Trimming and Removal," and Section 22-3, "Tree and Plant Protection," of the Technical Provisions of the Standard Specifications shall apply in their entirety except as modified or supplemented herein.

**SP16-01 GENERAL**

In addition to requirements of the Standard Specifications, clearing and grubbing work shall also include removing and/or relocating landscape borders, decorative rocks, and similar decorative features that conflict with planned construction. Where they occur, Contractor shall salvage these features by placing removed items in a neat stack at an adjacent location on the property frontage to be designated by the Engineer.

All cleared and grubbed areas shall be approved by the Engineer before further grading commences.

**SP16-02 MEASUREMENT AND PAYMENT**

The contract lump sum price paid for "**Clearing & Grubbing, Tree Trimming, and Tree Protection**" shall include full compensation for furnishing all labor, supervision, materials, tools, equipment and incidentals, and for doing all the work involved in implementing tree protection measures, clearing and grubbing, and tree trimming, and all other work as shown on the Plans, as specified in the Standard Specifications, these Special Provisions, and as directed by the Engineer, and no additional compensation shall be allowed therefor

## **SPECIAL PROVISIONS SECTION SP-17**

### **EXISTING HIGHWAY FACILITIES**

(BID ITEM NO. 6-18)

#### **SP17-01 GENERAL**

Work shall consist of removing, abandoning, relocating, or protecting existing facilities which interfere with construction. Work performed in connection with various existing highway facilities shall conform to applicable provisions of Section 7, "Existing Utilities," of the General Provisions, Section 2, "Clearing and Grubbing," and Section 22, "Protection and Restoration of Existing Improvements," of the Technical Provisions of the Standard Specifications, these Special Provisions, and as directed by the Engineer.

The Contractor shall fully document pre-construction conditions at all points around the work area. This documentation shall consist of notes, still photographs, and video. Special effort shall be made to document the existing conditions at all buildings and private improvements not to be disturbed. These documents shall be available to the City upon request.

If Contractor damages or destroys materials or facilities designated on the Plans, in these Special Provisions, or by the Engineer to be protected, salvaged or reused, he shall repair or replace them in kind at his sole expense.

#### **SP17-02 REMOVALS**

Contractor's attention is directed to Section 6-11, "General Safety," of the Standard Specifications General Provisions, and Section SP-27, "Temporary Pavement Delineation," of these Special Provisions.

Removals of existing road facilities not considered to be included in other Contract Work include—concrete, paver, or asphalt concrete driveway, pathway, sidewalk, shoulder, and other flatwork; concrete curb and gutter; storm drain pipes, structures, ditches, and channels. All other removals as shown on the drawings and as directed by the Engineer to accommodate new construction as intended by Contract, for which no specific Bid Item is shown, shall be considered as incidental work.

Where existing curb and gutter is to be removed and replaced, and the adjacent pavement is intended to remain, removal work shall include the removal of said curb and gutter and a sufficient area of the adjacent pavement to a proper depth to allow the forming and construction of the replacement new curb and gutter.

For removals that involve sawcutting, all sawcut lines shall be approved by the Engineer prior to sawcutting. Sawcutting of gutter lips shall be to a neat, straight line in alignment with the projected

gutter lip line of adjacent sections. Removal of obstructions in gutters shall be done with care so as to avoid damaging the underlying gutter to remain.

Removals of area in preparation for new construction shall extend to a depth that is sufficient to accommodate the new improvements to be constructed, including any necessary subgrade. Otherwise, removal shall extend to a depth at least six inches below the surface of the final condition required by Contract.

Storm drain facilities adjoining those designated to be removed shall be protected. Except where Contract Work requires a replacement facility, or otherwise directed by the Engineer, openings leading to/from the facility to be removed shall be plugged per Section 2-5 of the Technical Provisions of the Standard Specifications.

Where existing facilities such as pavers, flagstones, fencing, and miscellaneous property frontage improvements are required to be removed temporarily to provide clearance for construction, upon completion of said construction they shall be reset to their original location and alignment, in a condition equal to or better than that pre-existing.

The Engineer may direct Contractor to salvage components of private improvements designated to be removed. In such cases, Contractor shall take care to remove the components in a manner to reasonably minimize damage and stockpile them neatly in a location designated by the Engineer.

### **SP17-03 MONUMENTS AND PROPERTY CORNERS**

All monuments and property corners are to be preserved unless designated on the plans to be replaced. The Contractor shall bear the expense of replacing and recording with the County any monument or benchmark that is disturbed and was not designated to be replaced. Replacement shall be done only under the direction of and in the presence of the Engineer or a licensed surveyor.

### **SP17-04 REMOVE AND RELOCATE MAILBOX**

Existing mailboxes shall be removed and reset on a new redwood post, or existing post if the owner of the mailbox prefers to salvage and re-use a painted or decorative post. Mailbox removal locations shall be as shown on the Plans or any location that an existing mailbox interferes with contract work. The exact relocation shall be designated by the Engineer or mail carrier. Mailboxes shall be removed reset during the same work day. The new installation shall be in accordance with Contra Costa County Detail CA90i, "Mailbox Details," or matching the existing condition (post, footing, mailbox, size, color), whichever is of a higher quality or more expensive construction in current dollars. To coordinate with other construction, Contractor may set a mailbox in a temporary condition acceptable to the Engineer and the mail carrier.

All excavation resulting from removals shall be backfilled with Class II aggregate base and compacted to 90% relative compaction.

**SP17-05 LOWERING AND RAISING MANHOLE COVERS AND RODDING INLETS**

Work involves storm drain, sanitary sewer, gas and similar utility manhole covers and sanitary sewer rodding inlets. Work consists of initially lowering these facilities to accommodate construction and subsequently raising them to finished grade in conformance with Section 22-9 of the Technical Provisions of the Standard Specifications.

Before excavating the existing roadway, manhole structures and rodding inlets located within repaving limits shall be lowered to a point below the final roadway planing, pulverizing, or excavation depth. If a manhole or rodding inlet condition does not allow said lowering, then the facility shall be lowered as much as practically possible using all reasonable means. Contractor shall then coordinate his construction equipment, means, and methods to avoid damage to the facility during construction.

Adjustments below the planing, pulverizing, or excavation depth shall include but not be limited to placement of temporary false bottoms in manholes, removal of existing concrete collars, cutting riser pipes, salvaging the existing frames and covers, removal of riser rings, placing and securing in place an acceptable temporary steel cover below the required depth, and placement of temporary asphalt concrete over and around the temporary cover to allow safe passage of vehicular traffic prior to and following roadway excavation. Each false bottom shall be constructed of two pieces of standard-grade plywood, or similar material, that is hinged together so that they can be folded in half to fit through the manhole opening. The false bottom shall be set securely near the bottom of the manhole structure above the sewer flowline, in a manner so as to ensure that flow in the manhole is not impeded by debris entering the manhole inadvertently. Any debris that does enter the manhole or inlet shall be immediately removed. For rodding inlets, the adjustment shall include placing a temporary plug in the riser pipe and covering the pipe with a temporary steel lid. The plug shall be a mechanical type plug. Inflatable plugs shall not be allowed.

Manholes and rodding inlets located within new paving limits shall be raised to finished grades per Section 22-9.2 and Section 22-9.3 of the Standard Specifications, Technical Provisions, following the placement of the final lift of asphalt concrete. For all rodding inlets, the maximum distance between the finished pavement grade and the top of the riser pipe shall be six (6) inches. If the distance to the top of the riser pipe is greater than six (6) inches, the riser shall be extended with a new section of pipe connected with a mechanical fitting that produces a smooth interior with no offset or obstruction. The adjusted sanitary sewer manholes and rodding inlets shall conform to all utility company standards and requirements.

Frames and covers for sanitary sewer manholes may be re-used if they are in good condition and if the manhole covers have a nominal diameter dimension of twenty-five inches (25"). Existing frames and covers that exceed this dimension shall be replaced. In this case, the Central Contra Costa Sanitary District shall provide new frames and covers to be installed by Contractor. At its discretion CCCSD may also elect to provide new sewer rodding inlet frames and covers to be installed by Contractor. Contractor shall coordinate the delivery and integration of materials to be furnished by CCCSD with the District representative.

CCCSD at its sole discretion may elect to adjust its own facilities. In that case, the quantities shown on the Bid Schedule shall be adjusted accordingly, and Contractor shall comply with Section 22-9.3 of the Standard Specifications Special Provisions.

#### **SP17-06 ADJUSTING EXISTING UTILITY FRAMES AND COVERS TO GRADE**

Work shall consist of protecting the existing utility frames, covers and riser pipe in place and shall include all work necessary to work around the existing facilities during all phases of work. Where noted on the plans, EBMUD will lower the indicated frame, cover, and riser pipe below the pulverizing, or excavation depth. Contractor shall request the adjustment by EBMUD a minimum of two weeks in advance of the start of road reconstruction work on these streets. Contractor shall adjust all frames, covers and riser pipes to finished grade in conformance with Section 22-9 of the Technical Provisions of the Standard Specifications. Contractor shall note that the adjustment may be lower or higher than the existing pavement grade. Extension of a riser pipe shall be made using material similar to the existing, and the two pipes shall be mechanically connected to provide a smooth interior with no offset or obstruction.

Water valves shall be adjusted to grade using a new "G5" box as shown in the detail in Appendix A. The G5 boxes will be provided by the East Bay Municipal Utility District (EBMUD) free of charge. Contractor shall coordinate the delivery or pick-up and integration of materials to be furnished by EBMUD with District representatives. All other frames and covers, shall be adjusted reusing the existing riser and cover with a concrete collar and that is topped with asphalt concrete per the detail in Appendix B.

**The Contractor shall phase his work so that all water valves that are lowered remain so for a maximum of 20 calendar days prior to being raised to finished grades. In the event that Contractor fails to adjust said valves to grade and make them fully accessible within twenty (20) calendar days from the initial lowering, Contractor expressly agrees to defend, indemnify, and hold harmless City of Lafayette, EBMUD and their Directors, officers, agents, and employees from and against any and all loss, liability, expense, claims, suits, and damages, including attorneys' fees, arising out of or resulting from the inability to operate said valves.**

EBMUD at its sole discretion may elect to adjust its own facilities. In that case, the quantities shown on the Bid Schedule shall be adjusted accordingly, and Contractor shall comply with Section 22-9.3 of the Standard Specifications Technical Provisions.

#### **SP17-07 UTILITY BOX ADJUSTMENTS**

Where utility boxes are encountered within the limits of the planned work, Contractor shall adjust utility boxes to the new finished grade. Said adjustment shall include relocation of boxes to a new location as necessary to accommodate new construction. Relocation shall require Contractor to modify and extend the associated existing plumbing to the new location.

For water meters, Contractor shall coordinate with EBMUD to obtain new utility boxes and integrate them into the Work. All boxes shall be placed securely in place on a compacted base in native material, asphalt concrete, or concrete as applicable, in a manner that would not result in settling over time. The boxes shall be set so that they are accessible by utility personnel.

EBMUD at its sole discretion may elect to adjust its own facilities. In that case, the quantities shown on the Bid Schedule shall be adjusted accordingly, and Contractor shall comply with Section 22-9.3 of the Standard Specifications Special Provisions.

#### **SP17-08 NOT USED**

#### **SP17-09 MEASUREMENT AND PAYMENT**

No separate payment shall be made for conforming to the provisions of this section, with the exception of the items specified below. Full compensation for conforming to all the provisions of this section, including minor removal work and the resetting of temporary removals, for which no specific payment is allowed in Contract, shall be considered to be incidental work included in prices paid for various other contract items of work, and no additional compensation will be allowed therefor.

The contract unit prices paid per each for **“Lower Existing Manhole or Rodding Inlet Frame”** shall include full compensation for furnishing all labor, supervision, materials, tools, equipment and incidentals necessary to lower the frames and covers; including, but not limited to- locating, referencing, and setting marks; lowering the facility; placement of “false bottoms”; cleaning out the structure or riser; placement of temporary cover; placement of temporary asphalt concrete; maintain temporary asphalt concrete; and all other work as specified in these Special Provisions, and as directed by the Engineer, and no additional compensation will be allowed therefor. Contract quantities may be reduced or eliminated based on work to be performed by others. No adjustment in the bid item price shall be allowed due to any change in contract quantities.

The contract unit prices paid per each for **“Adjust Existing Manhole or Rodding Inlet Frame and Cover to Grade”** and **“Adjust Existing Utility Frame and Cover to Grade”** shall include full compensation for furnishing all labor, supervision, materials, tools, equipment and incidentals necessary to raise the frames and covers, including but not limited to- locating, referencing, and setting marks; all coordination work; raising the facility to finished grade; placement of concrete collars and temporary and permanent asphalt concrete; and all other work as shown on the Plans, as specified in these Special Provisions, and as directed by the Engineer, and no additional compensation will be allowed therefor. Contract quantities may be reduced or eliminated based on work to be performed by others. No adjustment in the bid item price shall be allowed due to any change in contract quantities.

The contract unit prices paid per each for **“Adjust Utility Box or Area Drain to Grade”** include full compensation for furnishing all labor, materials, tools, equipment and incidentals, and for doing all the work involved in adjusting the facilities to grade complete in place, including all required

excavation, backfilling, compaction, placing of temporary asphalt concrete, and permanent restoration to match surrounding materials, and all other work as shown on the plans and/or applicable standard plans, and as specified in the Standard Specifications and these Special Provisions, and as directed by the Engineer, and no additional compensation will be allowed therefor. Contract quantities may be reduced or eliminated based on work to be performed by others. No adjustment in the bid item price shall be allowed due to any change in contract quantities.

The Contract Price paid per each for **“Relocate Mailbox on New Post”** and per linear foot for **“Remove Fence”** shall include full compensation for furnishing all labor, supervision, materials, tools, equipment and incidentals necessary to perform the demolition, removal, disposal or salvaging as directed, remove and reset mailboxes, including, but not limited to all excavation and backfill, temporary installations, new mailbox posts and concrete footings, and all other work as specified in these Special Provisions, and as directed by the Engineer, and no additional compensation shall be allowed therefor.

The Contract Prices paid per square foot for **“Remove Concrete Driveway, Sidewalk or Shoulder,”** **“Remove Paver Driveway or Pathway,”** **“Remove Asphalt Concrete Driveway, Pathway, Shoulder or Conform,”** and **“Remove Concrete Valley Gutter”** shall include full compensation for furnishing all labor, materials, tools, equipment and incidentals necessary to sawcut, remove, dispose of and/or salvage existing improvements, and all excavation and preparation required to accommodate new improvements as shown on the contract plans, as specified in these Special Provisions, and as directed by the Engineer, and no additional compensation shall be allowed therefor.

The Contract Prices paid per linear foot for **“Remove Concrete Curb and Gutter”** shall include full compensation for furnishing all labor, materials, tools, equipment and incidentals necessary to remove and dispose of existing concrete curb and gutter, adjacent asphalt pavement or other paving as necessary to accommodate form boards, and all excavation and backfill as required to accommodate new improvements as shown on the contract plans, as specified in these Special Provisions, and as directed by the Engineer, and no additional compensation shall be allowed therefor. Contract quantities may be reduced or eliminated based on work to be performed by others. No adjustment in the bid item price shall be allowed due to any change in contract quantities.

The Contract Prices paid per linear foot for **“Remove Storm Drain Pipe (Various Sizes)”** shall include full compensation for furnishing all labor, materials, tools, equipment, and incidentals necessary to excavate, sawcut, remove, and dispose of the existing facilities, including shoring and backfill where required, and all other work as noted on the plans, as specified by these Special Provisions, and as directed by the Engineer, and no additional compensation shall be allowed therefor.

**SPECIAL PROVISIONS SECTION SP-18****FULL-DEPTH ASPHALT CONCRETE RECYCLING**

(BID ITEM NO. 37-38)

The provisions of Section 11, "Full-Depth Asphalt Concrete Recycling," of the Technical Provisions of the Standard Specifications shall apply in their entirety except as modified or supplemented herein.

**SP18-01 GENERAL**

**Pulverizing and mixing shall be performed using a pulverizing machine. A grinding machine shall not be acceptable.**

Per Section SP-7, "Existing Utilities," of these Special Provisions, Contractor shall pothole to confirm all utilities are below the designed street pulverization depth, and that utilities will not be damaged while pulverizing and mixing the existing asphalt concrete, base and subgrade material. Contractor shall take precautions to protect manholes, valves, and similar facilities that were not lowered or that have been lowered to the lowest grade possible but are still within the designed pulverizing depth. Contractor shall pulverize and mix or remove the pavement and base materials to the full pulverization depth around and or over these facilities to the fullest extent possible, using non-mechanical means as necessary.

Contractor's attention is directed to SP-20-02, "Roadway Excavation," regarding the removal of excess pulverized materials prior to grading and compaction of new subgrade.

All streets designed to receive cement treatment shall be treated within three (3) working days of the pulverizing being completed. The asphalt concrete base course shall be installed within three (3) working days after the minimum 48-hour cure time of the cement treatment. Each day after the total eight-working-day period described above, failure to complete the base course per these Special Provisions shall constitute a violation subject to a penalty of \$250 per violation per street. Said penalty assessment shall be deducted from any payments due to Contractor. In addition, the Engineer may require the implementation of additional dust control measures as outlined in Section SP15 "Dust Control" of these Special Provisions.

**SP18-02 MEASUREMENT AND PAYMENT**

The final pay Contract Price paid per cubic yard for "Full-Depth Asphalt Concrete Recycling" shall include full compensation for furnishing all labor, supervision, materials, tools, equipment and incidentals, and for doing all the work, including, but not limited to- potholing; pulverizing; asphalt dike removal within the pulverizing limits; mixing; moisture conditioning; grading; and compacting pulverized material; constructing, maintaining, removing, and disposing of temporary ramps; dust



control; and all other work as shown on the Plans, as specified in these Special Provisions, and as directed by the Engineer, and no additional compensation shall be allowed therefor. Cement treatment is measured and paid separately as follows.

The final pay Contract Price paid per cubic yard for **“Cement Treat Pulverized Base Material”** shall include full compensation for furnishing all labor, supervision, materials, tools, equipment and incidentals for doing all work involved including but not limited to- furnishing, spreading and mixing cement and water; grading; excavation; shaping; compaction; trimming; curing; monitoring and maintenance over weekends and holidays; dust control; proof-rolling; and all other work as shown on the Plans, as specified in these Special Provisions, and as directed by the Engineer, and no additional compensation shall be allowed therefor.

Payment for excavating, loading, offhauling and disposal of unstable material shall be paid as extra work at the contract item price per cubic yard for “Roadway Excavation,” and shall conform to the provisions of Section SP-20, “Excavations,” of these Special Provisions. Payment for backfilling unstable areas with asphalt concrete as base repairs shall be paid at the contract item price per ton for “Asphalt Concrete Pavement,” and shall conform to the provisions of Section SP-22, “Asphalt Concrete,” of these Special Provisions.

The quantities shown for “Full-Depth Asphalt Concrete Recycling” and “Cement Treat Pulverized Base Material” on the Bid Schedule shall be “Final Pay” quantities in accordance with the provisions of Section 9-6 of the General Provisions or the Standard Specifications.

## **SPECIAL PROVISIONS SECTION SP-19**

### **AGGREGATE BASE** (NO BID ITEM)

The provisions of Section 8, “Aggregate Base”, of the Technical Provisions of the Standard Specifications shall apply in their entirety except as modified or supplemented herein.

For certain installations, in lieu of Class II aggregate base, Contractor may be allowed to use pulverized material with maximum-size aggregates less than two (2) inches, generated from Project Work. The pulverized material shall be free of organic and other deleterious debris. The Engineer shall determine whether the material is suitable as a substitution based on inspection. The Engineer’s decision shall be at his sole discretion, shall be final, and shall not constitute a contract change.

### **SP19-01 MEASUREMENT AND PAYMENT**

There shall be no separate measurement or payment for furnishing and placing the aggregate base used in the construction of the various items of work shown on the Plans, bid proposal, and specified herein, and full compensation shall be considered as included in the contract unit prices paid for those bid items requiring aggregate base, and no additional compensation shall be allowed therefor.

## **SPECIAL PROVISIONS SECTION SP-20**

### **EXCAVATIONS** (BID ITEM NO. 39)

#### **SP20-01 GENERAL**

Excavation of all kinds shall conform to Section 3, "Earthwork," of the Standard Specifications Technical Provisions.

Pavement cores were obtained to determine the existing pavement section thickness and subgrade material. The cores for this project do not reveal any concrete in the areas to be excavated. The coring locations and material information is shown on the Contract Plans.

Contractor's attention is directed to Section 6-5, "Weight Limitation," of the General Provisions of the Standard Specifications.

#### **SP20-02 ROADWAY EXCAVATION**

Work shall include the excavation and disposal of pulverized materials determined by the Contractor to be excess, as part of the Full-Depth Asphalt Concrete Recycling process. Said excavation and disposal shall be to achieve the structural section as shown on the plans and in these Special Provisions. All material not suitable or used as road subgrade, shoulder backing, or backfill shall be considered excess. The excess material shall be removed with a grinding (or milling) machine conveying material directly into hauling trucks, which immediately off-haul the material from the work-site. Disposal shall be in accordance with the provisions of Section 6-16, "Disposal Outside Project Limits," of the General Provisions of the Standard Specifications.

Excess pulverized/mixed material will consist of asphalt concrete, base material and native material, and may contain reinforcing fabric and/or other particles that are a by-product of asphalt concrete. The City makes no guarantee that the material will be reusable or recyclable. No additional compensation shall be allowed to the Contractor if the pulverized material is deemed not reusable or recyclable. Any testing, if required, by the disposal site shall be arranged and paid for by the Contractor.

**SP20-03 MEASUREMENT AND PAYMENT**

Unless otherwise provided by a Contract Bid Item, there is no separate measurement or payment for excavation associated with various Contract Work, such as curb and gutter, walkway, driveways, storm drains, and minor structures. All excavation and backfill necessary to construct all Contract Work shall be considered as included in the Contract Prices paid for the various items of work.

The final pay Contract Price per cubic yard for “**Roadway Excavation**” shall include full compensation for all labor, materials, tools, equipment and incidentals, and all work involved, to remove, load, handle, off-haul, and dispose of materials as shown on the Plans, as specified in these Special Provisions, and as directed by the Engineer, and no additional compensation shall be allowed therefor.

The quantities shown for “Roadway Excavation” on the Bid Schedule shall be a “Final Pay Quantity” in accordance with the provisions of Section 9-6 of the General Provisions of the Standard Specifications.

**SPECIAL PROVISIONS SECTION SP-21 (NOT USED)****SPECIAL PROVISIONS SECTION SP-22****ASPHALT CONCRETE**

(BID ITEM NO. 40-44)

The provisions of Section 9, “Asphalt Concrete”, of the Technical Provisions of the Standard Specifications shall apply in its entirety except as modified or supplemented herein. Failed pavement area repair shall conform to Section 5, “Street Failed Area Repair,” of said Technical Provisions.

**SP22-01 DRIVEWAYS, PATHWAYS, AND SHOULDER CONFORM PAVING**

Asphalt driveway, pathway and shoulder conform limits are approximate. The Engineer will delineate actual conform lines prior to the start of work. Substrate conditions for conform paving differ depending on the project location as shown on the Plans. Conform paving may be installed on existing pavement, on existing base, or on new subbase. In all cases, a paint binder (tack coat) conforming to Standard Specification Technical Provision Section 9-11 shall be required. When conform paving is installed on unpaved base materials, the minimum thickness of finish asphalt concrete paving is three (3) inches.

Where asphalt concrete thickness is required to be three (3) inches minimum, Contractor may install asphalt concrete in multiple lifts to a total thickness greater than three (3) inches to meet the design or conform grades. At Contractor’s option, suitable backfill materials may be used to prepare the subgrade such that the finish asphalt concrete paving meets the three (3) inch minimum. Suitable backfill may be Class II Aggregate Base conforming to SP-19 or pulverized material, having maximum-

size aggregates less than two (2) inches, generated from Contract Work and determined to be suitable by the Engineer.

Where a new subbase is required per the Contract Plans, the subgrade shall be excavated and compacted to the required depth to accommodate the design structural section. New subbase shall be six (6) inches minimum, consisting of Class II aggregate base conforming to SP-19 and compacted to 95% relative compaction.

All conforms shown adjacent to a berm of any type shall be paved at the same time as the berm placement and shall be compacted with a vibraplate, small roller, or similar compactor, at the time of placement.

### **SP22-02 ASPHALT BERM (DIKE)**

Berms, or dikes, shall be in accordance with applicable details shown on State Standard Plans. Berm locations include those shown on the Plans.

Prior to placement of the berm, the underlying pavement shall be thoroughly cleaned and a tack coat per Standard Specifications Technical Provisions Section 9-11 shall be applied to the pavement surface. The berm shall be placed and compacted utilizing a self-propelled mechanical extruding machine capable of achieving the lines and grades shown on the Plans and the finished dimensions for the specified type of berm. The Contractor shall protect newly-placed berm to allow sufficient time for curing. Berms that slough, fall apart, or otherwise become damaged before curing shall be completely removed and replaced at the Contractor's expense. If a section of berm looks "patched," it shall be entirely removed and replaced with a conforming berm that is smooth and uniform in appearance.

Berms shall be reduced to 2-inches in height at driveways. The top of the berm at driveways shall be compacted with a vibraplate, or similar compactor, at the time of placement. Driveway and shoulder conforms adjacent to any asphalt concrete berms shall be placed and compacted at the same time as the berms to achieve a monolithic construction.

The ends of new berms shall be painted white with two coats of traffic paint for a minimum length of one foot, and a Type "C" pavement marker shall be placed on top of the berm where it tapers to end.

Private drain lines terminating near the edge of the existing road shall be extended through the face of new Type 'A' asphalt berm using 3" diameter schedule 40 PVC pipe. Contract Work for the installation of new asphalt berms shall include extending said drain lines to the new face of berm and integrating them into the new construction.

All berms shall be backed with either asphalt concrete conform paving, select fill, pulverized material, aggregate base, topsoil, gravel, or other material that matches the existing surrounding shoulder material.

**SP22-03 MEASUREMENT AND PAYMENT**

The contract unit price paid per ton for **“Asphalt Concrete Pavement”** shall be considered as full compensation for furnishing all labor, supervision, materials, tools, equipment and incidentals to complete the necessary work, including but not limited to- cleaning existing pavement; furnishing, transporting, placing, spreading and compacting asphalt concrete; tack coat binder; constructing, maintaining, removing, and disposing of temporary asphalt concrete ramps; all roadway conform paving; any necessary corrective measures; and all other work as shown on the Plans, as specified in these Special Provisions, and as directed by the Engineer, and no additional compensation shall be allowed therefor.

The contract unit prices paid per square foot for **“AC Driveway, Pathway, or Shoulder on Existing Base Material”** and **“AC Driveway, Pathway or Shoulder on 6” Class II AB”** shall include full compensation for furnishing all labor, supervision, materials, tools, equipment and incidentals and for doing all work involved including but not limited to- excavation required to install required structural section; subgrade preparation; cleaning; tack coat; furnishing, placing, spreading, and compacting the asphalt concrete to the specified depth; and all other work as shown on the Plans, as specified in these Special Provisions, and as directed by the Engineer, and no additional compensation shall be allowed therefor.

The contract unit prices paid per linear foot for **“Asphalt Berm”** of various types shall include full compensation for furnishing all labor, supervision, materials, tools, equipment and incidentals necessary to construct the asphalt concrete dike including but not limited to- cleaning; tack coat binder; placing, compacting, protecting and backfilling berms; white traffic paint and Type “C” markers on Type ‘A’ berm ends; incidental extension of private drain pipes to be incorporated into the berm construction; and all other work as shown on the Plans, as specified in these Special Provisions, and as directed by the Engineer, and no additional compensation shall be allowed therefor. Note that in certain constructions the payment of backfill of berms may be included in other items of work elsewhere in the Contract.

**SPECIAL PROVISIONS SECTION SP-23****CONCRETE CONSTRUCTION**

(BID ITEM NO. 19-29)

The provisions of Section 17, “Concrete Construction,” of the Technical Provisions of the Standard Specifications shall apply in their entirety except as modified or supplemented herein. Section 17-7 of said Technical Provisions shall also apply to construction of storm drain inlets.

**SP23-01 GENERAL**

All new curb, gutter, driveways, and storm drain structures shall conform to the latest applicable Contra Costa County (CCC) Public Works Department “Standard Plans” unless otherwise specified or modified by Contract Documents. All new concrete construction shall include installation of a

subbase consisting of a minimum six (6)-inch-thick layer of Class 2 aggregate base, conforming to SP-19, compacted to 95% relative compaction. Work also includes constructing dowelled connections between new and existing facilities.

All new inlet tops shall have a City-furnished sticker, stating “No Dumping – Drains to Creek.” affixed to the curb or other logical nearby location.

All new storm drain connections to new or existing storm drain inlets or manholes shall include a weep hole to drain the pipe backfill. Weep holes shall only be required where new storm drains enter the structure.

All new storm drain inlets shall have one 4” PVC schedule 40 pipe stubbed into the structure for future private drain connections. Pipe shall extend a minimum of 6 inches beyond the outside wall of the structure and as directed by the engineer. Pipe shall be capped with a PVC cap.

The void between the back of new concrete curbs, inlets, and driveways and the surrounding terrain shall be filled with material to match existing surrounding material. This material is typically topsoil, gravel or base rock. Fill material shall be placed and compacted to the top of the new concrete improvements and sloped at a maximum of 3:1 to conform to the existing terrain. The fill material shall be compacted to 90% relative compaction. In areas where topsoil is placed, a 1-inch layer of mulch shall be placed over the topsoil.

### **SP23-02 CONCRETE REQUIREMENTS**

Concrete used for all items on this project shall be Class 564-C-3250 with minimum 28-day compressive strength of 3,250 pounds per square inch. The maximum slump shall be four (4) inches.

Slurry backfill for trenches shall conform to Section 19-3.02G, “Controlled Low-Strength Material,” of the State Specifications. Material shall have a minimum compressive strength of 100 pounds per square inch.

### **SP23-03 MINOR CONCRETE CONSTRUCTION**

Curb and gutter shall match existing curb and gutter configuration except that 6 inches of base rock shall be placed under new curb and gutter.

Where existing curb is of colored concrete contractor shall make every effort to match the existing color.

Where curb drains exist in curb and gutter to be removed and replaced, Contract Work for the replacement new curb and gutter shall include extending said drain lines to the new face of curb and integrating them into the new construction conforming to the details shown on the Plans or various Standard Plans.

In modifying inlet tops, Contractor shall remove existing tops of inlets in any manner that protects the base of the inlets and their connections to storm drain pipes. Precautions shall be taken to avoid introducing debris into the storm drain system. New inlet tops shall be cast in place and dowelled into the existing inlet base per details on the Plans. Dowels shall have a maximum spacing of 6 inches.

Dowels used in connections between new and existing facilities shall be #4 rebars, 12" long. The dowels shall be in drilled holes, grouted and spaced in conformance with the details shown on CCC Standard Plan CA74i and these Special Provisions. All dowels shall have a minimum 1 ½" concrete cover.

Contractor's attention is directed to the potential existence of private irrigation facilities located behind the existing curb and gutter or at drain inlet locations. Coordination, protection, and relocation of these facilities are considered incidental to Contract Work per Section 7 of the Standard Specifications General Provisions. Contractor shall repair any damage on the same day that it is caused by his activities, to a fully functional condition.

#### **SP23-04 PATH OF TRAVEL TACTILE SURFACES**

The color of detectable tactile warning panels shall be onyx black (Federal Color No. 17038). Contractor shall submit a six (6)-inch square sample of the product to be used, along with the manufacturer's product data and "cut-sheets" for review and approval prior to ordering. The detectable warning surface shall conform to:

1. Americans with Disabilities Act (ADA) Title III Regulations, 28 CFR Part 36 "ADA Standards For Accessible Design," Appendix A, Section 4.29 for "Detectable Warnings."
2. Division of the State Architect - Access Compliance (DSA-AC) approved detectable warning products as provided in the California Code of Regulations (CCR) Title 24, Part 2, Section 205 definition of "Detectable Warning."

City may accept products from ADA solutions (800-372-0519), Answer Industries (909-230-4064), and Armor-Tile (916-844-4132).

#### **SP23-05 CONFORM PAVING**

Unless otherwise specifically provided elsewhere in these Special Provisions, conform paving adjacent to new concrete construction, such as curb, gutter, inlets and associated aprons, and valley gutter shall be considered to be included in the Contract Work to construct those items. Asphalt concrete for conform paving shall conform to SP-22.

**SP23-06 MEASUREMENT AND PAYMENT**

The Contract Price paid per linear foot for **“Concrete Curb and Gutter,” “Concrete Curb (A1-6),”** per square foot for **“Concrete Driveway,” “Concrete Sidewalk,” “Concrete Valley Gutter,”** and **“Concrete Curb Ramp with Detectable Panel”** and per each for **“Concrete Channel”** shall include full compensation for furnishing all labor, supervision, materials, tools, equipment and incidentals necessary to complete the work, including but not limited to- sawcutting; excavation and preparing subbase; dewatering; loading, hauling, and disposal of spoils; forming, placing, and finishing concrete; backfill; conform paving; doweled connections; setting tactile surfaces in accordance with manufacturer’s instructions, and all other work necessary to construct the facility complete and in place as shown on the plans, as specified in these Special Provisions, and as directed by the Engineer, and no additional compensation shall be allowed therefor.

The Contract Price paid per each for the **retrofit and installation of various drainage structures (inlets and manholes)** shall include full compensation for furnishing all labor, supervision, materials, tools, equipment and incidentals for doing all work involved, including but not limited to- sawcutting; removals where needed; excavation and preparing subbase; dewatering; loading, hauling, and disposal of spoils; forming, placing, and finishing concrete; installing frames and grates; backfill; doweled connections; and all other work necessary to construct the facility complete and in place as shown on the plans, as specified in these Special Provisions, and as directed by the Engineer, and no additional compensation shall be allowed therefor.

“Concrete Curb Ramp with Detectable Panel” shall be measured as the ramp area up to the outer most groove line defining the ramp, up to and including the adjacent retaining curb where it exists, and inclusive of the detectable panel. The retaining curb associated with a curb ramp shall not be paid separately as a curb item.

Concrete inlet aprons, regardless of size, are measured and paid per linear foot as “Concrete Curb and Gutter.”

**SPECIAL PROVISIONS SECTION SP-24****STORM DRAINS**

(BID ITEM NO. 30-33)

The provisions of Section 18, “Storm Drains”, of the Technical Provisions of the Standard Specifications shall apply in their entirety except as modified or supplemented herein.

**SP24-01 MEASUREMENT AND PAYMENT**

The Contract Prices paid per linear foot for **installation of various pipe classes** shall be considered as



**SP24-02 MEASUREMENT AND PAYMENT**

The Contract Prices paid per linear foot for **installation of various pipe classes** shall be considered as full compensation for furnishing all labor, supervision, materials, tools, equipment and incidentals necessary to perform all work, including but not limited to- potholing; sawcutting; excavation; installing various pipes with fittings and flared end section; bedding and backfill; compaction; temporary asphalt concrete paving; coordination with, protecting, and supporting existing utilities; and all other work as shown on the Plans, as specified in the Standard Specifications, these Special Provisions, and as directed by the Engineer; and no additional compensation shall be allowed therefor.

The contract price paid per each for **“Flared End Section and Rock Headwall”** shall include full compensation for furnishing all labor, supervision, materials, tools, equipment and incidentals for doing all the work involved in placing and constructing the flared end section and rock headwall, including but not limited to all excavation and backfill, and all other work as specified in these Special Provisions, and as directed by the Engineer, and no additional compensation shall be allowed therefor.

The contract lump sum price paid for **“Sheeting and Shoring”** shall include full compensation for furnishing all labor, supervision, materials, tools, equipment and incidentals for doing all the work involved in sheeting and shoring as specified in the Standard Specifications; as required by the California Occupational Safety and Health Administration, the California Division of Industrial Safety, and all applicable laws; and these Special Provisions; and as directed by the Engineer; and no additional compensation shall be allowed therefor.

**SPECIAL PROVISIONS SECTION SP-25****PAVEMENT STRIPING, MARKERS AND DELINEATION**

(BID ITEM NO. 46-51)

The provisions of Section 15, “Pavement Striping, Markers, and Delineation”, of the Technical Specifications of the Standard Specifications shall apply in their entirety except as modified or supplemented herein.

**SP25-01 GENERAL**

Contractor’s attention is directed to notification requirements in Section 15-2 of the Standard Specifications Technical Provisions. No payment shall be made for any striping work performed without notification to the City conforming to the above.

During pavement striping and marking operations, the Contractor shall implement traffic control as specified in SP-14 of these Special Provisions.

### **SP25-02 MEASUREMENT AND PAYMENT**

Traffic stripes shall be measured by the linear foot along the line of the traffic stripe without deductions for the gaps, shown on the standard details. Deductions will be made for gaps at cross streets and driveways.

Measurement for legends and markings shall be per the areas shown on State Standard Plans.

The Contract Prices paid per linear foot for **various stripes and striping details**, per square foot for **“Thermoplastic Pavement Legends & Markings,”** and per each for **“Two-Way Reflective Pavement Markers (Blue),”** shall include full compensation for furnishing all labor, materials, tools, equipment, and incidentals, including any necessary cat tracks, dribble lines and layout work; and all other work as shown on the Plans, the State Standard Plans, and as specified in these Special Provisions, and as directed by the Engineer, and no additional compensation shall be allowed therefor.

## **SPECIAL PROVISIONS SECTION SP-26**

### **SURVEY MONUMENT**

(BID ITEM NO. 52)

### **SP26-01 GENERAL**

Contractor shall remove and dispose of existing monuments where shown on the plans or as directed by the Engineer. New survey monuments shall be set at locations shown on the Plans or as designated by the Engineer in the field in accordance with the details shown on County Standard Plan CC105, “Street Survey Monument.” Frames, covers, collars, concrete cores and brass markers shall be furnished and installed by the Contractor. The City will set reference points, prior to the start of construction, for existing survey points.

At least five (5) working days prior to the installation of monuments, Contractor shall deliver brass markers to the Engineer for the stamping of the land surveyor’s license number on the disks.

Survey monument in pavement shall be installed after the final lift of paving is completed and after the City Surveyor has set temporary straddle survey points. If permanent asphalt concrete paving cannot be placed the same day that the monument frame and collar are installed, Contractor shall place and maintain temporary asphalt concrete until the permanent pavement is placed.

**SP26-02 MEASUREMENT AND PAYMENT**

The Contract Price paid per each for **“Install New Monument”** shall include full compensation for furnishing all labor, supervision, materials, tools, equipment and incidentals necessary; including but not limited to- excavation; removing and restoration of asphalt concrete pavement; removal and disposal of existing monuments; concrete collar; placement, maintenance, and removal of temporary asphalt concrete around the monument, and all other work to completely install the monument in place as shown on the Plans, as specified in these Special Provisions, and as directed by the Engineer, and no additional compensation shall be allowed therefor.

**SPECIAL PROVISIONS SECTION SP-27**  
**MISCELLANEOUS CONSTRUCTION**  
(BID ITEM NO. 34-36 and 53-54)**SP27-01 GENERAL**

Miscellaneous work covered under this section includes:

- Shoulder backing
- Re-grade earth ditch
- Reset brick paver surfaces
- Remove and reset dry stacked rock wall
- Remove and reset brick curb

**SP27-02 SHOULDER BACKING**

Contractor shall place shoulder backing along the edge of the finish course of all new asphalt concrete paving that is not confined by a concrete gutter or other paving. Shoulder backing shall also be placed behind curbs and berms, and other similar vertical edges of construction or void space to either buttress the improvement or conform the work to surrounding grades. Shoulder backing shall consist of clean native material, select fill, aggregate base, or pulverized material to best match the existing surrounding condition. Prior to placing shoulder backing all deleterious material such as leaves and mulch shall be removed from the area to be covered with shoulder backing. Select fill and pulverized materials shall have maximum-size aggregates less than two (2) inches and be free of organic particles. Aggregate base shall be Class II conforming to SP-19.

Shoulder backing along unconfined edges of pavement is typically 4 feet wide, placed to the top of pavement finished grade, and sloped to match adjacent grades at a maximum slope of 3 to 1, horizontal to vertical. Shoulder backing behind tops of berms and curbs shall be within half an inch of top of curb/berm, and sloped to match adjacent grades as described above. Materials shall be appropriately moisture-conditioned prior to placement. Select fill shall be compacted to 90% relative compaction. Aggregate base and pulverized material shall be compacted to 95% relative

compaction. Shoulder backing shall be trimmed neatly and compacted in place on the same day that the material is placed.

Conform between new pavement or improvements and decorative gravel driveways or shoulders shall be treated as shoulder backing. When disturbing such driveways and shoulders, Contractor shall salvage sufficient existing gravel to allow for the construction of conforms. If necessary, Contractor shall import new material in kind.

#### **SP27-03 RE-GRADE EARTH DITCH**

At the location shown on the Plans and at locations designated by the Engineer, Contractor shall grade the existing earth ditch, removing all earth, vegetation, and root matter to restore positive drainage and provide a neatly-trimmed, well-defined, compacted, and stable embankment on both sides of the ditch.

#### **SP27-04 REMOVE AND RESET DRY STACKED ROCK WALL**

Contractor shall salvage with care all rocks to be reused and reset. Damaged rocks shall be replaced in kind to equal the pre-existing appearance, function, and quality. Rocks shall be keyed into the existing ground to a minimum depth of 6-inches and set to match the appearance of adjacent undisturbed sections of wall. Rock wall shall be backfilled, graded and compacted to 90% relative compaction to match surrounding undisturbed areas in grade and materials.

#### **SP27-05 RESET BRICK PAVERS**

Contractor shall salvage with care all brick pavers to be reused and reset. Damaged and broken pavers shall be replaced in kind to equal the pre-existing appearance, function, and quality. Pavers shall be set on sand or mortar to match the existing surrounding condition. Cutting shall be to a neat, straight line, with no cut unit having a minimum dimension less than three (3) inches. For pavers set in sand, a fine sand course shall be swept over the finished surface, then vibrated to lock the paver units in place.

#### **SP27-06 REMOVE AND RESET BRICK CURB**

Contractor shall salvage with care all bricks to be reused and reset. Damaged and broken bricks shall be replaced in kind to equal the pre-existing appearance, function, and quality. Pavers shall be set in mortar to match the existing surrounding condition.

#### **SP27-07 MEASUREMENT AND PAYMENT**

The Contract price paid per linear foot for “**Shoulder Backing**” shall be considered as full compensation for furnishing all labor, tools, equipment, and incidentals and for doing all work involved, including but not limited to- providing, placing, and compacting fill material, and all other work as shown on the Plans, as specified in these Special Provisions, and as directed by the Engineer, and no additional compensation shall be allowed therefor.

The Contract price paid per linear foot for **“Re-grade Earth Ditch”** shall include full compensation for furnishing all labor, tools, equipment, and incidentals and for doing all work involved, including but not limited to- removing vegetation, excavation, hauling and disposal of spoils, grading, and all other work as shown on the Plans, as specified in these Special Provisions, and as directed by the Engineer, and no additional compensation shall be allowed therefor.

The Contract price paid per square foot for **“Reset Brick Paver Surfacing”** shall include full compensation for furnishing all labor, tools, equipment, and incidentals to perform all work to salvage, store, protect, and reset brick pavers, including replacement of damaged units, as shown on the Plans, as specified in these Special Provisions, and as directed by the Engineer, and no additional compensation shall be allowed therefor.

The Contract price paid per square foot for **“Remove and Reset Dry Stacked Rock Wall”** and **“Remove and Reset Brick Curb”** shall include full compensation for furnishing all labor, tools, equipment, and incidentals to perform all work to salvage, store, protect, and reset dry stacked rock wall and brick curb, including replacement of damaged or lost rocks and bricks, as shown on the Plans, as specified in these Special Provisions, and as directed by the Engineer, and no additional compensation shall be allowed therefor.

## **SPECIAL PROVISIONS SECTION SP-28**

### **TRAFFIC SIGN**

(BID ITEM NO. 55-57)

The provisions of Section 16, “Traffic Signs,” of the Technical Specifications of the Standard Specifications shall apply in their entirety except as modified or supplemented herein.

#### **SP28-01 GENERAL**

To relocate signs, existing posts to be removed shall be completely removed and the excavation backfilled with material matching the surrounding area and adjacent grades.

At no additional cost to the City, Contractor shall replace all signs damaged by Contractor’s operations or lost while in Contractor’s possession.

Signs posts shall be galvanized 1 ¾” Ulti-Mate square post systems or approved equal.

Warning signs shall be Yellow in color green or lime green signs shall not be used.

All road signs shall be installed with a minimum of 7’ of vertical clearance measured from the lowest point of the sign panel to the ground surface.

**SP28-02 MEASUREMENT AND PAYMENT**

The Contract Price paid per each for **“Relocate Traffic Sign on New Post”**, **“Remove Traffic Sign and Post”**, and **“Install Traffic Sign and Post”** shall include full compensation for furnishing all labor, supervision, materials, tools, equipment, and incidentals, and for doing the work involved in removing existing signs and posts where designated, disposal of said existing posts and foundations, backfilling excavations, installing signs on new posts complete in place, including mounting hardware and new sign panels where required, and all other work as shown on the Plans, as specified by these Special Provisions, and as directed by the Engineer, and no additional compensation shall be allowed therefor.

# APPENDICES

# **APPENDIX A**

## **WASTE MANAGEMENT PLAN INSTRUCTIONS**





## Planning & Building Department

3675 Mt. Diablo Boulevard, Suite 210  
Lafayette, CA 94549-1968  
Tel. (925) 284-1976 • Fax (925) 284-1122  
<http://www.ci.lafayette.ca.us>

### WASTE MANAGEMENT PLAN INSTRUCTIONS CONSTRUCTION AND DEMOLITION DEBRIS RECYCLING

#### GENERAL

The City of Lafayette is mandated by the State of California to divert 50-percent of all solid waste from landfills either by salvage or recycling. To help meet this goal, the City requires completion of a Waste Management Plan (WMP) for covered projects identifying how at least 50-percent of project waste materials will be diverted from the landfill. A "covered project" is defined as:

1. Construction, renovation, and demolition projects where the total costs are projected to be equal to or greater than \$50,000; and/or
2. Construction or renovation projects equal to or greater than 1,000 sq. ft.; and/or
3. Demolition projects equal to or greater than 300 sq. ft.

All phases of a project and all related projects taking place on single or adjoining parcels are considered a single project.

#### GREEN HALO SYSTEMS

For a covered project, applicants are required to submit their WMP to the City using Green Halo Systems. Green Halo is a free web-based service for waste diversion and recycling tracking. Through Green Halo, applicants can establish, monitor and document their waste management plan and compliance online. Applicants can set-up a Green Halo account at [www.greenhalosystems.com](http://www.greenhalosystems.com). For applicants who do not have access to the internet, Green Halo can set-up an account over the phone at 1-888-525-1301. Once an applicant has created a Green Halo account, they can track and manage multiple projects for different jurisdictions on their account.

#### PROCEDURE

Prior to issuance of a grading, demolition, and/or building permit for a covered project:

1. Submit a non-refundable administrative fee, payable to the City of Lafayette. See "[Planning Fees](#)" handout for current rate.
2. Submit a WMP to the City using Green Halo that includes the following:
  - a) Identification of all the **materials** you estimate will be recycled, salvaged, or disposed; and
  - b) Identification of which [certified C&D facilities](#) the various material types will go.
3. Green Halo will notify the City that a WMP has been submitted. The City will review the submitted WMP on Green Halo. The WMP will only be approved when all of the following conditions have been met:
  - a) The WMP provides all information noted above; and
  - b) The WMP indicates that at least 50% of all construction and demolition debris generated by the project will be diverted.
4. The WMP will be approved or not approved. If the WMP is incomplete and/or fails to meet the required diversion rate, the WMP will not be approved and the applicant will be notified about the reasons for non-approval. No grading, building, and/or demolition permit will be issued until the WMP is approved.

#### INFEASIBILITY EXEMPTION

If an applicant for a covered project experiences unique circumstances that make it infeasible to comply with the diversion requirement, the applicant may apply for an exemption at the time the WMP is submitted. Increased costs to the applicant generally will not be a sufficient basis for an exemption. The applicant shall indicate on the WMP the minimum rate of diversion he/she believes is feasible for each material and the specific circumstances that he/she believes make it infeasible to comply with the diversion requirement.

## **UPON COMPLETION OF THE PROJECT**

Prior to the final inspection of a grading, demolition, and/or building permit and within 30 days after project completion, the applicant shall submit their WMP to the City through Green Halo for final review. The goal of the final review is to provide documentation to the City showing that the diversion requirement has been met. The WMP submitted for final review shall include the following:

1. Receipts from the certified facilities that collected or received each material showing the actual volume or weight of the material received and how the material was disposed of; and
2. Any additional information the applicant believes is relevant to determining its efforts to comply in good faith with the diversion requirement.

Through Green Halo, the City will review the WMP and documentation noted above and a determination will be made if the applicant has complied with the diversion requirement as follows:

1. **Full compliance** - If the applicant has fully complied with the diversion requirement.
2. **Good Faith Effort to Comply** - If the diversion requirement has not been achieved, the City will determine on a case-by-case basis whether the applicant has made a good faith effort to comply with the diversion requirement. In making this determination, the City will consider the availability of markets for the C&D debris landfilled, the size of the project and the documented efforts of the applicant to divert the C&D debris.
3. **Noncompliance** - If the City determines that the applicant has not complied with the diversion requirement, the City may withhold final project approval until full compliance can be established.

**No hold on final shall be released, until the WMP has been provided to and approved by the City as either full compliance or good faith effort to comply.**

## **NONCOMPLIANCE**

Please note that if the required documentation is not submitted and approved by the City, or the applicant has not made a good faith effort to comply, the applicant is in noncompliance status and is in violation of the Lafayette Municipal Code (LMC) and is liable for a civil penalty, or any other remedy provided in the LMC. This violation makes the property owner liable to the City for a civil penalty of \$1,000 or one percent (1%) of the project cost, whichever is less. The project will not be approved and holds will not be released, until the project is in full compliance, meets the good faith effort to comply, or the civil penalty has been paid.

## **APPEAL**

Appeal of the determination made by the City shall be made to the City Council within 30 days of the City's determination. To appeal, an applicant must submit a letter to the city manager concisely stating the facts of the case and the grounds of appeal. The city manager will schedule a meeting before the city council and notify the applicant of the date, time, and place. The decision of the city council is final. Appeals shall be limited to:

1. The granting or denial of an exemption; or
2. Whether the applicant has made a good faith effort to comply with the WMP.

**NOTE:** The applicant and property owner are responsible for the actions of their contractors or other agents with regard to the diversion requirement. Therefore, when reviewing proposals from project managers, contractors, site cleanup, vendors, and other building professionals, all aspects of the proposal should be considered and not just the cost.

# **APPENDIX B**

## **STANDARD PLANS**





DIST COUNTY ROUTE POST MILES SHEET TOTALS  
 REGISTERED CIVIL ENGINEER  
 May 20, 2011  
 PLANS APPROVAL DATE  
 THE STATE OF CALIFORNIA  
 DEPARTMENT OF TRANSPORTATION  
 DIVISION OF HIGHWAYS  
 OFFICE OF THE PLANNING ENGINEER

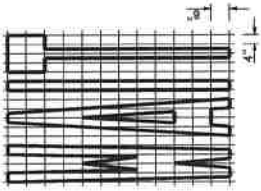

A=19 ft+2

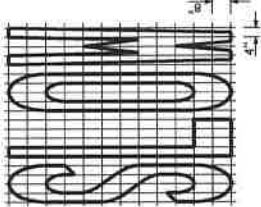

A=23 ft+2

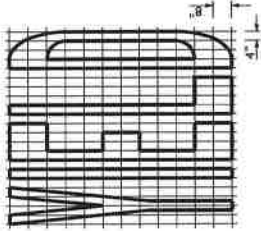

A=24 ft+2

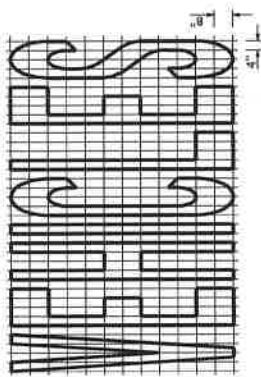

A=42 ft+2

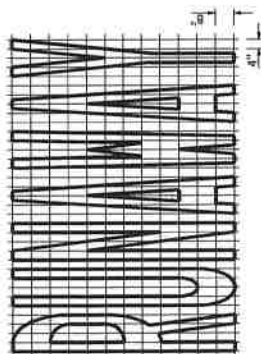

A=43 ft+2

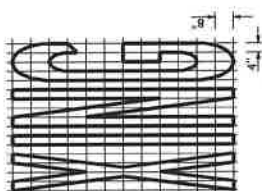

A=21 ft+2

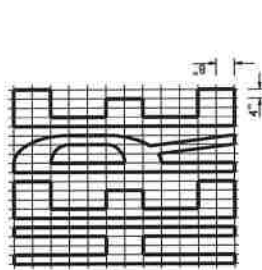

A=26 ft+2

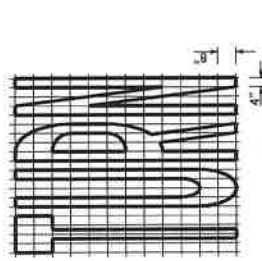

A=24 ft+2

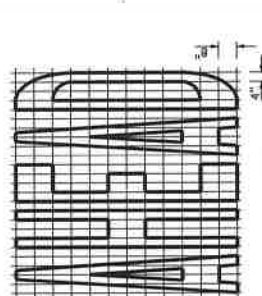

A=31 ft+2

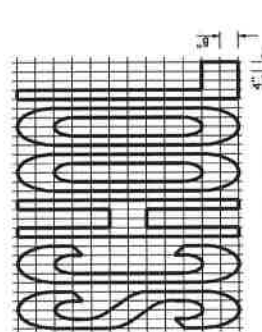

A=35 ft+2

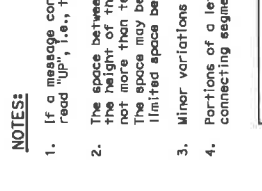

A=18 ft+2

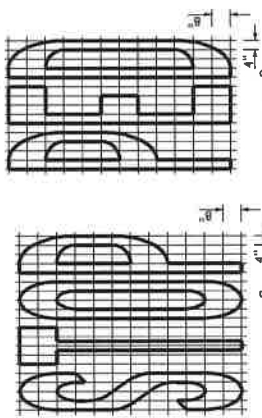

A=22 ft+2

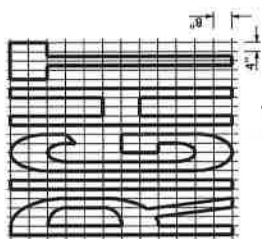

A=26 ft+2

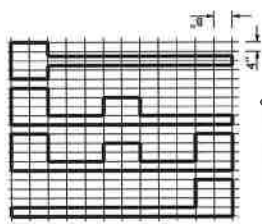

A=19 ft+2

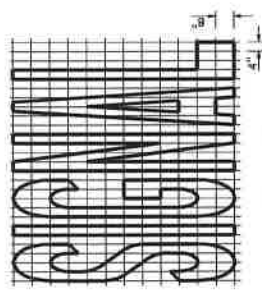

A=32 ft+2

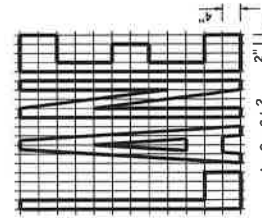

A=6 ft+2

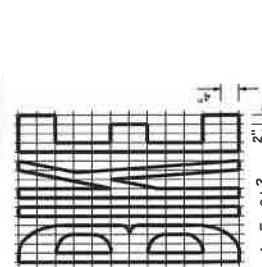

A=5 ft+2

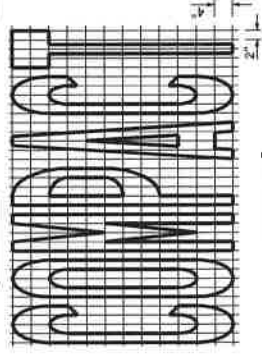

A=10 ft+2

NOTES:

- If a message consists of more than one word, it should read "up", i.e., the first word should be nearest the driver.
- The space between words should be at least four times the height of the characters. The height of the characters should not be more than ten times the height of the characters. The space may be reduced appropriately where there is limited space because of local conditions.
- Minor variations in dimensions may be accepted by the Engineer.
- Portions of a letter, number or symbol may be separated by connecting segments not to exceed 2" in width.

WORD MARKINGS

ITEM	ft+2	ITEM	ft+2	ITEM	ft+2
XING	21	YIELD	24	BIKE	5
AHEAD	31	SCHOOL	35	SLOW	23
WAIT	19	SIGNAL	32	STOP	22
LANE	6	TURN	24	LEFT	19
RIGHT	26	HERE	26	VEHICLES	42
				COMPACT	10
				RUNAWAY	43

STATE OF CALIFORNIA  
 DEPARTMENT OF TRANSPORTATION  
**PAVEMENT MARKINGS**  
**WORDS**  
 NO SCALE

A24D

October 30, 2015

STATE OF CALIFORNIA  
DEPARTMENT OF TRANSPORTATION

PROJECT: [Blank]  
SHEET: [Blank]

**CURB QUANTITIES**

TYPE	CUBIC YARDS PER LINEAR FOOT
A1-6	0.02584
A1-8	0.03084
A2-6	0.05903
A2-8	0.06379
A3-6	0.01036
A3-8	0.01435
B1-4	0.02185
B1-6	0.02930
B2-4	0.05515
B3-4	0.06171
B3-6	0.00641
B4	0.05709
D-4	0.04093
D-6	0.06804
E	0.06661

**TABLE A**

CURB TYPE	DIMENSIONS			
	"H1"	"H2"	"W1"	"W2"
A1-6	1'-2"	6"	7 1/2"	1 1/2"
A1-8	1'-4"	8"	8"	2"
A2-6	1'-0"	6"	2'-7 1/2"	1 1/2"
A2-8	1'-2"	8"	2'-8"	2"
A3-6	6"	5"	7 1/2"	1 1/2"
A3-8	8"	7"	7 1/2"	1 1/2"
B1-4	1'-0"	4"	7 1/2"	2 1/2"
B1-6	1'-2"	6"	9"	4"
B2-4	1'-0"	4"	2'-7 1/2"	2 1/2"
B2-6	1'-0"	6"	2'-9"	4"
B3-4	4"	3"	7"	2"
B3-6	6"	5"	8 1/2"	3 1/2"
D-4	1'-0"	4"	1'-6"	1'-1"
D-6	1'-0"	6"	2'-2"	1'-9"

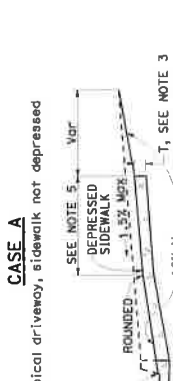
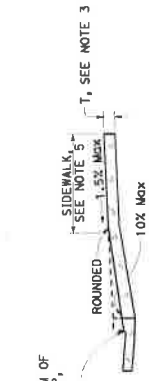

**SECTIONS**

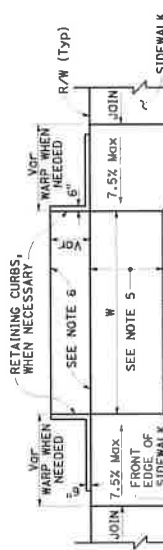

**DRIVEWAYS**

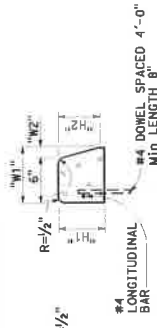

**CURBS**

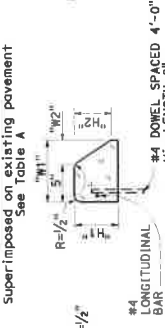

**NOTES:**

- Case A driveway section typically applies.
- X=3'-0" except for curb heights over 10" where 4:1 slopes shall be used on curb slope.
- Sidewalk and ramp thickness "T" at driveway shall be 4" for residential and 6" for commercial.
- Difference in slope of the driveway ramp and the roadway 5'-0" from gutter line shall not exceed 15%. Reduce driveway ramp slope, not gutter slope, where required.
- Minimum width of clear passageway for sidewalk shall be 4'-2".
- Retaining curbs and acquisition of construction easement may be necessary for narrow sidewalks or curb heights in excess of 6".
- Across the pedestrian route at curb ramp locations, the gutter pan slope shall not exceed 1" of depth for each 2'-0" of width.

STATE ROUTE NUMBER 1234 56789  
 COUNTY 1234 56789  
 PROJECT NUMBER 1234 56789  
 DATE 12/31/2010  
 DRAWN BY 1234 56789  
 CHECKED BY 1234 56789  
 APPROVED BY 1234 56789  
 TITLE 1234 56789  
 SCALE 1234 56789  
 SHEET NO. 1234 56789  
 TOTAL SHEETS 1234 56789

TO ACCOMPANY PLANS DATED \_\_\_\_\_

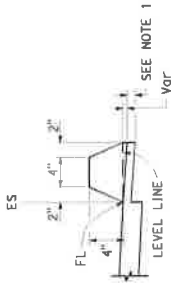

**TYPE F**  
See Note 5



**TYPE E**



**TYPE D**

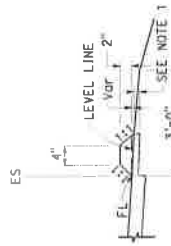

**TYPE C**

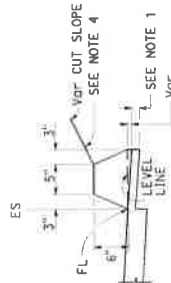

**TYPE A**  
See Notes 3 and 5

**DIKES**

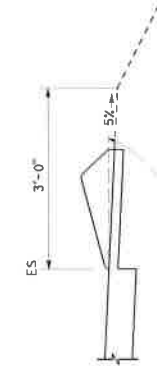

**CASE R**  
See Note 2

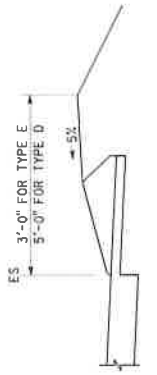

**CASE F**



**CASE C-2**  
Cut Slope

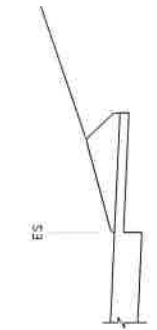

**CASE C-1**  
Cut Slope

**TYPE D AND E BACKFILL DETAILS**

**DIKE QUANTITIES**

TYPE	CUBIC YARDS PER LINEAR FOOT
A	0.0135
C	0.0038
D	0.0293
E	0.0130
F	0.0066

Quantities based on 5% cross slope.

- NOTES:**
- For HMA shoulders only, extend top layer of HMA placed on the shoulder under dike with no joint at the ES. For projects with OGFC shoulders, do not extend OGFC under dike. See project plans for modified dike details.
  - Case R applies to retrofit only projects where restrictive conditions do not provide enough width for Case F backfill.
  - Type A dike only to be used where restrictive slope conditions do not provide enough width to use Type D or Type E dike.
  - Fill and compact with excavated material to top of dike.
  - Use Type A or F dike where dike is required with guardrail installations. See Revised Standard Plan RSP A77M4 for dike positioning details. See Revised Standard Plan RSP A77N3 for hinge point offsets with guardrail.

STATE OF CALIFORNIA  
DEPARTMENT OF TRANSPORTATION

**HOT MIX ASPHALT DIKES**

NO SCALE

RSP A87B DATED JANUARY 15, 2016 SUPERSEDES RSP A87B DATED JULY 19, 2013 AND STANDARD PLAN A87B DATED MAY 20, 2011 - PAGE 120 OF THE STANDARD PLANS BOOK DATED 2010.

**REVISED STANDARD PLAN RSP A87B**



Victor Smith  
 License No. 41957  
 State of California  
 July 3, 2015

TO ACCOMPANY PLANS DATED \_\_\_\_\_

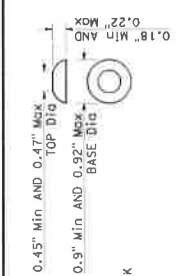

**RAISED TRUNCATED DOME**

**NOTES:**

- As site conditions dictate, Case A through Case G curb ramps may be used. The minimum slope shall be 1.5% and shall be shown on the detail. The case G curb ramp may be used at mid block locations, as site conditions dictate.
- If distance from curb to back of sidewalk is too short to accommodate ramp and 4'-2" platform (landing) as shown in Case A, the sidewalk may be depressed longitudinally as in Case B, or C or may be widened as in Case D.
- When ramp is located in center of curb return, crosswalk configuration must be similar to that shown for Detail B.
- As site conditions dictate, the retaining curb side and the flared side of the Case G ramp shall be constructed in reversed position.
- If located on a curve, the sides of the ramp need not be parallel, but the minimum width of the ramp shall be 4'-2".
- Side slope of ramp flares vary uniformly from a maximum of 9.0% of curb to conform with longitudinal sidewalk slope adjacent to top of the ramp, except in Case C and Case F.
- Transitions from ramps and landing to walks, gutters or streets shall be flush (no lip) and free of abrupt changes.
- Counter slopes of adjoining gutters and road surfaces immediately adjacent to and within 24 inches of the curb ramp shall not be steeper than 1:20 (5.0%). Gutter pan slope shall not exceed 1" of depth for each 2'-0" of width.
- Curb ramps shall have a detectable warning surface that extends the full width and 3'-0" depth of the ramp. A 4'-0" wide detectable warning surface shall be provided for ramps that do not conform to the requirements in the Standard Specifications.
- Sidewalk and ramp thickness, "T", shall be 3/2" minimum.
- Utility pull boxes, manholes, vaults and all other utility facilities within the boundaries of the curb ramp will be relocated or adjusted to grade by the owner prior to, or in conjunction with, curb ramp construction.
- Detectable warning surface may have to be cut to allow removal of utility covers while maintaining full detectable warning width and depth.



**RAISED TRUNCATED DOME PATTERN (IN-LINE)**  
 DETECTABLE WARNING SURFACE

See Note 9

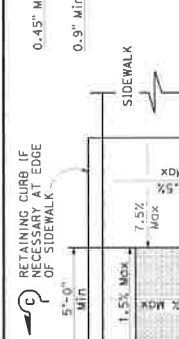

**CASE C**

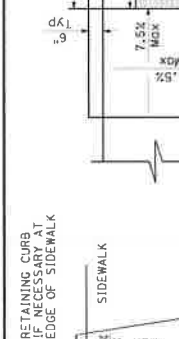

**CASE B**

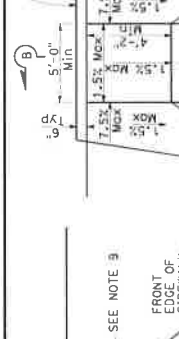

**CASE A**

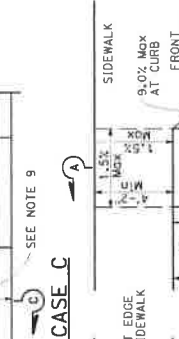

**CASE F**

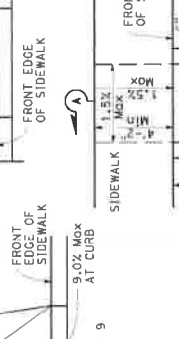

**CASE E**

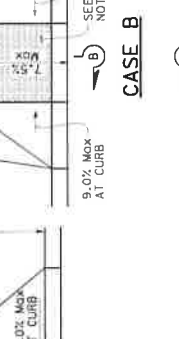

**CASE D**

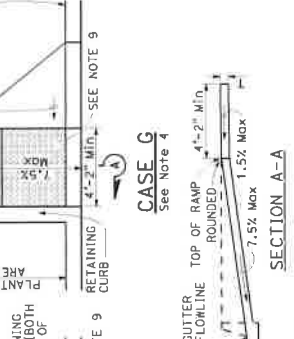

**CASE G**

See Note 4

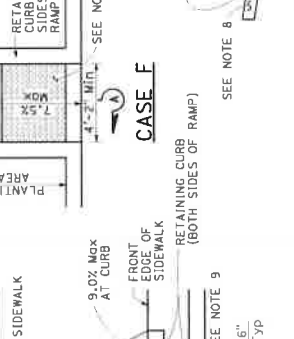

**CASE G**

See Note 4

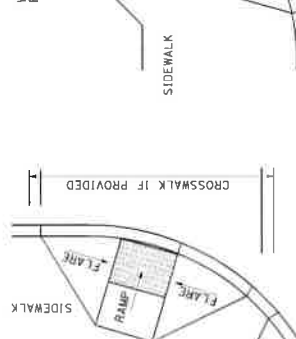
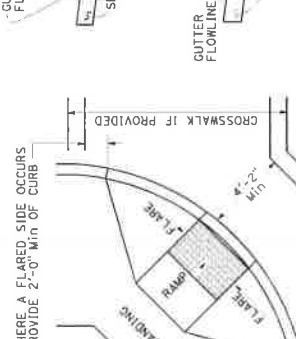
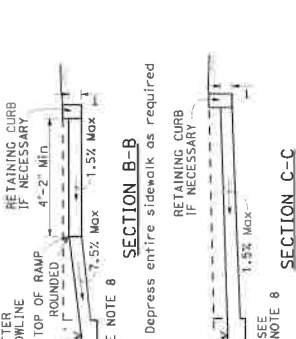

Depress entire sidewalk as required

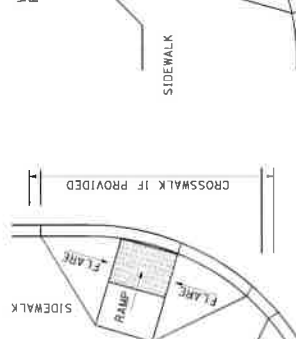
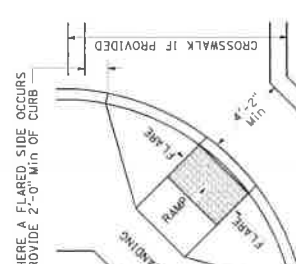

**TYPICAL ONE-RAMP CORNER INSTALLATION**  
 See Notes 1 and 3

**TYPICAL TWO-RAMP CORNER INSTALLATION**  
 See Note 1

STATE OF CALIFORNIA  
 DEPARTMENT OF TRANSPORTATION  
**CURB RAMP DETAILS**  
 NO SCALE

RSP A88A DATED JULY 3, 2015 SUPERSEDES RSP A88A DATED MARCH 21, 2014 AND RSP A88A DATED MAY 19, 2011. SEE PAGE 121 OF THE STANDARD PLANS BOOK DATED 2010.

**REVISED STANDARD PLAN RSP A88A**

Victor S. Garcia
   
 July 3, 2015
   
 TO ACCOMPANY PLANS DATED \_\_\_\_\_

**NOTES:**

1. Sidewalk, ramp and passageway thickness, "T", shall be 3 1/2" minimum.
2. For details of detectable warning surfaces, see Revised Standard Plan RSP A88A.
3. Where an island passageway length is greater than or equal to 6'-0", but less than 8'-0", each detectable warning surface shall extend the full width of the island passageway length. Where an island passageway length is greater than or equal to 8'-0", each detectable warning surface shall extend the full width and 3'-0" depth of the passageway length. A 4'-0" wide detectable warning surface may be used on a 4'-2" wide island passageway.
4. Transitions from ramps to walks, gutters or streets shall be flush (no lip) and free of abrupt changes.
5. Utility vault bases, manholes, vaults and all other utility facilities within the boundaries of the curb ramp will be relocated or adjusted to grade by the owner prior to, or in conjunction with, curb ramp construction.
6. Detectable warning surface may have to be cut to allow removal of utility covers while maintaining full detectable warning width and depth.
7. For additional curb ramp details, see Revised Standard Plan RSP A88A.

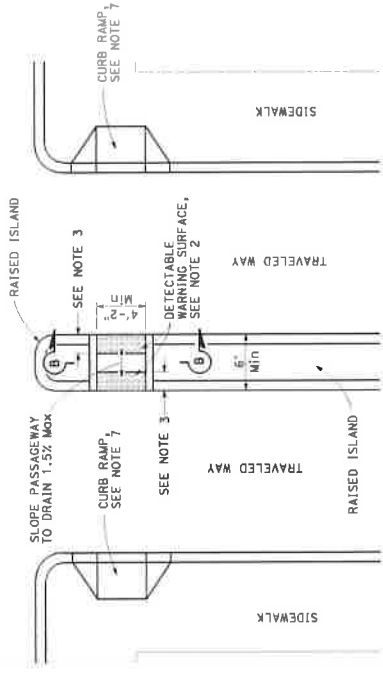

**TYPE A PASSAGEWAY**

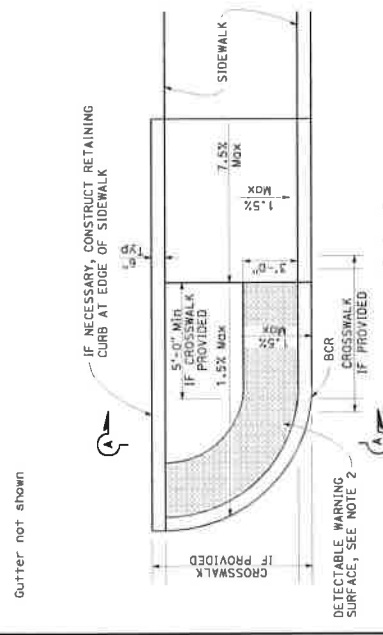

**CASE CM CURB RAMP**

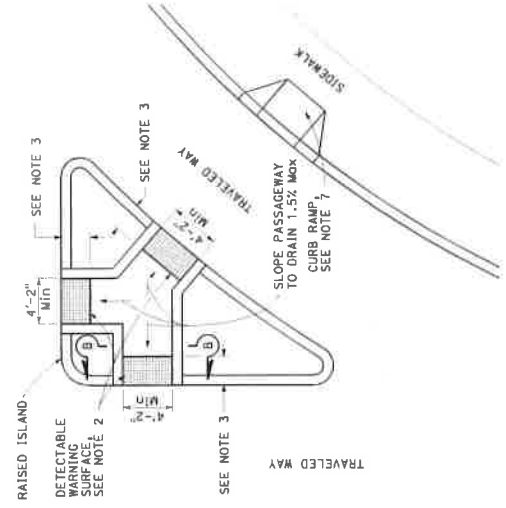

**TYPE B PASSAGEWAY**

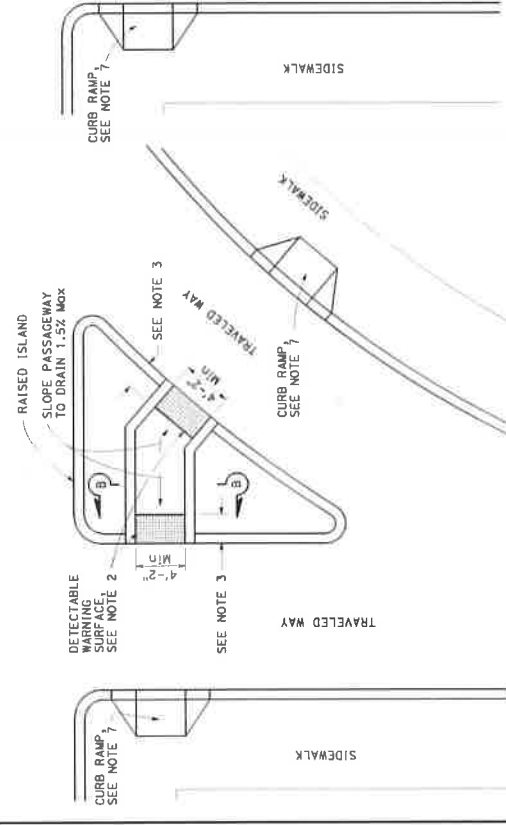

**TYPE C PASSAGEWAY**

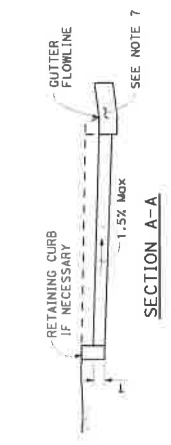

**SECTION A-A**

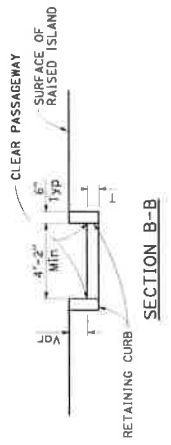

**SECTION B-B**

STATE OF CALIFORNIA  
DEPARTMENT OF TRANSPORTATION

**CURB RAMP AND ISLAND PASSAGEWAY DETAILS**

NO SCALE

RSP A88B DATED JULY 3, 2015 SUPERSEDES RSP A88B DATED MARCH 21, 2014, AND RSP A88B DATED JULY 3, 2013. STANDARD PLAN A88B DATED MAY 26, 2011 - PAGE 122 OF THE STANDARD PLANS BOOK DATED 2010.

**REVISED STANDARD PLAN RSP A88B**

STATE COUNTY ROUTE "SOUTH PROJECT" DISTRICT

**Raymond C. Jaffe**  
REGISTERED CIVIL ENGINEER  
No. 10000  
EXPIRES 12/31/14

APR 11 19 2013

STATE OF CALIFORNIA  
DIVISION OF HIGHWAYS  
DIVISION OF HIGHWAY MATERIALS  
DIVISION OF HIGHWAY DESIGN

TO ACCOMPANY PLANS DATED \_\_\_\_\_

**NOTES:**

1. Grate type numbers refer to approximate width of grate in inches and number of bars, respectively.
2. Contractor has the option of using cast ductile iron, cast carbon steel, welded, or cast end block grate.
3. Rounded top of bars optional on all grates.
4. Pipe inlets with a grate shall be placed so that bars parallel direction of principle surface flow.
5. Complete joint penetration butt welds may be substituted for the fillet welds on all anchors.
6. Standard square, hexagon, round or equivalent headed anchors may be substituted for the right angle hooks on the anchors shown on this plan.
7. Grate and frame weights are based on steps, protection bars, etc. are not included.
8. Connect chain to grate and frame only at locations shown on the plans. When chain required, do not use cast ductile iron grates.

**CAST END BLOCK**

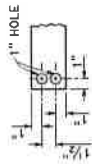

**END OF BAR**

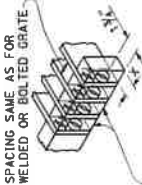

SPACING SAME AS FOR WELDED OR BOLTED GRATE

BOTH ENDS HELD TOGETHER BY SOLID CASTING

**ALTERNATIVE CAST DUCTILE IRON OR CAST CARBON STEEL END BLOCK GRATE**

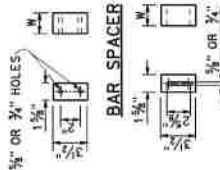

W = 1 1/2" or 2"

**ALTERNATIVE SPACER**

DETAIL "D"  
(Steel grates only)

STATE OF CALIFORNIA  
DEPARTMENT OF TRANSPORTATION

**GRATE DETAILS No. 1**

NO SCALE

RSP D77A DATED APRIL 19, 2013 SUPERSEDES RSP D77A DATED JULY 20, 2012 AND STANDARD PLAN D77A DATED MAY 20, 2011 - PAGE 164 OF THE STANDARD PLANS BOOK DATED 2010.

**REVISED STANDARD PLAN RSP D77A**

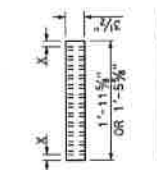

**DETAIL "C"**



**SECTION A-A**



**ALTERNATIVE CAST DUCTILE IRON GRATE OR CAST CARBON STEEL GRATE**

**WELDED GRATE**

**SECTION B-B**

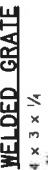

**SECTION C-C**



**BOLTED END BLOCK**



**BOLTING DETAIL**



**ALTERNATIVE BOLTED GRATE**

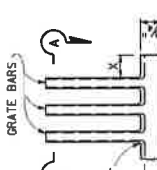

**DETAIL "C"**



**SECTION A-A**



**ALTERNATIVE CAST DUCTILE IRON GRATE OR CAST CARBON STEEL GRATE**

**WELDED GRATE**

**SECTION B-B**



**SECTION C-C**



**BOLTED END BLOCK**



**BOLTING DETAIL**



**ALTERNATIVE BOLTED GRATE**

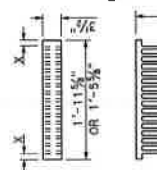

**DETAIL "C"**



**SECTION A-A**



**ALTERNATIVE CAST DUCTILE IRON GRATE OR CAST CARBON STEEL GRATE**

**WELDED GRATE**

**SECTION B-B**



**SECTION C-C**



**BOLTED END BLOCK**



**BOLTING DETAIL**



**ALTERNATIVE BOLTED GRATE**

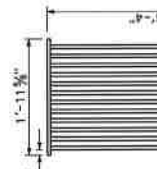

**DETAIL "C"**



**SECTION A-A**

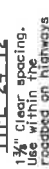

**ALTERNATIVE CAST DUCTILE IRON GRATE OR CAST CARBON STEEL GRATE**

**WELDED GRATE**

**SECTION B-B**

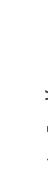

**SECTION C-C**



**BOLTED END BLOCK**



**BOLTING DETAIL**



**ALTERNATIVE BOLTED GRATE**

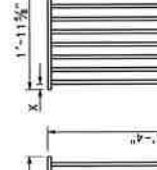

**DETAIL "C"**



**SECTION A-A**

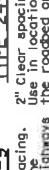

**ALTERNATIVE CAST DUCTILE IRON GRATE OR CAST CARBON STEEL GRATE**

**WELDED GRATE**

**SECTION B-B**

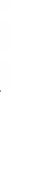

**SECTION C-C**

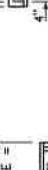

**BOLTED END BLOCK**

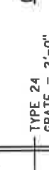

**BOLTING DETAIL**

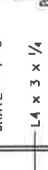

**ALTERNATIVE BOLTED GRATE**

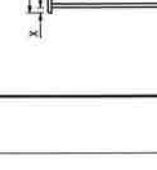

**DETAIL "C"**



**SECTION A-A**



**ALTERNATIVE CAST DUCTILE IRON GRATE OR CAST CARBON STEEL GRATE**

**WELDED GRATE**

**SECTION B-B**



**SECTION C-C**



**BOLTED END BLOCK**



**BOLTING DETAIL**

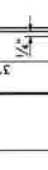

**ALTERNATIVE BOLTED GRATE**

**ALTERNATIVE ANCHOR FOR RECTANGULAR FRAME**  
(For details not shown, See Rectangular Frame Details)

INLET TYPE GRATE TYPE NO. OF GRATES WEIGHT LB

G00	24-12	2	634
G0L-7	24-12	1	326
G0L-10	24-12	1	326
G0, G1, G2, G3, G4 (TYPE 24)	24-9	1	263
	24-12	1	326
G4 (TYPE 18), G5, G6	18-9	1	249
G11	18-9	2	498
G12	18-9	2	498
G13	24-12	2	652
G14	24-12	2	652
TRASH RACK			22
GRATE CHAIN			3

**RECTANGULAR FRAME DETAILS**  
(For all rectangular grates)

INLET TYPE COVER TYPE WEIGHT LB

05	PLATE	174
0L-7	PLATE	170
0L-10	PLATE	170
0L-14	PLATE	170
0L-21	PLATE	170
0CP	PLATE	112
0CP1	PLATE	112
0CP2	REDWOOD	42
0MP	PLATE	177
0MP1	PLATE	177

**GRATE BAR SPACING TABLE**

No. OF BARS CLEAR BAR SPACING X

18-9	9	1 1/2"
24-9	9	2"
24-12	12	1 3/4"

**BASIS FOR MISCELLANEOUS IRON & STEEL FINAL PAY WEIGHTS FOR DRAINAGE INLETS**

(See Note 7)

COUNTY ROUTE TOTAL SQUARE FEET PER SHEET  
 PROJECT NO. 03-30-13  
 DATE APR 11 19, 2013  
 REVISIONS CIVIL ENGINEER  
 APPROVED BY THE COUNTY ENGINEER  
 APPROVED BY THE COUNTY ENGINEER  
 APPROVED BY THE COUNTY ENGINEER

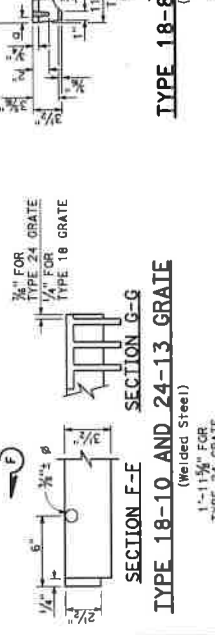
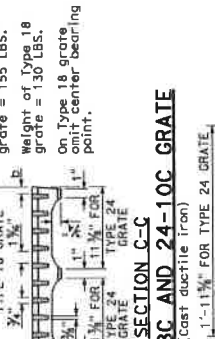
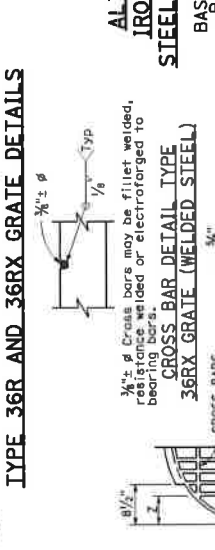
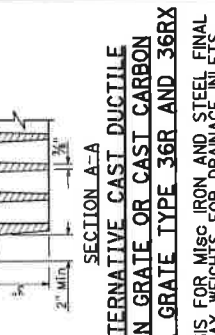
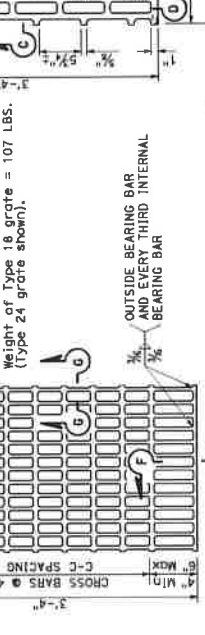
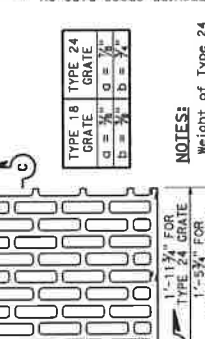
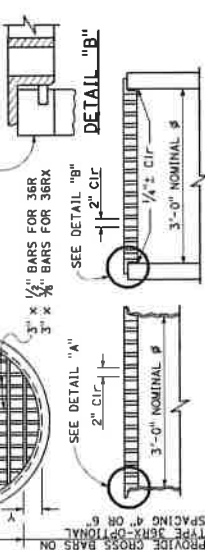
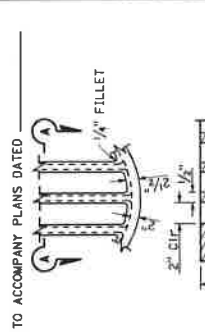
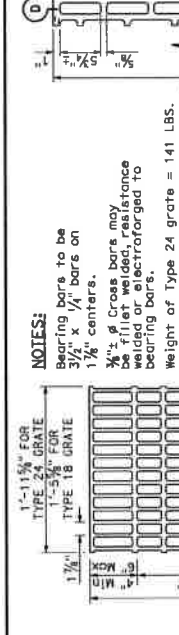
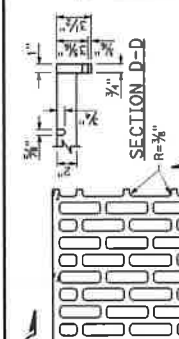

INLET TYPE	GRATE TYPE	NO. OF GRATES	WEIGHT LB
GDD	24-10C	2	391
(SEE NOTE 4)	24-10S	2	456
	24-12X	2	473
	24-13	2	374
G0, G0L, G1, G2, G3, G4	24-10C	1	202
(TYPE 24)	24-10S	1	229
	24-12X	1	239
	24-13	1	188
G4 (TYPE 18)	18-8S	1	187
G5, G6	18-9X	1	187
	18-10	1	149
	18-8S	2	374
	18-9X	2	374
	18-10	2	298
	24-10C	2	404
	24-10S	2	458
	24-12X	2	478
	24-13	2	378
	36R (Mod)	1	196
	36R	1	215
	36R (WOOD)	1	220
	36R	1	236
	TRASH RACK	1	22
	GRATE CHAIN	1	3

TYPE	NO. OF BARS	CLEAR BAR SPACING	X SPACING	Y SPACING	Z
36R	13	2"	2"	6"	-
36RX (STEEL)	15	2"	2"	3 1/4"	5 1/4"
36RX (CAST)	12	2"	2"	3 1/4"	5 1/4"
36R MOD	12	2"	2"	3 1/4"	5 1/4"
36RX MOD (STEEL)	13	2"	2"	3 1/4"	5 1/4"
36RX MOD (CAST)	12	2"	2"	3 1/4"	5 1/4"

**NOTES:**  
 1. When alternative grates are allowed - Final pay based on alternative with the lesser weight.  
 2. Use frame shown on Standard Plan D74A, D74B or RSP D77A as appropriate.  
 3. When Type 24-10S, 24-12X or 24-13 grates are used with GDD Inlets, the 3/4" x 1/4" x 3/8" Inlet frame to separate the individual grates.  
 4. See Revised Standard Plan RSP D77A for connecting chain to welded grate and frame, when chain is required, do not use cast ductile iron grate.

**NOTES:**  
 Bearing bars to be 3/2" x 1/4" bars on 1 1/2" centers.  
 12 Bars for Type 24 grate - 9 bars for Type 18 grates. (Type 24 grate shown).  
 Weight of Type 24 grate = 192 LBS.  
 Weight of Type 18 grate = 145 LBS.  
 3/4" x 1/4" Cross bars may be fillet welded, resistance welded or electroformed to bearing bars.

STATE OF CALIFORNIA  
 DEPARTMENT OF TRANSPORTATION  
**GRATE DETAILS No. 2**  
 NO SCALE  
 RSP D77B DATED APRIL 19, 2013 SUPERSEDES RSP D77B DATED JULY 20, 2012 AND STANDARD PLAN D77B DATED MAY 20, 2011 - PAGE 165 OF THE STANDARD PLANS BOOK DATED 2010.

TO ACCOMPANY PLANS DATED  
 REVISIONS  
 APPROVED BY THE COUNTY ENGINEER  
 APPROVED BY THE COUNTY ENGINEER  
 APPROVED BY THE COUNTY ENGINEER

SECTION A-A  
 ALTERNATIVE CAST DUCTILE IRON GRATE OR CAST CARBON STEEL GRATE TYPE 36R AND 36RX  
 BASIS FOR MISC IRON AND STEEL FINAL PAY WEIGHTS FOR DRAINAGE INLETS

SECTION B-B  
 TYPE 18-8S AND 24-10S GRATE  
 (Welded Steel) Reticuline type

SECTION C-C  
 TYPE 18-8C AND 24-10C GRATE  
 (Cast ductile iron)

SECTION D-D  
 TYPE 18 GRATE AND TYPE 24 GRATE

SECTION E-E  
 TYPE 18 GRATE AND TYPE 24 GRATE

SECTION F-F  
 TYPE 18-8S AND 24-10S GRATE  
 (Welded Steel) Reticuline type

SECTION G-G  
 TYPE 18-10 AND 24-13 GRATE  
 (Welded Steel)

SECTION H-H  
 TYPE 18-8S AND 24-10S GRATE  
 (Welded Steel) Reticuline type

SECTION I-I  
 TYPE 18-8S AND 24-10S GRATE  
 (Welded Steel) Reticuline type

SECTION J-J  
 TYPE 18-8S AND 24-10S GRATE  
 (Welded Steel) Reticuline type

SECTION K-K  
 TYPE 18-8S AND 24-10S GRATE  
 (Welded Steel) Reticuline type

SECTION L-L  
 TYPE 18-8S AND 24-10S GRATE  
 (Welded Steel) Reticuline type

SECTION M-M  
 TYPE 18-8S AND 24-10S GRATE  
 (Welded Steel) Reticuline type

SECTION N-N  
 TYPE 18-8S AND 24-10S GRATE  
 (Welded Steel) Reticuline type

SECTION O-O  
 TYPE 18-8S AND 24-10S GRATE  
 (Welded Steel) Reticuline type

SECTION P-P  
 TYPE 18-8S AND 24-10S GRATE  
 (Welded Steel) Reticuline type

SECTION Q-Q  
 TYPE 18-8S AND 24-10S GRATE  
 (Welded Steel) Reticuline type

SECTION R-R  
 TYPE 18-8S AND 24-10S GRATE  
 (Welded Steel) Reticuline type

SECTION S-S  
 TYPE 18-8S AND 24-10S GRATE  
 (Welded Steel) Reticuline type

SECTION T-T  
 TYPE 18-8S AND 24-10S GRATE  
 (Welded Steel) Reticuline type

SECTION U-U  
 TYPE 18-8S AND 24-10S GRATE  
 (Welded Steel) Reticuline type

SECTION V-V  
 TYPE 18-8S AND 24-10S GRATE  
 (Welded Steel) Reticuline type

SECTION W-W  
 TYPE 18-8S AND 24-10S GRATE  
 (Welded Steel) Reticuline type

SECTION X-X  
 TYPE 18-8S AND 24-10S GRATE  
 (Welded Steel) Reticuline type

SECTION Y-Y  
 TYPE 18-8S AND 24-10S GRATE  
 (Welded Steel) Reticuline type

SECTION Z-Z  
 TYPE 18-8S AND 24-10S GRATE  
 (Welded Steel) Reticuline type

SECTION AA-AA  
 TYPE 18-8S AND 24-10S GRATE  
 (Welded Steel) Reticuline type

SECTION BB-BB  
 TYPE 18-8S AND 24-10S GRATE  
 (Welded Steel) Reticuline type

SECTION CC-CC  
 TYPE 18-8S AND 24-10S GRATE  
 (Welded Steel) Reticuline type

SECTION DD-DD  
 TYPE 18-8S AND 24-10S GRATE  
 (Welded Steel) Reticuline type

SECTION EE-EE  
 TYPE 18-8S AND 24-10S GRATE  
 (Welded Steel) Reticuline type

SECTION FF-FF  
 TYPE 18-8S AND 24-10S GRATE  
 (Welded Steel) Reticuline type

SECTION GG-GG  
 TYPE 18-8S AND 24-10S GRATE  
 (Welded Steel) Reticuline type

SECTION HH-HH  
 TYPE 18-8S AND 24-10S GRATE  
 (Welded Steel) Reticuline type

SECTION II-II  
 TYPE 18-8S AND 24-10S GRATE  
 (Welded Steel) Reticuline type

SECTION JJ-JJ  
 TYPE 18-8S AND 24-10S GRATE  
 (Welded Steel) Reticuline type

SECTION KK-KK  
 TYPE 18-8S AND 24-10S GRATE  
 (Welded Steel) Reticuline type

SECTION LL-LL  
 TYPE 18-8S AND 24-10S GRATE  
 (Welded Steel) Reticuline type

SECTION MM-MM  
 TYPE 18-8S AND 24-10S GRATE  
 (Welded Steel) Reticuline type

SECTION NN-NN  
 TYPE 18-8S AND 24-10S GRATE  
 (Welded Steel) Reticuline type

SECTION OO-OO  
 TYPE 18-8S AND 24-10S GRATE  
 (Welded Steel) Reticuline type

SECTION PP-PP  
 TYPE 18-8S AND 24-10S GRATE  
 (Welded Steel) Reticuline type

SECTION QQ-QQ  
 TYPE 18-8S AND 24-10S GRATE  
 (Welded Steel) Reticuline type

SECTION RR-RR  
 TYPE 18-8S AND 24-10S GRATE  
 (Welded Steel) Reticuline type

SECTION SS-SS  
 TYPE 18-8S AND 24-10S GRATE  
 (Welded Steel) Reticuline type

SECTION TT-TT  
 TYPE 18-8S AND 24-10S GRATE  
 (Welded Steel) Reticuline type

SECTION UU-UU  
 TYPE 18-8S AND 24-10S GRATE  
 (Welded Steel) Reticuline type

SECTION VV-VV  
 TYPE 18-8S AND 24-10S GRATE  
 (Welded Steel) Reticuline type

SECTION WW-WW  
 TYPE 18-8S AND 24-10S GRATE  
 (Welded Steel) Reticuline type

SECTION XX-XX  
 TYPE 18-8S AND 24-10S GRATE  
 (Welded Steel) Reticuline type

SECTION YY-YY  
 TYPE 18-8S AND 24-10S GRATE  
 (Welded Steel) Reticuline type

SECTION ZZ-ZZ  
 TYPE 18-8S AND 24-10S GRATE  
 (Welded Steel) Reticuline type

SECTION AA-AA  
 TYPE 18-8S AND 24-10S GRATE  
 (Welded Steel) Reticuline type

SECTION BB-BB  
 TYPE 18-8S AND 24-10S GRATE  
 (Welded Steel) Reticuline type

SECTION CC-CC  
 TYPE 18-8S AND 24-10S GRATE  
 (Welded Steel) Reticuline type

SECTION DD-DD  
 TYPE 18-8S AND 24-10S GRATE  
 (Welded Steel) Reticuline type

SECTION EE-EE  
 TYPE 18-8S AND 24-10S GRATE  
 (Welded Steel) Reticuline type

SECTION FF-FF  
 TYPE 18-8S AND 24-10S GRATE  
 (Welded Steel) Reticuline type

SECTION GG-GG  
 TYPE 18-8S AND 24-10S GRATE  
 (Welded Steel) Reticuline type

SECTION HH-HH  
 TYPE 18-8S AND 24-10S GRATE  
 (Welded Steel) Reticuline type

SECTION II-II  
 TYPE 18-8S AND 24-10S GRATE  
 (Welded Steel) Reticuline type

SECTION JJ-JJ  
 TYPE 18-8S AND 24-10S GRATE  
 (Welded Steel) Reticuline type

SECTION KK-KK  
 TYPE 18-8S AND 24-10S GRATE  
 (Welded Steel) Reticuline type

SECTION LL-LL  
 TYPE 18-8S AND 24-10S GRATE  
 (Welded Steel) Reticuline type

SECTION MM-MM  
 TYPE 18-8S AND 24-10S GRATE  
 (Welded Steel) Reticuline type

SECTION NN-NN  
 TYPE 18-8S AND 24-10S GRATE  
 (Welded Steel) Reticuline type

SECTION OO-OO  
 TYPE 18-8S AND 24-10S GRATE  
 (Welded Steel) Reticuline type

SECTION PP-PP  
 TYPE 18-8S AND 24-10S GRATE  
 (Welded Steel) Reticuline type

SECTION QQ-QQ  
 TYPE 18-8S AND 24-10S GRATE  
 (Welded Steel) Reticuline type

SECTION RR-RR  
 TYPE 18-8S AND 24-10S GRATE  
 (Welded Steel) Reticuline type

SECTION SS-SS  
 TYPE 18-8S AND 24-10S GRATE  
 (Welded Steel) Reticuline type

SECTION TT-TT  
 TYPE 18-8S AND 24-10S GRATE  
 (Welded Steel) Reticuline type

SECTION UU-UU  
 TYPE 18-8S AND 24-10S GRATE  
 (Welded Steel) Reticuline type

SECTION VV-VV  
 TYPE 18-8S AND 24-10S GRATE  
 (Welded Steel) Reticuline type

SECTION WW-WW  
 TYPE 18-8S AND 24-10S GRATE  
 (Welded Steel) Reticuline type

SECTION XX-XX  
 TYPE 18-8S AND 24-10S GRATE  
 (Welded Steel) Reticuline type

SECTION YY-YY  
 TYPE 18-8S AND 24-10S GRATE  
 (Welded Steel) Reticuline type

SECTION ZZ-ZZ  
 TYPE 18-8S AND 24-10S GRATE  
 (Welded Steel) Reticuline type

SECTION AA-AA  
 TYPE 18-8S AND 24-10S GRATE  
 (Welded Steel) Reticuline type

SECTION BB-BB  
 TYPE 18-8S AND 24-10S GRATE  
 (Welded Steel) Reticuline type

SECTION CC-CC  
 TYPE 18-8S AND 24-10S GRATE  
 (Welded Steel) Reticuline type

SECTION DD-DD  
 TYPE 18-8S AND 24-10S GRATE  
 (Welded Steel) Reticuline type

SECTION EE-EE  
 TYPE 18-8S AND 24-10S GRATE  
 (Welded Steel) Reticuline type

SECTION FF-FF  
 TYPE 18-8S AND 24-10S GRATE  
 (Welded Steel) Reticuline type

SECTION GG-GG  
 TYPE 18-8S AND 24-10S GRATE  
 (Welded Steel) Reticuline type

SECTION HH-HH  
 TYPE 18-8S AND 24-10S GRATE  
 (Welded Steel) Reticuline type

SECTION II-II  
 TYPE 18-8S AND 24-10S GRATE  
 (Welded Steel) Reticuline type

SECTION JJ-JJ  
 TYPE 18-8S AND 24-10S GRATE  
 (Welded Steel) Reticuline type

SECTION KK-KK  
 TYPE 18-8S AND 24-10S GRATE  
 (Welded Steel) Reticuline type

SECTION LL-LL  
 TYPE 18-8S AND 24-10S GRATE  
 (Welded Steel) Reticuline type

SECTION MM-MM  
 TYPE 18-8S AND 24-10S GRATE  
 (Welded Steel) Reticuline type

SECTION NN-NN  
 TYPE 18-8S AND 24-10S GRATE  
 (Welded Steel) Reticuline type

SECTION OO-OO  
 TYPE 18-8S AND 24-10S GRATE  
 (Welded Steel) Reticuline type

SECTION PP-PP  
 TYPE 18-8S AND 24-10S GRATE  
 (Welded Steel) Reticuline type

SECTION QQ-QQ  
 TYPE 18-8S AND 24-10S GRATE  
 (Welded Steel) Reticuline type

SECTION RR-RR  
 TYPE 18-8S AND 24-10S GRATE  
 (Welded Steel) Reticuline type

SECTION SS-SS  
 TYPE 18-8S AND 24-10S GRATE  
 (Welded Steel) Reticuline type

SECTION TT-TT  
 TYPE 18-8S AND 24-10S GRATE  
 (Welded Steel) Reticuline type

SECTION UU-UU  
 TYPE 18-8S AND 24-10S GRATE  
 (Welded Steel) Reticuline type

SECTION VV-VV  
 TYPE 18-8S AND 24-10S GRATE  
 (Welded Steel) Reticuline type

SECTION WW-WW  
 TYPE 18-8S AND 24-10S GRATE  
 (Welded Steel) Reticuline type

SECTION XX-XX  
 TYPE 18-8S AND 24-10S GRATE  
 (Welded Steel) Reticuline type

SECTION YY-YY  
 TYPE 18-8S AND 24-10S GRATE  
 (Welded Steel) Reticuline type

SECTION ZZ-ZZ  
 TYPE 18-8S AND 24-10S GRATE  
 (Welded Steel) Reticuline type

SECTION AA-AA  
 TYPE 18-8S AND 24-10S GRATE  
 (Welded Steel) Reticuline type

SECTION BB-BB  
 TYPE 18-8S AND 24-10S GRATE  
 (Welded Steel) Reticuline type

SECTION CC-CC  
 TYPE 18-8S AND 24-10S GRATE  
 (Welded Steel) Reticuline type

SECTION DD-DD  
 TYPE 18-8S AND 24-10S GRATE  
 (Welded Steel) Reticuline type

SECTION EE-EE  
 TYPE 18-8S AND 24-10S GRATE  
 (Welded Steel) Reticuline type

SECTION FF-FF  
 TYPE 18-8S AND 24-10S GRATE  
 (Welded Steel) Reticuline type

SECTION GG-GG  
 TYPE 18-8S AND 24-10S GRATE  
 (Welded Steel) Reticuline type

SECTION HH-HH  
 TYPE 18-8S AND 24-10S GRATE  
 (Welded Steel) Reticuline type

CONTRA COSTA COUNTY  
STANDARD PLANS





STD. PLAN CA71

**JULIA R. BEREN**  
 LICENSE NO. 37937  
 STATE OF CALIFORNIA  
 CIVIL ENGINEER

*Julia R. Beren*  
 PUBLIC WORKS DIRECTOR  
 APPROVAL DATE: 02/11/2011

PLANS APPROVAL DATE

The County of Contra Costa or the officers or agents in compliance with electronic copies of this plan sheet.

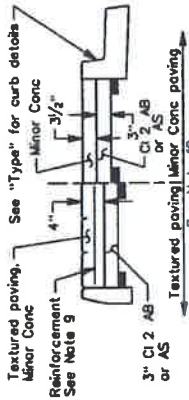

TYPICAL MEDIAN PAVING DETAIL

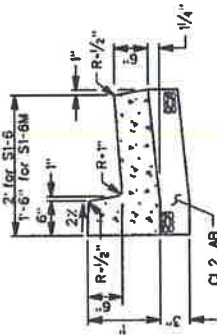

TYPE S1-6 & S1-6M



TYPE S1-8 & S1-8M

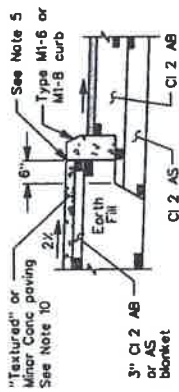

TYPE A TRAFFIC MEDIAN  
 Half Section



TYPE B TRAFFIC MEDIAN  
 Half Section

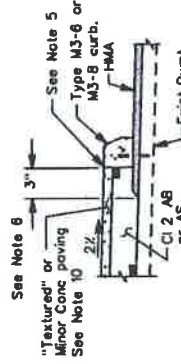

TYPE C TRAFFIC MEDIAN  
 Half Section

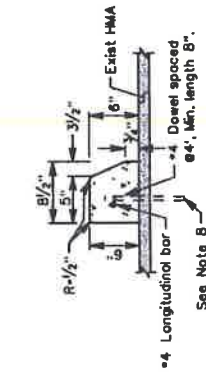

TYPE M3-6 CURB  
 See Note 6

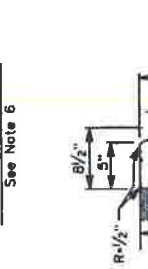

TYPE M1-6 CURB  
 See Note 7

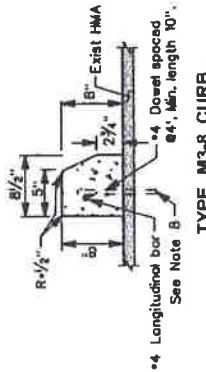

TYPE M3-8 CURB

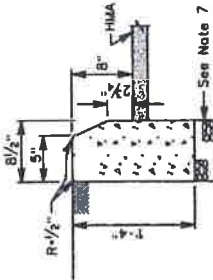

TYPE M1-8 CURB  
 See Note 7

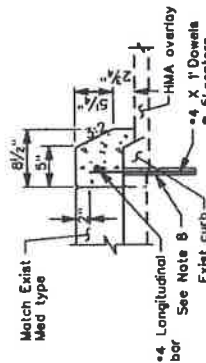

MODIFIED TYPE M3-8 CURB

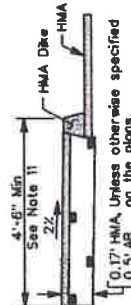

HMA PATH WITH HMA DIKE

NOTES:

- Minor Concrete in conformance with Section 90-2, "Minor Concrete" of the California Department of Transportation's Standard Specifications containing no less than 505 lb. per cubic yard of cementitious material shall be used for all concrete construction detailed on this plan.
- Weakened plane joints shall be provided at 10' intervals on all curbs. See Standard Plan CA70, "Detail B".
- All new curb where it conforms to existing facilities shall be detailed as per Standard Plan CA74.
- When the street slopes away from the curb, the gutter slope shall match the cross slope of the street. Paving at the gutter lip shall conform to Standard Plan CA70 Detail A, except that where the street slopes away from the curb, the paving shall match the gutter lip.
- Curb may be constructed monolithically with the median paving, in which case a weakened plane joint conforming to Standard Plan CA70 Detail B shall be provided along the back of the curb, overlaid pavement.
- A 3" minimum compacted layer of Class 2 aggregate base or subbase shall be placed under Type M1 curb, unless noted otherwise on the plans.
- Place dowels in 1" diameter drilled hole filled with 1:1 sand grout. Dmt dowels when curb is estruited.
- Reinforcement shall be #4 bars at 18" OC each way or 6" x 6", 8" x 8", 10 gage welded wire fabric.
- Median paving may be "textured" as approved by the Public Works Department.
- Width of HMA path shall be a minimum of 4'-6" measured from top face of curb or dike.

COUNTY OF CONTRA COSTA  
 PUBLIC WORKS DEPARTMENT  
 MARTINEZ, CALIFORNIA

STANDARD PLAN

MEDIAN, CURB AND HMA DIKE  
 DETAILS

SCALE: NO SCALE  
 DRAWN BY: H. HUSSEY  
 CHECKED BY: M. HOLLINSWORTH

DATE: 3/14  
 PLAN NO: CA71

NO.	DATE	REVISION DESCRIPTION



*Julia R. Buffren*  
 PUBLIC WORKS DIRECTOR  
 March 11, 2014  
 PLANS APPROVAL DATE

PROFESSIONAL ENGINEER  
 JULIA R. BUFFREN  
 CIVIL  
 No. 37937  
 STATE OF CALIFORNIA

The County of Contra Costa or its officers or agents shall not be held responsible for the consequences of any errors or omissions of any kind.

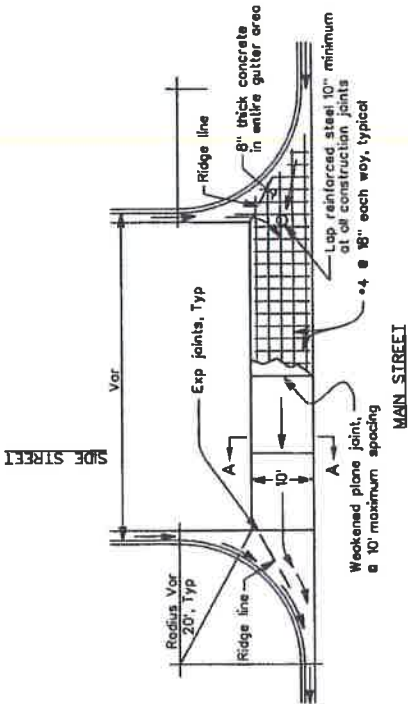

TYPICAL PLAN - VALLEY GUTTER

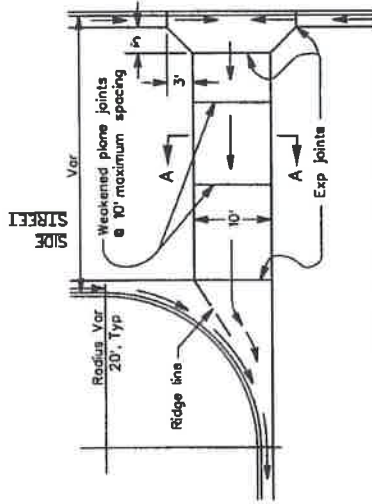

JUNCTION PLAN - VALLEY GUTTER

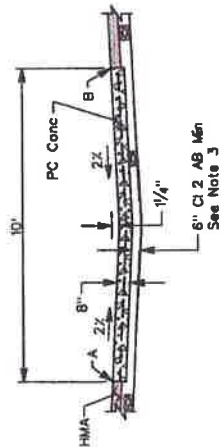

SECTION A-A

**NOTES:**

1. Valley gutters shall only be used on local roads or roads with a low volume of traffic as approved by the Public Works Department.
2. Concrete to be used for all construction shown on this plan and shall contain a minimum of 580 lbs per cubic yard of cementitious material, 1" maximum aggregate grading in conformance with Section 90, "Concrete" of the California Department of Transportation Standard Specifications.
3. If pavement structural section thickness of side street exceeds 14", aggregate base thickness shall be increased to match total side street pavement structural section thickness.
4. For weakened plane joint and expansion joint details, see details on Standard Plan CA70.

COUNTY OF CONTRA COSTA  
 PUBLIC WORKS DEPARTMENT  
 MARTINEZ, CALIFORNIA

STANDARD PLAN

**CONCRETE VALLEY GUTTER  
 DETAILS**

NO.	DATE	REVISION DESCRIPTION	BY	CHECKED BY: M. HILLIGSMITH

SCALE: NO SCALE  
 DATE: 3/14  
 DRAWN BY: H. HUSSEY  
 PLAN NO: CA73

PUBLIC WORKS DIRECTOR  
 JULIA R. BUEREN  
 No. 37937  
 CIVIL  
 STATE OF CALIFORNIA

APPROVAL DATE: March 11, 2014

The County of Contra Costa or its officers or agents shall not be responsible for the accuracy or completeness of electronic copies of this plan sheet.

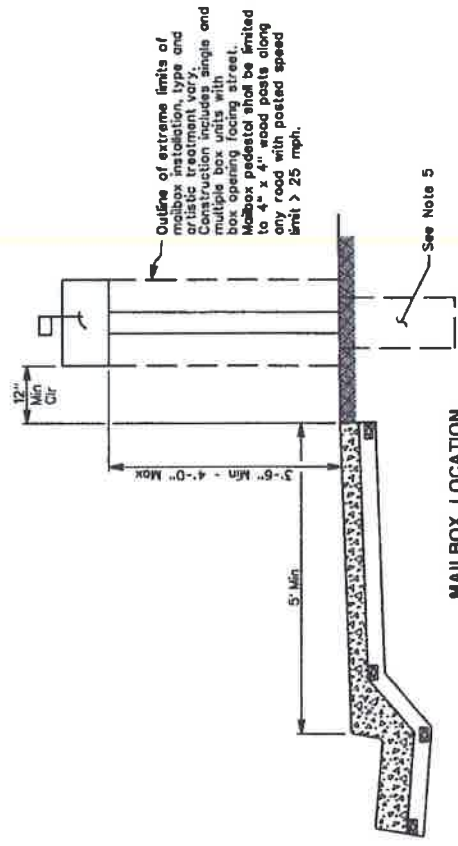

**MAILBOX LOCATION**  
Monolithic curb and sidewalk

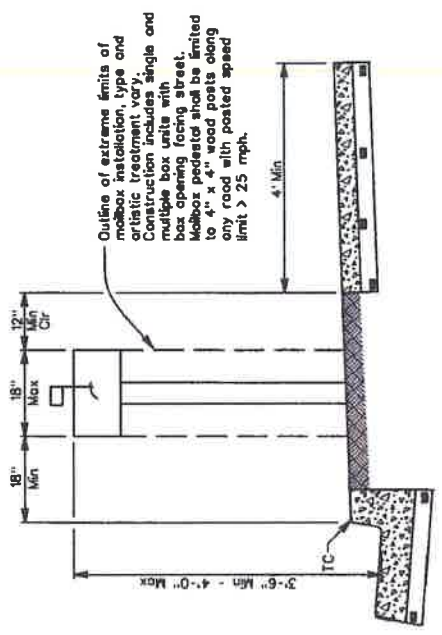

**MAILBOX LOCATION**  
Separated sidewalk with planting strip

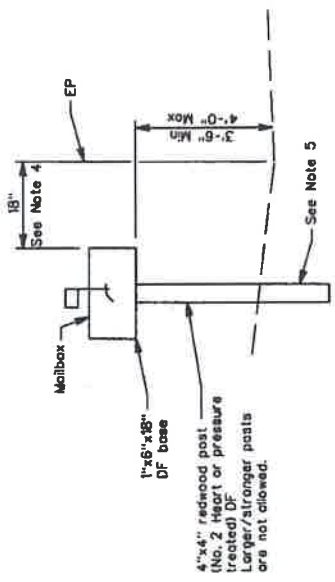

**RURAL MAILBOX DETAIL**

**NOTES:**

- Distances are established by Postal regulations and may vary depending on jurisdiction. Check with local Post Office for current regulations.
- Erection permit is required if mailbox is to be installed in existing sidewalk, or if installation requires modification of dimensions shown on this plan.
- See Standard Plan CA70 & CA71 for sidewalk and curb details.
- Where AC drive or curb is placed at edge of pavement, the minimum distance is measured from the face of curb or drive.
- Post depth shall be as required to adequately support mailbox to be installed. Minimum 2' depth with compacted soil backfill, no PCC backfill.

COUNTY OF CONTRA COSTA  
 PUBLIC WORKS DEPARTMENT  
 MARTINEZ, CALIFORNIA  
 STANDARD PLAN

**MAILBOX DETAILS**

SCALE: NO SCALE  
 DATE: 3/14

DRAWN BY: H. HUSSEY  
 CHECKED BY: W. HOLLINGSWORTH

PLAN NO: **CA90**

NO	DATE	REVISION DESCRIPTION	BY

# STD. PLAN CD27

**PUBLIC WORKS DIRECTOR**  
**PLANS APPROVAL DATA**  
 JULIA R. BLEREN  
 CIVIL  
 37837  
 The County of Contra Costa or its officers or agents shall not be held liable for any errors or omissions or consequences of electronic copies of this plan sheet.

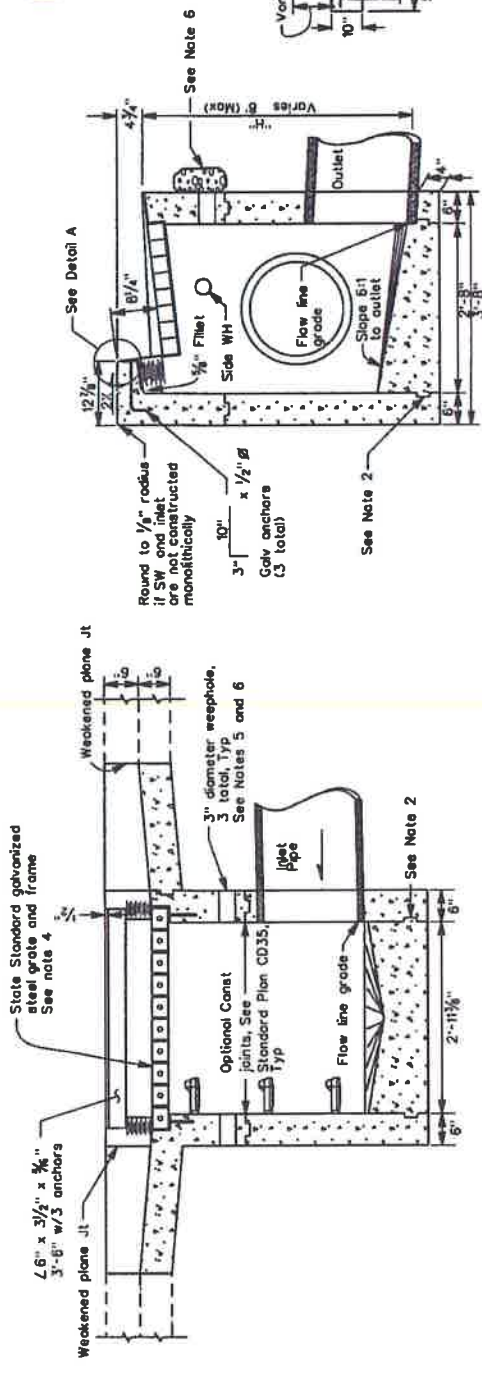

**SECTION A-A**  
NO SCALE

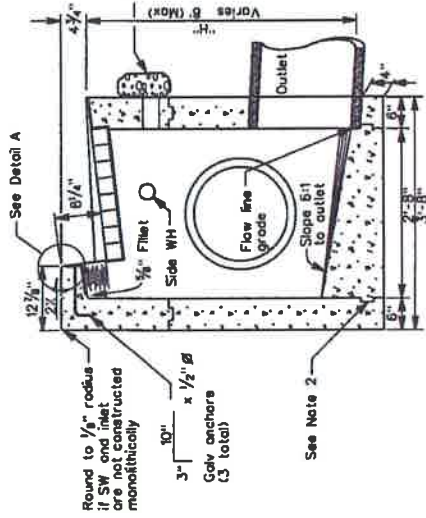

**SECTION B-B**  
NO SCALE

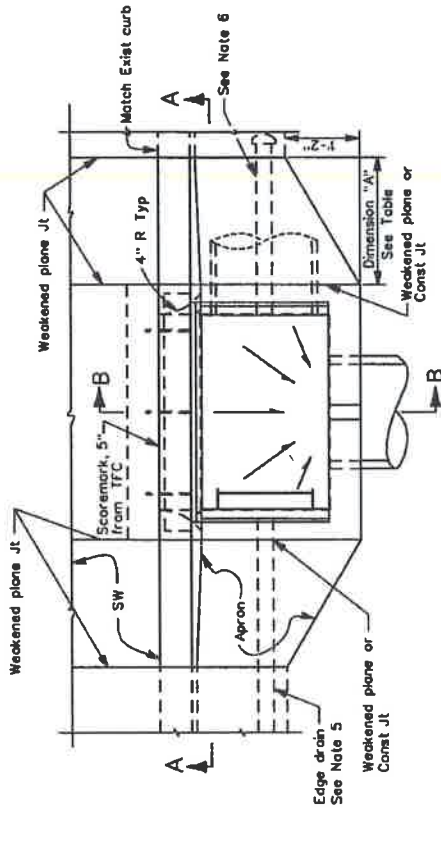

**PLAN**  
NO SCALE  
GRATE NOT SHOWN

**TABLE**

DIMENSION "A" (in)		
UPSTREAM CURB GRADE	"A" UPSTREAM	"A" DOWNSTREAM
22 and less	24	24
24 and less	36	36
37 and less	48	48
47 and less	60	60
60 and less	72	72
72 and less	84	84
84 and less	96	96
97 and greater	108	108
102 and greater	120	120

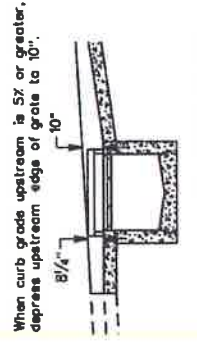

**DETAIL FOR STEEP CURB SLOPE**

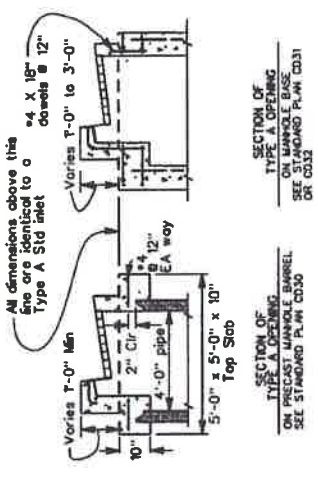

**SECTION OF TYPE A OPENING ON MANHOLE BASE**  
SEE STANDARD PLAN CD31 OR CD32

**SECTION OF TYPE A OPENING ON PRECAST MANHOLE BARREL**  
SEE STANDARD PLAN CD30

**NOTES:**

1. For Inlet General Notes and Details, see Standard Plan CD35.
2. Construction joints are optional where shown, other locations are subject to the approval of the Public Works Department. Key dimensions - 3/4" x 3".
3. When dimension "H" exceeds 6'-0", use a manhole base with Type "G" inlet top.
4. See Caltrans Standard Plan D77A for inlet frame and Caltrans Standard Plan D77B for type 24-105 inlet grate.
5. If edge drains are specified by Public Works Department or shown on the plans, see Standard Plan CD08 for edge drain (ED) details.
6. See Standard Plan CD35 for weephole drainage details unless edge drain is shown on plans or as specified by Public Works Department. For edge drain details, see Standard Plan CD08.

**COUNTY OF CONTRA COSTA**  
**PUBLIC WORKS DEPARTMENT**  
 MARTINEZ, CALIFORNIA  
 STANDARD PLAN

**TYPE "G" INLET**

SCALE: NO SCALE  
 DATE: 3/14  
 DRAWN BY: L. COSTA  
 PLAN NO: **CD27**

NO.	DATE	REVISION DESCRIPTION	BY	CHECKED BY

**PUBLIC WORKS DIRECTOR**  
**JULIA R. BUEREN**  
 No. 37937  
 CIVIL ENGINEER  
 STATE OF CALIFORNIA

*Julia R. Bueren*  
 PUBLIC WORKS DIRECTOR  
 PLANS APPROVAL DATE: **15 MAY 2014**  
 The County of Contra Costa or its officers or agents shall not be held responsible for the construction or maintenance of any work shown on this plan sheet.

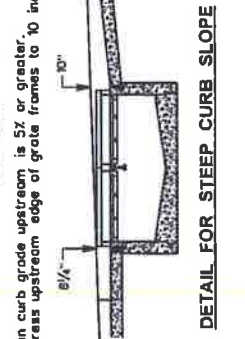
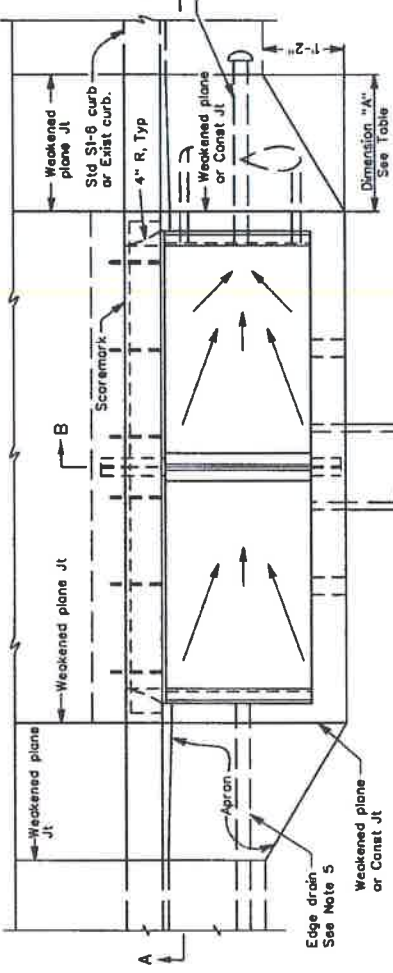
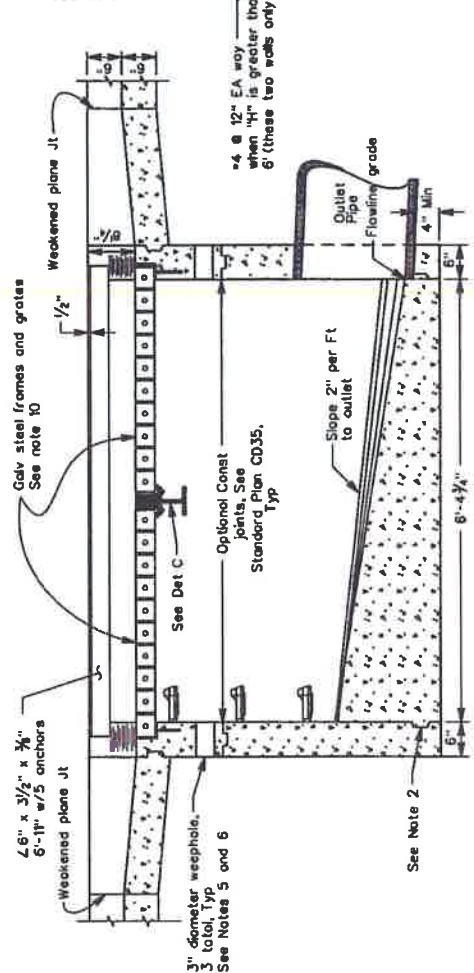
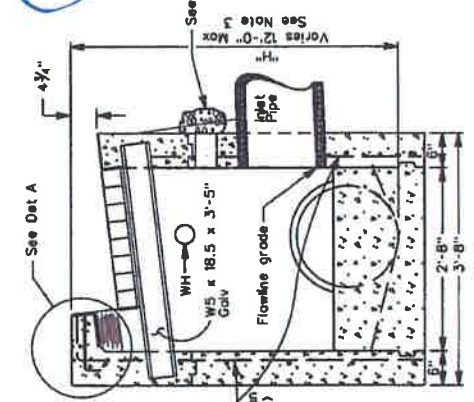

**TABLE**

**DIMENSION "A" (in)**

UPSTREAM CURB GRADE "A" UPSTREAM	"A" DOWNSTREAM
2% and flatter	24
3%	24
3.5%	24
4%	24
4.5%	24
5%	24
5.5%	24
6%	24
6.5%	24
7%	24
7.5%	24
8%	24
8.5%	24
9%	24
9.5%	24
10% and greater	170

See DETAIL FOR STEEP CURB SLOPE"

**NOTES:**

1. For Inlet General Notes and Details, see Standard Plan CD35.
2. Construction joints are optional where shown, other locations are subject to the approval of the Public Works Department. Key dimensions - 3/4" x 3".
3. When dimension "H" exceeds 12'-0", use a manhole base with Type "H" inlet top.
4. See Caltrans Standard Plan D77A for inlet frame and Caltrans Standard Plan D77B for type 24-105 inlet grate.
5. If edge drains are specified by Public Works Department or shown on the plans, see Standard Plan CD08 for edge drain (ED) details.
6. See Standard Plan CD35 for weephole drainage details unless edge drain is shown on plans or as specified by Public Works Department. For edge drain details, see Standard Plan CD08.

**COUNTY OF CONTRA COSTA**  
**PUBLIC WORKS DEPARTMENT**  
 MARTINEZ, CALIFORNIA  
 STANDARD PLAN

**TYPE "H" INLET**

SCALE: NO SCALE  
 DATE: 3/14  
 DRAWN BY: L. COSTA  
 CHECKED BY: M. HOLLINGSWORTH

PLAN NO. **CD28**

NO.	DATE	REVISION DESCRIPTION	BY

**JULIA R. BUERIN**  
 LICENSE NO. 37937  
 CIVIL ENGINEER  
 STATE OF CALIFORNIA

*Julia R. Buerin*  
 PUBLIC WORKS DIRECTOR  
 March 11, 2014  
 PLANS APPROVAL DATE

The County of Contra Costa or its officers or agents accept responsibility for the accuracy and completeness of electronic copies of this plan sheet.

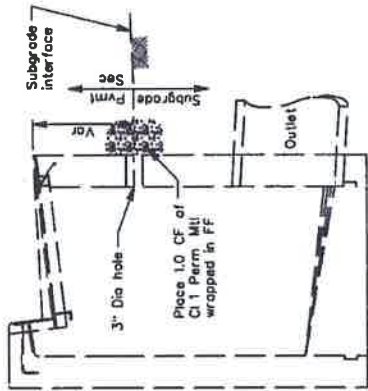
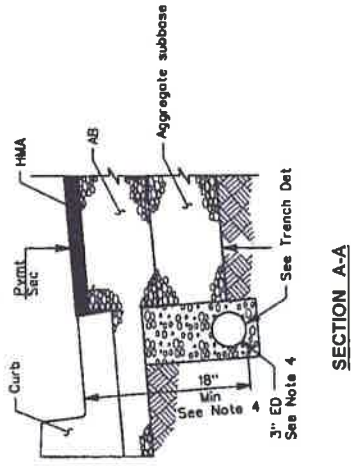
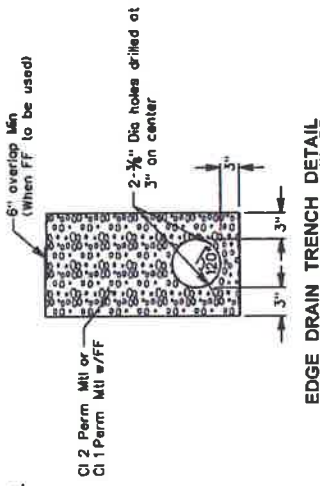
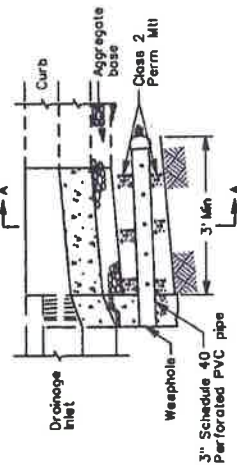
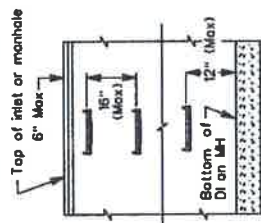

**NOTES:**

- All inlets shall have a County approved "anti-pollution" plastic marker attached to the inlet as directed by the Inspector or Resident Engineer. The marker shall be applied following manufacturer's recommendations. PCC surfaces shall be mechanically cleaned just prior to attaching the marker. The marker and adhesive may be furnished by the Public Works Department, check your permit conditions or contract Special Provisions.
- Steps shall be steel reinforced polypropylene plastic, M.A. Industries, Inc. No. P524-PF or equivalent. Steps to be cast in place or press fitted into holes per manufacturer. Install steps with lowest rung 12" maximum above the floor and highest rung not more than 6" below top of inlet. The spacing between steps shall not exceed 16" and shall be uniform throughout the length of the wall. Place steps in the wall without an opening. Steps shall not be installed on inlet back wall. No steps required where distance from floor of inlet to top of grate is 4' or less. See "Step Detail".
- Weephole elevation varies depending on the depth of the adjoining pavement section. It shall be 0" or slightly below the pavement section subgrade elevation with a minimum depth of 18" below the curb inlet grate elevation. The side weephole detail shall be located at all bump locations. Edge drain Standard Plan CD08, and weephole details shall be located at other locations. Be certain that the construction plans or by the Public Works Department. When the weephole detail or edge drains are not required, these weepholes shall conform to the front face weephole details shown on this plan.
- 3" edge drain per Standard Plan CD08, when shown on the plans or specified by the Public Works Department.
- Concrete shall conform to Section 90, "Concrete", of California Department of Transportation's Standard Specifications and the following.
  - Construction joints shown on standard plans are permitted when top portion of inlet is to be constructed monolithically with curb and sidewalk. Key dimensions: 3/4" x 3".
  - Concrete construction joint shall be located 12" to 18" below top of curb elevation.
  - Concrete above construction joint shall contain a minimum of 505 lbs of cementitious material per cubic yard, 1" maximum aggregate grading.
  - Concrete below construction joint shall contain a minimum of 590 lbs of cementitious material per cubic yard, 1" maximum aggregate grading.
  - When inlet is constructed as a single unit concrete shall comply with item D, described above.
- Type "H" manhole (Std Pin CD30) bases are for use with pipes to 24" in diameter and where there is sufficient cover to use minimum length manhole barrel, eccentric cone, and cover frame. Use Type "H" manhole bases (Std Pin CD31) with pipes to 42" in diameter. Type "M" manhole bases (Std Pin CD32) for 50" in diameter. Use Type "V" manhole bases (Std Pin CD34) for pipes up to 96" in diameter. For pipe larger than 96" in diameter, a special manhole base design is required.
- Unless otherwise noted on Standard Plans all concrete shall contain not less than 590 lbs. of cementitious material per cubic yard, 1" maximum grading in conformance with Section 90, "Concrete", of California Department of Transportation's Standard Specifications. Invert paving concrete shall contain not less than 505 lbs per cubic yard of cementitious material, 1" maximum grading, in conformance with said Standard Specifications.
- Inlet and outlet pipes shall not intercept a manhole base through a corner. If skew angle is too great to permit the opening to be made in a single wall face, use a Type "H" manhole base. (See Std Pin CD32).

COUNTY OF CONTRA COSTA  
 PUBLIC WORKS DEPARTMENT  
 MARTINEZ, CALIFORNIA  
 STANDARD PLAN

**STD INLET/MANHOLE PLAN  
 GENERAL NOTES & DETAILS**

SCALE: NO SCALE  
 DATE: 3/14  
 DRAWN BY: H. MUSSEY  
 PLAN NO. **CD35**

NO	DATE	REVISION DESCRIPTION	BY	CHECKED BY: M. HOLLINGSWORTH

**CENTRAL CONTRA COSTA SANITARY DISTRICT  
STANDARD PLANS**

# CENTRAL CONTRA COSTA SANITARY DISTRICT MARTINEZ, CALIFORNIA

## RODDING INLET

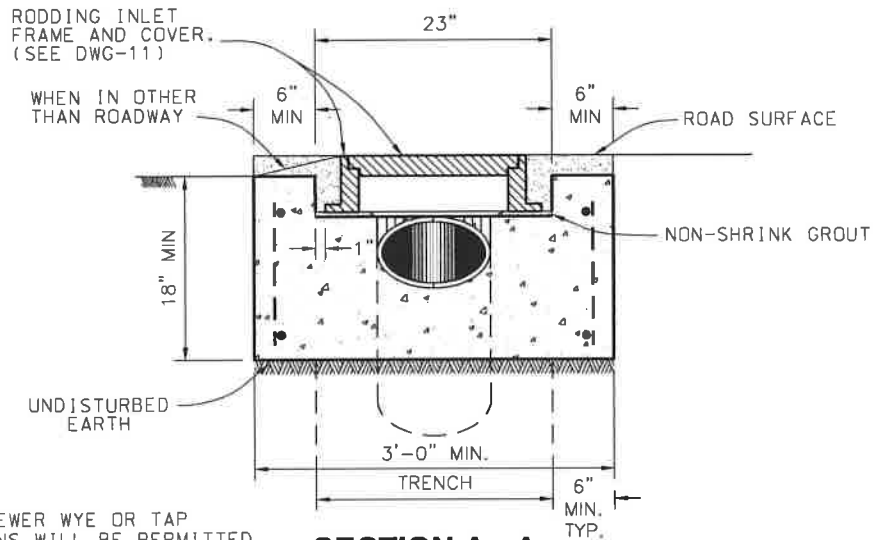

**SECTION A - A**

**NOTES:**

1. NO SIDE SEWER WYE OR TAP CONNECTIONS WILL BE PERMITTED IN RISER PIPE.
2. RISER PIPE SHALL BE THE SAME MATERIAL AS THE REST OF THE LINE & SHALL BE IN A VERTICAL PLANE.
3. NO LATERALS SHALL BE INSTALLED WITHIN 24" OF THE 45° FITTING.
4. SEE SECTION 5 - PLAN PREPARATION FOR STATIONING REQUIREMENTS OF A RODDING INLET STRUCTURE.
5. ALL STEEL REINFORCEMENT SHALL HAVE A MIN. OF 3" CONCRETE COVER.

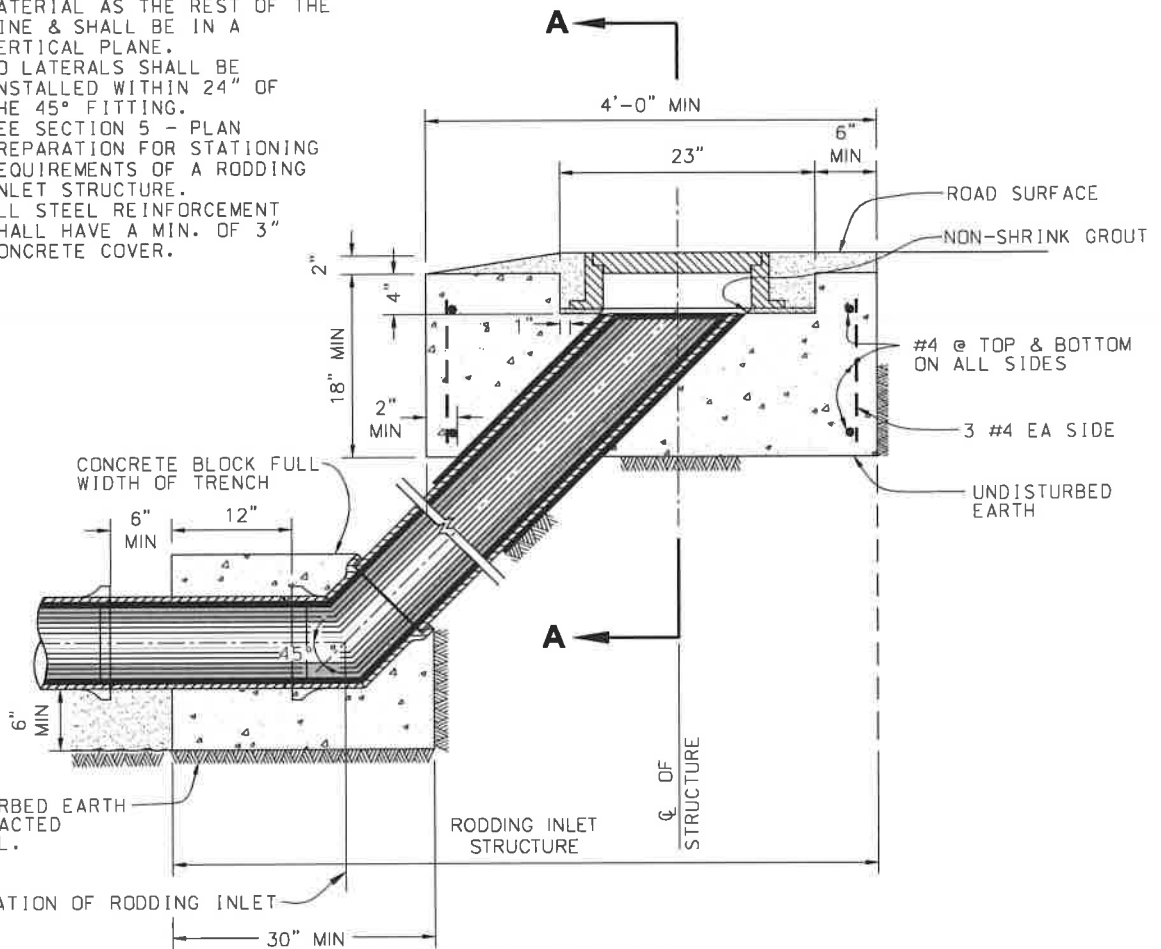

**VERTICAL SECTION**

08-Jul-2014 K:\Project\StandardSpecs\csl\sys10\_RoddingInlet.dwg

# CENTRAL CONTRA COSTA SANITARY DISTRICT MARTINEZ, CALIFORNIA

## RODDING INLET FRAME & COVER

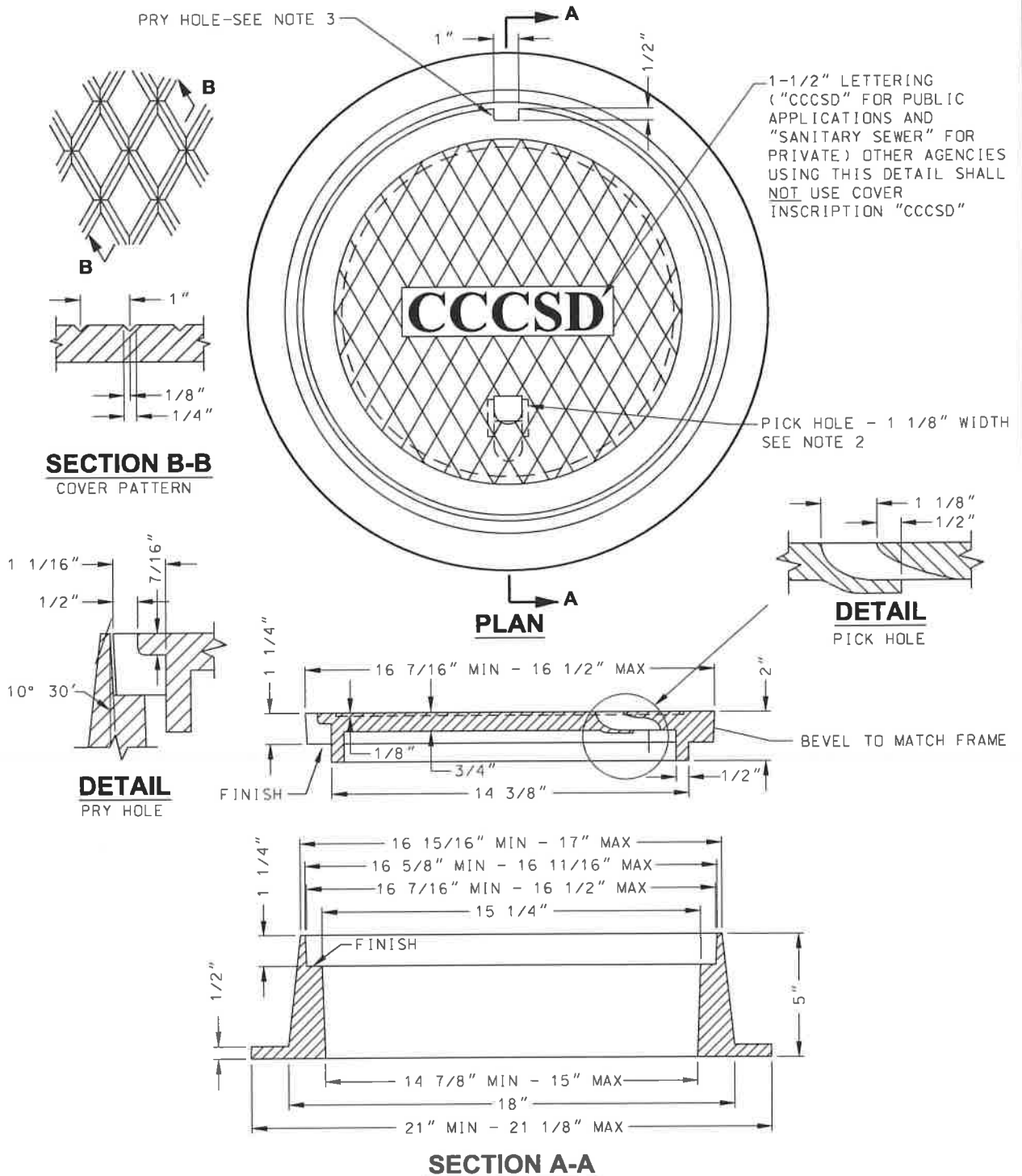

- NOTES:
1. COVER SHALL BE DESIGNED FOR HS-20 HIGHWAY LOADING.
  2. PICK HOLE SHALL BE OPEN AND FIT A STANDARD PICK.
  3. PRY HOLE SHALL BE LOCATED AT TOP CENTER OF THE RODDING INLET COVER AS SHOWN.



**CENTRAL CONTRA COSTA SANITARY DISTRICT  
MARTINEZ, CALIFORNIA**

**MANHOLE ADJUSTMENT TO FINISH GRADE**  
**PAVED AREAS**

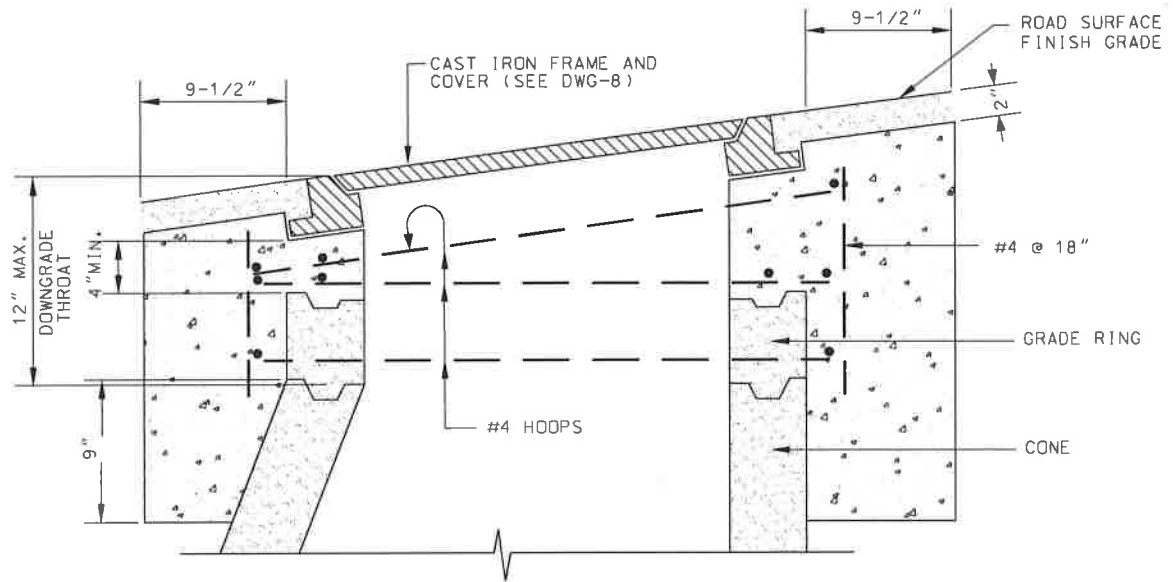

**GREATER THAN 13% GRADE**

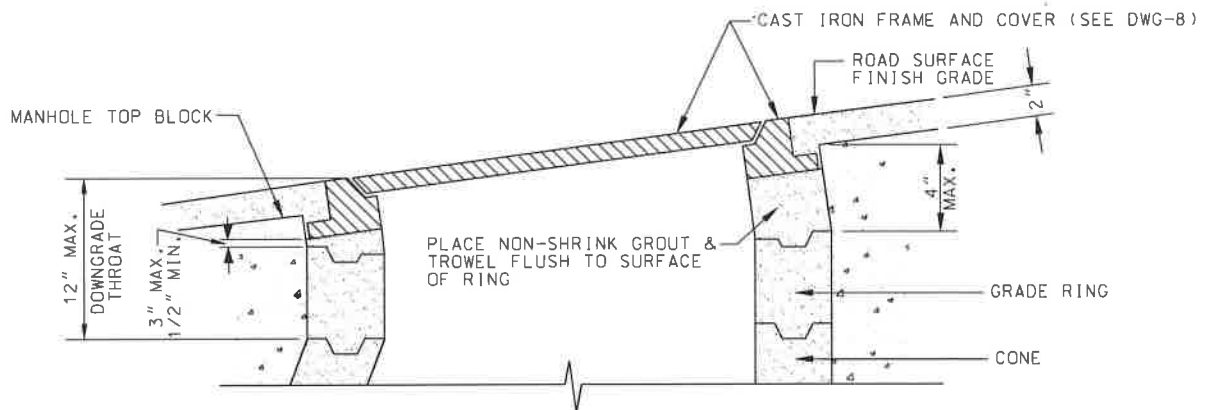

**NOTE:**

1. SEE DWG-1 FOR TOP BLOCK DETAILS

**13% GRADE OR LESS**

# VALVE BOX

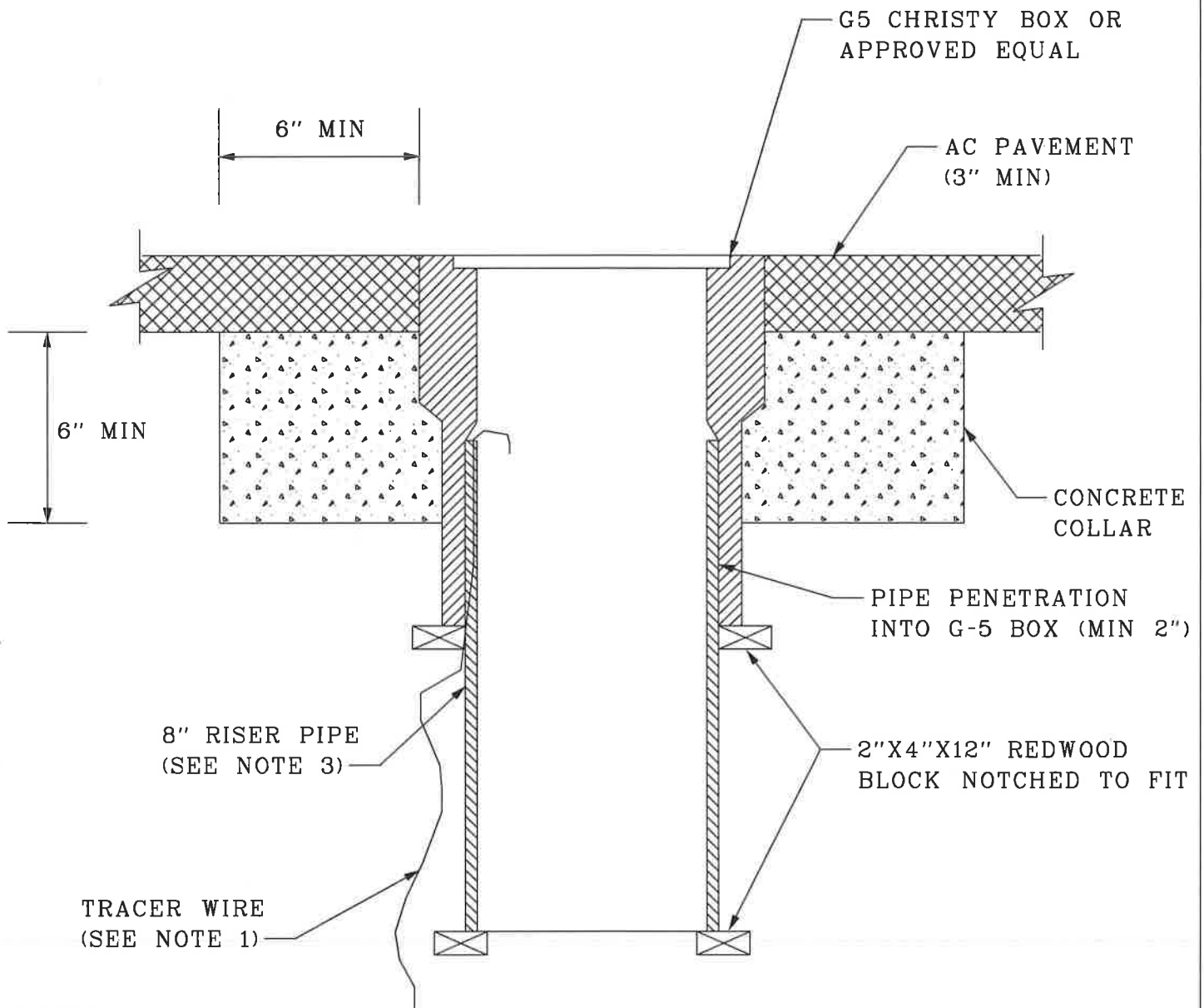

NOTES:

1. AC PAVEMENT TO COMPLY WITH STREET PAVEMENT REQUIREMENTS
2. FOR VALVE BOXES INSTALLED IN NON TRAFFIC AREAS, CONCRETE COLLAR SHALL BE EXTENDED TO FINISH GRADE AND SLOPED TO DRAIN AWAY FROM LID.
3. RISER PIPE TO BE ONE CONTINUOUS PIECE, APPROVED PVC CLASS 150, 200 OR STEEL PIPE WITH A MIN 10 GA WALL THICKNESS
4. IF TRACER WIRE IS OF SUFFICIENT LENGTH RE-ROUTE AS SHOWN

G5
VALVE BOX WITH CAST IRON TRAFFIC LID
NTS

## SIGN POST & ACCESSORIES

# The Anchor-Mate<sup>®</sup>

The Best Drivable Anchor in the World!

by **Ulti-Mate**<sup>®</sup>

The Ultimate Sign Support System

- No Deforming of Anchor during Installation
- No need to match Anchors and Sleeves
- Solid section below ground provides additional strength
- Two Piece Welded Design provides almost a full 1/4" top edge
- Quicker Easier Installation
- Perfect Hole Alignment

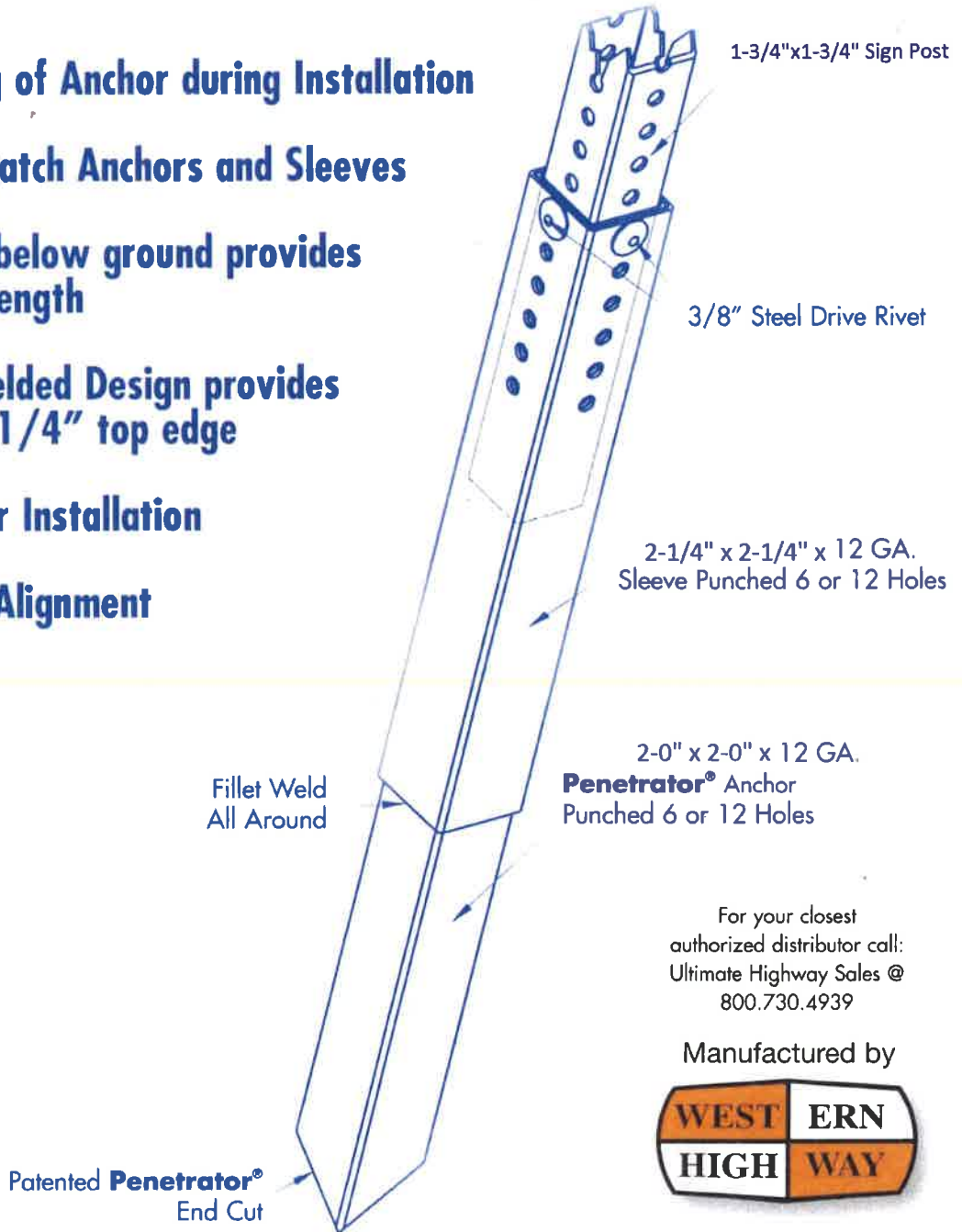

For your closest  
authorized distributor call:  
Ultimate Highway Sales @  
800.730.4939

Manufactured by



<http://www.westernhighway.com>  
E-mail: [whpsales@westernhighway.com](mailto:whpsales@westernhighway.com)

# Ulti-Mate<sup>®</sup>

The Ultimate Sign Support System

Traffic signs are the primary source of information for motorists. The biggest and brightest sign is only effective if the support it is mounted on keeps the sign in its intended position. Sign supports need to be strong,

versatile and cost effective. The Ulti-Mate<sup>®</sup> sign support system, approved by the Federal Highway Administration, is the most reliable, economical and easiest to install support system available.

## MATERIALS & SPECIFICATIONS

The Ulti-Mate sign support system is available in 12 and 14 gage steel complying with ASTM specification A653, hot dip galvanized conforming to coating designation G-140 for excellent corrosion prevention.

- Available with 7/16" holes on 1" centers on 2 or 4 sides (11.1mm on 25.4mm centers).
- The Ulti-Mate sign support system is completely compatible with all existing square posts.
- Mating tube sections allow for fast, safe ground level installations.

- Ground anchor posts allow for rapid replacement installations when necessary.
- Square tube sections provide superior resistance to wind and other forces over U-channel or round posts.
- The Ulti-Mate sign support system provides four flat surfaces for mounting signs in any direction and at any height without the need for additional hardware.
- FHWA approved as meeting safety requirements for sign supports.
- Custom sign support colors available on request.

## FHWA APPROVED INSTALLATIONS



### DIRECT INSTALLATION

The Ulti-Mate sign post can be installed directly into the ground using power equipment or a sledge-hammer with driving cap.



### EZ INSTALLATION

The Ulti-Mate 12 gage anchor system allows crews to work at ground level for fast installations and replacements. The Ulti-Mate anchor is installed directly into the ground, leaving 1 or 2 holes above grade level. The Ulti-Mate sign post slides into the anchor for safe and easy installations.



### HI-IMPACT INSTALLATION

The Ulti-Mate double 12 gage system is for areas that require frequent replacements due to damaged sign posts. This unique method utilizes a two-piece breakaway anchor that makes replacement work fast and safe.

For an easy to follow post-selection ordering guide, contact your local Ulti-Mate distributor.

## AVAILABLE PRODUCTS

Tube Size	English			Metric		
	Wall Thickness Gage	Wall Thickness Inches	Pounds Per Foot	Tube Size	Wall Thickness (mm)	Kilograms Per Meter
1.75 x 1.75	14	0.083	1.71	44.45 x 44.45	2.10	2.54
2.00 x 2.00	14	0.083	1.99	50.80 x 50.80	2.10	2.96
2.25 x 2.25	14	0.083	2.28	57.15 x 57.15	2.10	3.39
1.50 x 1.50	12	0.105	1.74	38.10 x 38.10	2.66	2.59
1.75 x 1.75	12	0.105	2.09	44.45 x 44.45	2.66	3.11
2.00 x 2.00	12	0.105	2.44	50.80 x 50.80	2.66	3.63
2.25 x 2.25	12	0.105	2.79	57.15 x 57.15	2.66	4.16
2.50 x 2.50	12	0.105	3.14	63.50 x 63.50	2.66	4.69

Distributed by:

For the name of your closest authorized distributor, call Ultimate Highway Sales at (800) 730-4939.

## Because you don't need all those holes...

Since the introduction of Ulti-Mate, the Ultimate Sign Support System, we have talked to highway engineers, designers and installers across the country on how to make the best better. The most common response was, "We don't need all those holes". The typical twelve foot post has 564 holes; in most cases only 2 holes are required. With that in mind, we are pleased to offer the Select Punch by Ulti-Mate. Choose the option that best serves your needs... No more unnecessary holes.

- Continuous punching in increments of six, on two or four sides and from either end.
- Custom drilling available to your exact location and hole size as required.
- Also available on all base posts including the Penetrator.
- Minimum of 25 posts per order.

Select Punch by Ulti-Mate. You talked and we listened. **The best just got better.**

**Ulti-Mate**<sup>®</sup>  
The Ultimate Sign Support System



1-3/4" x 1-3/4" x 120"  
14 GA Post

SELECT PUNCH  
ONE END - TWO

SELECT PUNCH  
BOTH ENDS - TWO SIDES

SELECT PUNCH  
CUSTOM DRILLED

SELECT PUNCH  
ONE END - FOUR

SELECT PUNCH  
BOTH ENDS - FOUR SIDES

## HARDWARE FLAT AND EXTRUDED BLADES

### MOUNTING COMPONENTS

<p><b>CONFIGURATION: End Mount</b></p> <p>Configuration includes nut and bolt set to hold sign in bracket</p> <p>Flat Blade Sign</p> <p>Mounting Straps</p> <p>End Mount Bracket (See chart below)</p> <p>Sign fully assembled on post.</p>	<p><b>CONFIGURATION: Single Mount Top of Pole</b></p> <p>Extruded Blade Sign</p> <p>Post Cap (See list below)</p> <p>Sign fully assembled on post.</p> <p>See note below for compatible posts</p> <p>Configuration includes set screws to hold sign in bracket and bracket onto post.</p>	<p><b>CONFIGURATION: Four-Way Mount Top of Pole</b></p> <p>Flat Blade Sign</p> <p>Sign to Sign Bracket</p> <p>Post Cap (See list below)</p> <p>Sign fully assembled on post.</p> <p>See list for below for compatible posts</p> <p>Configuration includes set screws to hold signs in bracket and bracket onto post.</p>
---------------------------------------------------------------------------------------------------------------------------------------------------------------------------------------------------------------------------------------------	-------------------------------------------------------------------------------------------------------------------------------------------------------------------------------------------------------------------------------------------------------------------------------------------	--------------------------------------------------------------------------------------------------------------------------------------------------------------------------------------------------------------------------------------------------------------------------------------------------------------------------



#### END MOUNT BRACKET

Blade street signs can be held on their ends with this bracket.

- EMB-6 for AX-6 or AF-6 signs
- EMB-6.75 for AX-6.75 or AF-6.75 signs
- EMB-9 for AX-9 or AF-9 signs



#### MOUNTING STRAP

Stainless Steel Strap/Clamp - inexpensive and convenient for mounting sign brackets and other uses. With a length of 32 inches, the clamp can accommodate poles up to 9 inches wide.

#### SIGN TO SIGN BRACKETS

Bracket allows two blade signs to be stack on top of one another.

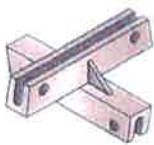

- 707XCS for AX-6 or AX-6.75 signs
- 808XCS for AX-9 signs
- 606FCS for AF-6 or AF-6.75 signs
- 808FCS for AF-9 signs

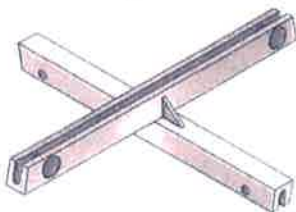

- 812XCS for AX-9 signs
- 812FCS for AF-9 signs





### POST CAPS AND POST INFORMATION

Post caps are recommended for "Single Top of Pole" or "Four-Way Top of Pole" configurations of blade street signs. Western Highway supplies post caps for the most common street sign posts. Use the following chart to see if your posts are compatible with our regularly available post caps.

<p>Cylindrical Post Caps</p>	<p><b>Fits 2" ID Diameter Post</b></p> <ul style="list-style-type: none"> <li>707X-2 for AX-6 or AX-6.75</li> <li>808X-2 for AX-9 signs</li> <li>606F-2 for AF-6 or AF-6.75 signs</li> <li>808F-2 for AF-9 signs</li> </ul>	<p><b>Fits 2-1/2" ID Diameter Post</b></p> <ul style="list-style-type: none"> <li>707X-2.5 for AX-6 or AX-6.75</li> <li>808X-2.5 for AX-9 signs</li> <li>606F-2.5 for AF-6 or AF-6.75 signs</li> <li>808F-2.5 for AF-9 signs</li> </ul>
<p>Square Post Cap</p>	<p><b>Fits Square Tube Post</b></p> <ul style="list-style-type: none"> <li>850X for AX-6, AX-6.75 or AX-9 signs</li> <li>850F for AF-6, AF-6.75 or AF-9 signs</li> </ul>	<p>Other post caps are available. Please call us to confirm inventory.</p>
<p>U-Channel Post Cap</p>	<p><b>Fits U-Channel Post</b></p> <ul style="list-style-type: none"> <li>707XU for AX-6 or AX-6.75 signs</li> <li>808XU for AX-9 signs</li> <li>606FU for AF-6 or AF-6.75 signs</li> <li>808FU for AF-9 signs</li> </ul>	



# SIGN POST

 <p><b>H21-DP</b> DELINEATOR POSTS HOT DIPPED GALVANIZED OR BAKED ENAMEL GREEN 5 ft. 6 ft. 1.12 #in 30 - 3/8" holes on 1" centers. Light weight but strong. Ideal for Delineators, or marking utility lines.</p>	 <p><b>H21-GP</b> 5 ft., 6 ft. GUIDE POSTS (FOR MTG. TARGET PLATES) <b>H21-GP</b> 40 Inch (for mig. Type "K" Plates) California Spec. Flanges slotted ends pointed</p>	<p><b>PIPE POST</b></p>  <p><b>H21-RP2-12</b> <b>H21-RP2.5-12</b> <b>H21-RP2</b> <b>H21-RP2.5</b> GALVANIZED STEEL PIPE POSTS Schedule 40 steel pipe 2 inch and 2 1/2 inch I.D. 10 1/2 ft. and 12 ft. long <b>IN STOCK</b></p>	<p><b>"U" CHANNEL POSTS</b> HOT DIPPED GALVANIZED OR BAKED ENAMEL GREEN</p>  <p><b>H21-SP</b> SIGN POSTS 6 ft. 7 ft. 8 ft. 9 ft. 10 ft. 11 ft. 12 ft. 2 lb per foot</p> <p><small>*Other lengths on special order / Hot rolled, high carbon, rail steel, 3/8" holes punched on 1" centers, full length. Bottom pointed. High carbon steel is recommended because of resist bending. Meets &amp; exceeds California State specifications.</small></p>
-----------------------------------------------------------------------------------------------------------------------------------------------------------------------------------------------------------------------------------------------------------------------------------------------------------------------	---------------------------------------------------------------------------------------------------------------------------------------------------------------------------------------------------------------------------------------------------------------------	-------------------------------------------------------------------------------------------------------------------------------------------------------------------------------------------------------------------------------------------------------------------------------------------------------------------------------------------------	--------------------------------------------------------------------------------------------------------------------------------------------------------------------------------------------------------------------------------------------------------------------------------------------------------------------------------------------------------------------------------------------------------------------------------------------------------------------------------------------------------------------------------------------------------------------

## Uti-Mate<sup>®</sup> The Ultimate Sign Support System



**DIRECT INSTALLATION**  
The Uti-mate sign post can be installed directly into the ground using power equipment or a sledgehammer with drive cap.



**EZ INSTALLATION**  
The Uti-mate 12 gage anchor system allows crews to work at ground level for fast installations and replacements. The Uti-mate anchor is installed directly into the ground, leaving 1 or 2 holes above grade level. The Uti-mate sign post slides into the anchor for safe and easy installations.



**HI-IMPACT INSTALLATION**  
The Uti-mate double 12 gage system is for areas that require frequent replacements due to damaged sign posts. This unique method utilizes a two-piece breakaway anchor that makes replacement work fast and safe.

Tube Size	English			Tube Size	Metric	
	Gage	Inches	Pounds Per Foot		Wall Thickness (mm)	Kilograms Per Meter
1.75 x 1.75	14	0.083	1.71	44.45 x 44.45	2.10	2.54
2.00 x 2.00	14	0.083	1.99	50.80 x 50.80	2.10	2.96
2.25 x 2.25	14	0.083	2.28	57.15 x 57.15	2.10	3.39
1.50 x 1.50	12	0.105	<b>1.74</b>	38.10 x 38.10	2.66	2.59
1.75 x 1.75	<b>12</b>	0.105	2.09	<b>44.45 x 44.45</b>	2.66	<b>3.11</b>
2.00 x 2.00	12	0.105	2.44	50.80 x 50.80	2.66	3.83
2.25 x 2.25	12	0.105	2.79	57.15 x 57.15	2.66	<b>4.16</b>
2.50 x 2.50	12	0.105	3.14	63.50 x 63.50	2.66	4.59

See Separate Literature

# SIGN POST ACCESSORIES



**H25-4A**  
DETACHABLE  
POST PULLER ONLY  
(any shape post)  
Must be used with Jack.

**H25-7**  
POST PULLER JACK  
ONLY  
Includes Base & Handle.

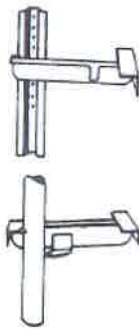

**H25-6**  
Self Locking  
U-Post Step

**H25-6A**  
Self Locking  
2" Pipe Step



**H25-8**  
POST DRIVER  
For Driving U Channel  
Sign Posts.  
38 lb.



**H26-SP**  
1 1/2" x 48 PIPE ONLY  
Painted Black

Use H5 Spacer and H6-2.5  
Bolts for mounting signs to  
above.



**H26-20B**  
20 lb. Base Only  
**H26-30B**  
30 lb. Base Only  
**H26-40B**  
40 lb. Base Only

5/16" flat steel plate  
base. Painted black.



**ULTI-MATE STOP**

TO BE USED FOR  
TEMPORARY TRAFFIC  
CONTROL SITUATIONS.

See separate literature for  
complete information.



**H21-SPDC**  
MANUAL DRIVE CAP  
For U-Channel

**H21-SPPDC**  
POWER DRIVE CAP  
& 7/8" SHANK  
For U-Channel

**UM-MDC175**  
MANUAL DRIVE CAP  
For 1 3/4" anchor posts

**UM-MDC200**  
MANUAL DRIVE CAP  
For 2" anchor posts

**UM-MDC225**  
MANUAL DRIVE CAP  
For 2 1/4" anchor posts

**UM-MDC250**  
MANUAL DRIVE CAP  
For 2 1/2" anchor posts



**UM-PDCS7/8-325**  
POWER DRIVE SHANK  
7/8" x 3 1/4"

**UM-PDCS7/8-425**  
POWER DRIVE SHANK  
7/8" x 4 1/4"

**UM-PDCS1-425**  
POWER DRIVE SHANK  
1" x 4 1/4"

**UM-PDCS1 1/8-6**  
POWER DRIVE SHANK  
1 1/8" x 6"

**UM-PDCS1 1/4-6**  
POWER DRIVE SHANK  
1 1/4" x 6"

**UM-PDCS1 1/2-6**  
POWER DRIVE SHANK  
1 1/2" x 6"

**UM-PDCS1 3/4-6**  
POWER DRIVE SHANK  
1 3/4" x 6"

**UM-PDCS1 1-6**  
POWER DRIVE SHANK  
1" x 6"

**UM-PDCS1 1 1/2-6**  
POWER DRIVE SHANK  
1 1/2" x 6"

**UM-PDCS1 1 3/4-6**  
POWER DRIVE SHANK  
1 3/4" x 6"

**UM-PDCS1 2-6**  
POWER DRIVE SHANK  
2" x 6"

**UM-PDCS1 2 1/2-6**  
POWER DRIVE SHANK  
2 1/2" x 6"

**UM-PDCS1 3-6**  
POWER DRIVE SHANK  
3" x 6"

**UM-PDCS1 3 1/2-6**  
POWER DRIVE SHANK  
3 1/2" x 6"

**UM-PDCS1 4-6**  
POWER DRIVE SHANK  
4" x 6"

**UM-PDCS1 4 1/2-6**  
POWER DRIVE SHANK  
4 1/2" x 6"

**UM-PDCS1 5-6**  
POWER DRIVE SHANK  
5" x 6"

**UM-PDCS1 5 1/2-6**  
POWER DRIVE SHANK  
5 1/2" x 6"

**UM-PDCS1 6-6**  
POWER DRIVE SHANK  
6" x 6"

**UM-PDCS1 6 1/2-6**  
POWER DRIVE SHANK  
6 1/2" x 6"

**UM-PDCS1 7-6**  
POWER DRIVE SHANK  
7" x 6"



**UM-PDC175**  
POWER DRIVE CAP  
For 1 3/4" anchor posts

**UM-PDC200**  
POWER DRIVE CAP  
For 2" anchor posts

**UM-PDC225**  
POWER DRIVE CAP  
For 2 1/4" anchor posts

**UM-PDC250**  
POWER DRIVE CAP  
For 2 1/2" anchor posts

**UM-PDC275**  
POWER DRIVE CAP  
For 2 3/4" anchor posts

**UM-PDC300**  
POWER DRIVE CAP  
For 3" anchor posts

**UM-PDC325**  
POWER DRIVE CAP  
For 3 1/4" anchor posts

**UM-PDC350**  
POWER DRIVE CAP  
For 3 1/2" anchor posts

**UM-PDC375**  
POWER DRIVE CAP  
For 3 3/4" anchor posts

**UM-PDC400**  
POWER DRIVE CAP  
For 4" anchor posts

**UM-PDC425**  
POWER DRIVE CAP  
For 4 1/4" anchor posts

**UM-PDC450**  
POWER DRIVE CAP  
For 4 1/2" anchor posts

**UM-PDC475**  
POWER DRIVE CAP  
For 4 3/4" anchor posts

**UM-PDC500**  
POWER DRIVE CAP  
For 5" anchor posts

**UM-PDC525**  
POWER DRIVE CAP  
For 5 1/4" anchor posts

**UM-PDC550**  
POWER DRIVE CAP  
For 5 1/2" anchor posts

**UM-PDC575**  
POWER DRIVE CAP  
For 5 3/4" anchor posts



**STREET NAME  
SIGN  
HARDWARE**

WE MANUFACTURE A COMPLETE LINE OF STREET  
NAME SIGN MOUNTING HARDWARE. LOOK FOR IT  
IN THE STREET NAME SIGN SECTION OF YOUR  
WESTERN HIGHWAY PRODUCTS CATALOG.

10650 FERN AVENUE, STANTON, CALIFORNIA 90680

(714) 761-4811 (800) 479-3783 FAX (714) 952-2118

<http://www.westernhighway.com>

E-mail [whpsales@westernhighway.com](mailto:whpsales@westernhighway.com)

# SIGN MOUNTING HARDWARE

	<p><b>H1-SL</b> STRAP-ON BRACKET (Straight Leg) Extra Heavy 1/8" Steel Hot dipped galv. with 5/16" tapped hole. Slotted for 3/4" Strap. Mounting Bolt not included.</p> <p><b>H1-SLSS</b> STAINLESS STEEL BRACKET Includes Mounting Bolt</p>	<p><b>H6-STB</b> SEAL-TITE BOLT 5/16" X 1/2" bolt with Neoprene washer for mounting Signs with tapped brackets or pipe.</p>
	<p><b>H2-FL</b> STRAP-ON BRACKET (Flared Leg) For bending to large poles Extra Heavy 1/8" Steel, Hot dipped galv. with 5/16" tapped hole. Slotted for 3/4" Strap.</p> <p><b>H2-FLSS</b> STAINLESS STEEL BRACKET Includes Mounting Bolt.</p>	<p><b>H6-TPBKEY</b> KEY WRENCH For tamper proof bolt</p> <p><b>H6-TPDR</b> RATCHET DRIVER For tamper proof bolt</p> <p><b>H6-TP</b> TAMPER PROOF BOLT 5/16" X 1/2" special spanner head bolt. Use same as H6-STB bolt.</p>
	<p><b>H3-CLB</b> STRAP-ON BRACKET CANTILEVER Heavy Gauge Aluminum Use one for each sign hole For mounting double face Signs. Slotted for 3/4" strap and punched for 5/16" bolts.</p>	<p><b>H6-VGNG</b> For Galv. Bolt <b>H6-VGNP</b> For Plated Bolt VANDERLIND-NUT Tamper Proof Nut for Sign Mounting Call Western Highway for information on this unique, easily installed nut that cuts sign losses.</p>
	<p><b>H4-D-007</b> STRAP-ON L-MOUNT BRKT. Stainless Steel Double holes for mounting long signs. May be used back to back in pairs for extra rigid cantilever mounting. Slotted for 3/4" Strap.</p>	<p><b>H6-2.5 BG</b> 2 1/2" - Galv. <b>H6-2.5 BP</b> 2 1/2" - Plated BUTTON THEFT PROOF BOLT When this button head bolt is used with nut H6-VGN above, theft is almost impossible. 5/16" Diameter. Available in both galvanized and plated.</p> <p><b>H6-4.5 CB</b> 4 1/2" Plated Carriage Bolt includes adaptor washer. Washer can be sold as separate item.</p>
	<p><b>H5</b> BOLT-ON SPACER Galv. Channel Iron 1 1/2" x 1 1/2" x 1/8" Provides flat mounting surface when bolting sign to any size pipe to prevent wobble.</p>	<p><b>H6-23</b> SIGN MTG. HDWR. For U Channel Posts. Aluminum spacer 3 1/2" x 2 1/2", 5/16" x 2 1/2" Bolt, Washer and Nut.</p> <p><b>H6-24</b> GUIDE PLATE MTG. HDWR. 1/4 X 1/2" Bolt, Washer and Lock Nut (8 sets req'd per Guide Marker).</p>

# SIGN MOUNTING HARDWARE



**HWSSC**  
**STAINLESS STEEL-CLAMP**  
 Inexpensive and convenient for mounting sign brackets and other uses. 32" long fits 2" to 9" diameter pipe poles.



**H14-C130**  
**3/4" STRAPPING TAPE**  
 015 Stainless Steel  
 200 Ft. Roll



**H9-2**  
**H9-2.5**  
**CLAMP ON U-BRACKETS**  
 (Single Bracket)  
 Includes steel zinc coated U bolt with nuts and cast aluminum bracket. Sign fastening bolt not included.  
 (Use H6-STB or H6-TP)  
 Fits 2" and 2 1/2" I.D. standard pipe, eliminates strapping or drilling holes



**H14-C153**  
**3/4" STRAPPING TAPE**  
 .020 Stainless Steel  
 200 Ft. Roll

**H14-C156**  
**VALUE CLIP**  
 100 per Box.



**H10-1** (3/16 x 1 x 36")  
**SIGN BRACE (Galv.)**  
 To fit 4 x 4 posts  
**H10-2** (3/16 x 1 x 37 1/4")  
 To fit 4 x 6 posts  
**H10-3 SHG**  
**HEX HEAD BRACE BOLT**  
 5/16" x 4 1/2" Includes nut & washer  
**H10-5 SHG**  
**HEX HEAD BRACE BOLT**  
 5/16" x 6 1/2" Includes nut & washer  
**H10-8 SHG**  
**HEX HEAD BRACE BOLT**  
 5/16" x 8 1/2" Includes nut & washer

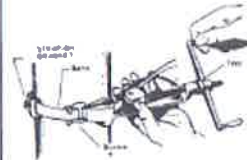

**H18-C001**  
**BANDING TOOL**  
 For use with any size Banding or Strapping Tapes.



**H11-C203** 3/8"  
**H11-C204** 1/2"  
**H11-C205** 5/8"  
**H11-C206** 3/4"  
**HEAVY DUTY**  
**BANDING TAPE**  
 303 Stainless Steel 100 Ft. Roll



**H19-HP2**  
**HAND PLIER RIVETING TOOL**  
 For self-setting rivets. Complete with 4 size Heads - 3/32, 1/8, 5/32, 3/16.



**H20-AB65A**  
**3/16" SELF-SETTING RIVETS**  
 For fastening C.M. Nut. Buttons with Hand Plier. 100 per Box.



**H20-16**  
**1/4" x 7/8" POP RIVET**  
 100 per Box.

**H20-26**  
**CHERRY-MATE FASTENER**  
 1/4" X 1 3/8" POP RIVETS  
 A convenient way to mount signs on the H21-SP sign posts.  
 100 per Box.



**H16-C253** 3/8"  
**H16-C254** 1/2"  
**H16-C255** 5/8"  
**H16-C256** 3/4"  
**HEAVY DUTY**  
**RUCKLES**  
 Stainless Steel 100 per Box

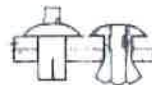

**H20-316** 3/16" x 8/18"  
**DRIVE RIVETS**  
 For fastening C.M. Nut Buttons with Hammer.

**H20-38** 3/8" x 1/2"  
 For sign mounting. 100 per box.

## **APPENDIX C**

**ROAD CLOSURE SAMPLE LETTER**

**ROAD CLOSURE SAMPLE SIGN**

**RE-NOTIFICATION ROAD CLOSURE SAMPLE SIGN**



City Council

Mike Anderson, Mayor  
Don Tatzin, Vice Mayor  
Cameron Burks, Council Member  
Mark Mitchell, Council Member  
Ivor Samson, Council Member

---

## NOTICE OF ROAD CLOSURE

XXXXXX, 2017

Subject: City of Lafayette 2017 Road Rehabilitation Project, Project Number 014-9711

Dear Residents:

XXXXXXXXXXXXX will be starting the roadway reconstruction and paving phase of work starting XXXXXX, 2017 on **Sample Street**. During this phase of work the street will be closed between 8:30 a.m. and 4:30 p.m., and parking on the shoulder of the road will be prohibited from 8:00 am. to 5:00 pm. You may park outside the closure on surrounding streets in any legal parking space to have access to your vehicle during the road closure hours. If the contractor allows vehicle traffic into or out of the closure it will be at their discretion and dependent on the construction activity and safety of the access. Please note that emergency vehicles will be provided access at all times.

The contractor's schedule calls for the following road closure dates:

**Sample Street**

XXXXXXXXXX – XXXXXXXX – Pulverize, grade, & cement treat the roadway

(note no work will be done on the weekend)

XXXXXXXXXX, 2017 – Paving Base Lift of asphalt

XXXXXXXXXX, 2017 – Paving the final layer of asphalt

Changes in the work dates will be posted on or near the project information sign at the entrance to your street. In addition, weekly updates for the project schedule will be posted on the City's web site at <http://www.ci.lafayette.ca.us> Select "Public Works & Construction" in the quick links section of the home page; then select the link for this project under "City Construction Projects," then select the 2017 Road Rehabilitation Project.

The city and the contractor are anxious to complete this project with minimum delay and inconvenience to you. While the work is in progress, please lend us your cooperation and extra patience and be alert to equipment, workers, and traffic control.

During the construction, questions regarding the work may be directed to XXXXXX, Site Superintendent for XXXXXX at (XXX) XXX-XXXX. I may be reached at (925) 299-3247. Again, your patience and cooperation are very much appreciated.

Sincerely,

Matt Luttrupp  
Senior Engineer

# **Sample Street**

**Road Reconstruction**

**ROAD CLOSED**

**Wed 9/23 – Fri 9/25**

**Mon 9/28 – Tue. 9/29**

**Mon 10/5 – Tues 10/6**

**8:30 am to 4:30 pm**

**UPDATE**

**Sample Street**

**Road Reconstruction**

**ROAD CLOSED**

**Mon 9/21 – Fri 9/25**

**Wed 9/30 – Thurs 10/1**

**8:30 am to 4:30 pm**



**APPENDIX D**

**EBMUD TEMPORARY CONSTRUCTION PERMIT  
AND  
CONTRACTORS POTHOLE LOG FORM**

File No. \_\_\_\_\_

**APPLICATION FOR USE OF EBMUD PROPERTY  
OR REQUEST FOR INFORMATION**

Please complete this form with as much information as possible. Incomplete applications cannot be processed and will result in delays in the District's response time. Please return this form with two insurance documents and appropriate fees to: **EBMUD, 1804 W. MAIN STREET, STOCKTON, CA 95203.**

APPLICANT NAME: \_\_\_\_\_  
(please print)

FIRM (if applicable): \_\_\_\_\_

ADDRESS: \_\_\_\_\_

PHONE: Residence: \_\_\_\_\_ Business: \_\_\_\_\_

EMAIL ADDRESS (can expedite application process): \_\_\_\_\_

ADDRESS/LOCATION OF EBMUD PROPERTY (Attach map or identify with Assessor's Parcel Number or Aqueduct Station Number): Brookdale Court near Hope Lane

USE REQUESTED: (Give a complete description of your project. Include type, size and weights of equipment and vehicles. Attach an extra sheet, if necessary):

Reconstruction of the existing paved surface and spot location removal and replacement of curb and gutter improvements. Reconstruction shall consist of pulverizing the existing asphalt and underlying materials to a depth of 15-inches, excavation of approximately 4-inches of the pulverized material, cement treating and compacting 8-inches of the remaining material followed by the placement of 4-inches of hot mix asphalt. No vibratory compaction equipment will be used. A summary of the equipment to be used and associated vehicle weights is attached.

ARE OTHER COUNTY/CITY APPROVALS OR PERMITS REQUIRED? YES  NO   
If yes, please give details.

\_\_\_\_\_  
The project is a City of Lafayette road reconstruction project.

Under the California Environmental Quality Act (CEQA) your request to use EBMUD property may be considered a project which requires completion of environmental documentation. Has any type of environment documentation (Negative Declaration or Environmental Impact Report) already been completed for this project? If so, please submit a copy of that documentation, highlighting the area(s) which specifically deal with your requested use of EBMUD property.

ADDITIONAL COMMENTS/REMARKS: The City of Lafayette prepared a Negative Declaration for this project. Please see attached.

NOTE: If your project involves or requires any soils studies, engineering plans or environmental documentation, these documents must be attached in duplicate with this application.



# CERTIFICATE OF COMMERCIAL GENERAL AND AUTO LIABILITY INSURANCE

**THIS IS TO CERTIFY TO:**

East Bay Municipal Utility District (EBMUD)  
 Department: Aqueduct Section  
 Street Address: \_\_\_\_\_  
 Mailing Address: 1804 West Main Street  
 City, State, Zip: Stockton, CA 95203

**THE FOLLOWING DESCRIBED POLICY HAS BEEN ISSUED TO:**

District Contract Number: \_\_\_\_\_  
 Insured: \_\_\_\_\_  
 Address: \_\_\_\_\_

**LOCATION AND DESCRIPTION OF PROJECT/AGREEMENT:**

**TYPE OF INSURANCE:** Commercial General and Automobile Liability Coverage/Endorsements as required by agreement.

**LIMITS OF LIABILITY:**

(MINIMUM) \$2,000,000/Occurrence, Bodily Injury, Property Damage-General Liability  
 \$2,000,000/Occurrence, Bodily Injury, Property Damage-Auto Liability

**SELF INSURED RETENTION (\$):** (Auto) \_\_\_\_\_ (GL) \_\_\_\_\_ (if applicable)  
 Aggregate Limits (AUTO) \_\_\_\_\_ (GL) \_\_\_\_\_ (if applicable)

**INSURANCE COMPANY(IES):** (Auto) \_\_\_\_\_ (GL) \_\_\_\_\_

**POLICY NUMBER(S):** (Auto) \_\_\_\_\_ (GL) \_\_\_\_\_

**POLICY TERM:** From: (Auto) \_\_\_\_\_ (GL) \_\_\_\_\_ To: (Auto) \_\_\_\_\_ (GL) \_\_\_\_\_

**THE FOLLOWING COVERAGES OR ENDORSEMENTS ARE INCLUDED IN THE POLICY(IES):**

1.  The District, its Directors, Officers and Employees are *Additional Insureds* in the policy(ies) as to work being performed under this agreement. ENDORSEMENT NO. \_\_\_\_\_
2.  The coverage is *Primary and non-contributory* to any other applicable insurance carried by the District.
3.  The policy(ies) covers *contractual liability*.
4.  The policy(ies) is written on an *occurrence* basis.
5.  The policy(ies) covers District's Property in Consultant's care, custody and control.
6.  The policy(ies) covers *personal injury* (libel, slander, and wrongful entry and eviction) liability.
7.  The policy(ies) covers *explosion, collapse, and underground* hazards.
8.  The policy(ies) covers *products and completed operations*.
9.  The policy(ies) covers the use of *owned, non-owned* and hired automobiles.
10.  The policy(ies) and/or a separate pollution liability policy(ies) shall cover pollution liability for claims related to the release or the threatened release of pollutants into the environment arising out of or resulting from Consultant's performance under this agreement.
11.  The policy(ies) will not be canceled nor the above coverages/endorsements reduced without 30 days written notice to East Bay Municipal Utility District at the address above.

**IT IS HEREBY CERTIFIED that the above policies provide liability insurance as required by the agreement between the East Bay Municipal Utility District and the insured.**

Signed \_\_\_\_\_  
 Address \_\_\_\_\_

Firm \_\_\_\_\_  
 Date \_\_\_\_\_  
 Phone \_\_\_\_\_



# CERTIFICATE OF WORKERS' COMPENSATION INSURANCE

**THIS IS TO CERTIFY TO:**

East Bay Municipal Utility District (EBMUD)  
 Department: Aqueduct Section  
 Street Address:  
 Mailing Address: 1804 West Main Street  
 City, State, Zip: Stockton, CA 95203

**THE FOLLOWING DESCRIBED POLICY HAS BEEN ISSUED TO:**

District Purchase Order  
 Number:

(Completed by EBMUD)

Insured:

Address:

**LOCATION AND DESCRIPTION OF PROJECT/AGREEMENT:**

**TYPE OF INSURANCE:** Workers' Compensation Insurance as required by California State Law.

The Workers' Compensation Carrier agrees to waive rights of recovery against District regardless of the applicability of any insurance proceeds, and to require all indemnifying parties to do likewise. All Workers' Compensation coverage maintained or procured by permit Holder shall be endorsed to delete the subrogation condition as to District, or must specifically allow the named insured to waive subrogation prior to a loss.

**INSURANCE COMPANY:**

**POLICY NUMBER:**

**POLICY TERM:**

From:

To:

**The policy will not be canceled nor the above coverage reduced without 30 days written notice to East Bay Municipal Utility District at the address above.**

**IT IS HEREBY CERTIFIED the above policy provides insurance as required by the agreement between East Bay Municipal Utility District at the Insured.**

Signed:

Date:

Firm:

E-mail

Address:

Phone:

"This certificate or verification of insurance is not an insurance policy and does not amend, extend, or alter the coverage afforded by the policies listed herein. Notwithstanding any requirement, term or conditions of any contract or other document with respect to which this certificate or verification or insurance may be issued or may pertain, the insurance afforded by the policies described herein is subject to all the terms, exclusions, and conditions of the policies."

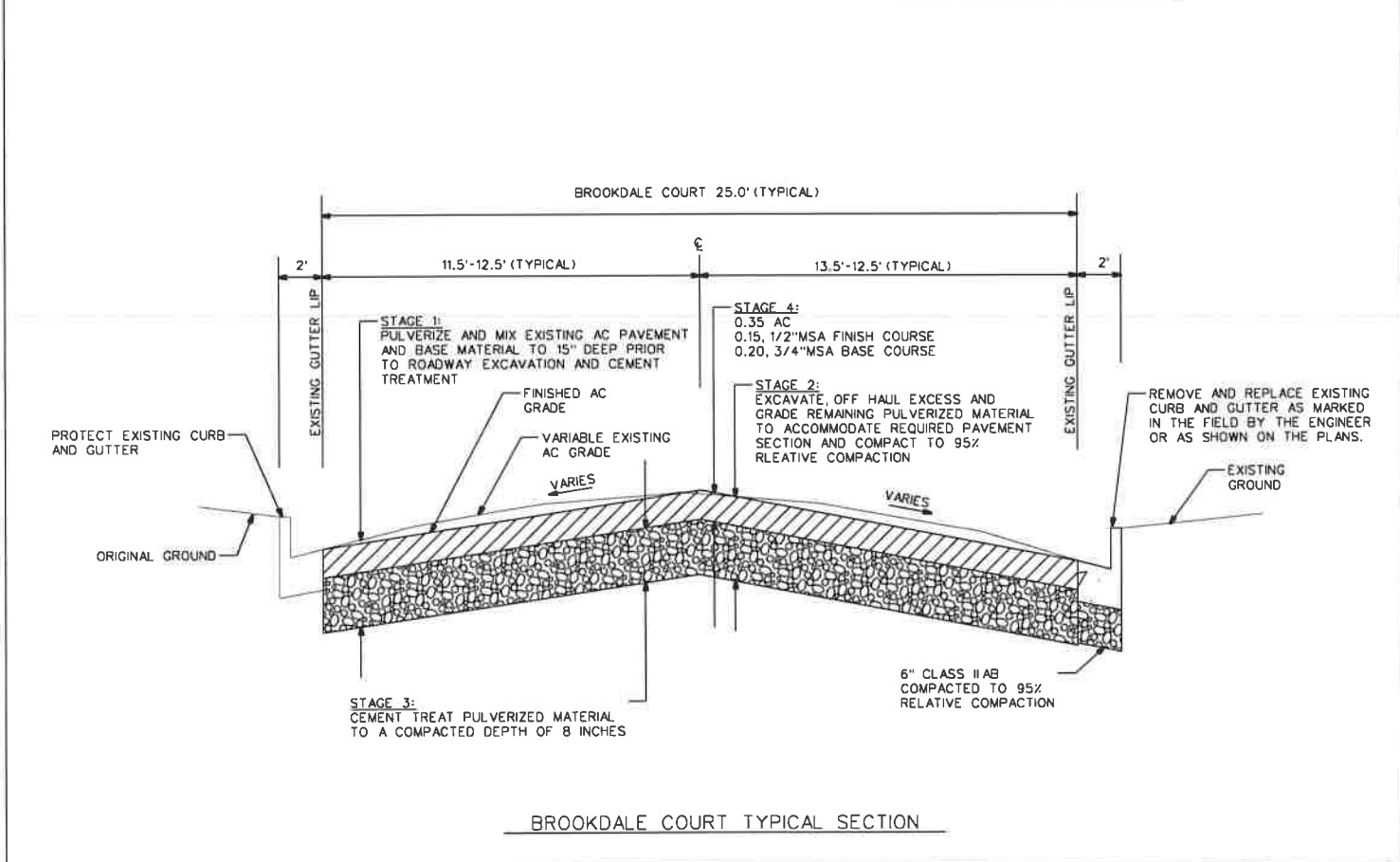
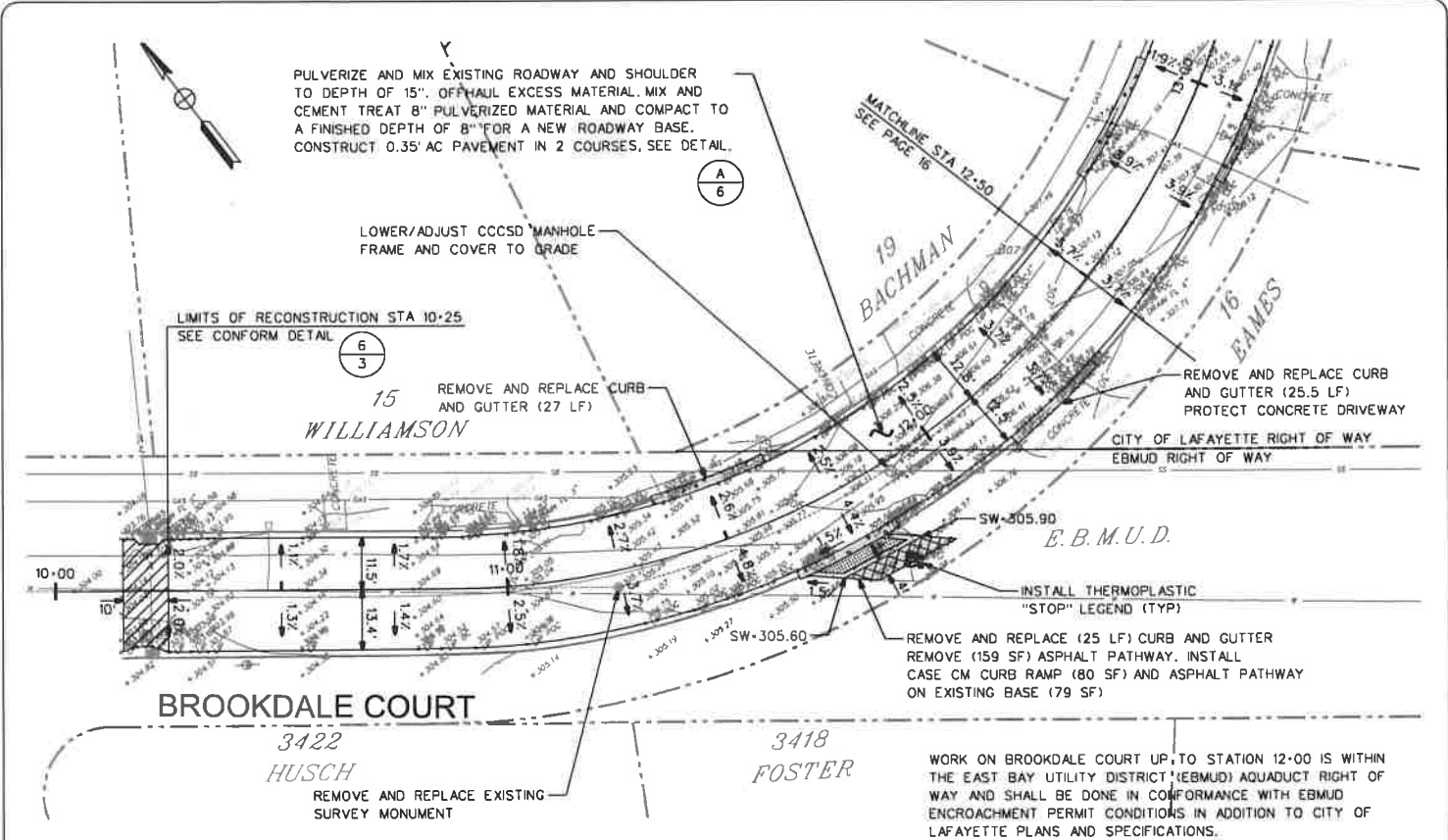

BROOKDALE COURT TYPICAL SECTION

CITY OF LAFAYETTE  
PROJECT NO. 014-9711

2017 ROAD REHABILITATION PROJECT  
CONTRA COSTA COUNTY CALIFORNIA

BROOKDALE COURT  
CONSTRUCTION IN  
AQUEDUCT ZONE

# Temporary Construction Permit

For Property Owned by  
**East Bay Municipal Utility District**  
July 19 2016

**WATER SUPPLY DIVISION  
AQUEDUCT SECTION**

**PERMITTEE:** ABC Paving  
7985 Showe Road  
Martinez, CA 94553  
Attn: John Smith

**PHONE NO.:** 555-55-5555

**EMAIL:** sender@abcpaving.com

**PROJECT:** Grind and pave roadway at two locations

**DESCRIPTION OF USE/WORK TO BE PERFORMED:**

Temporary access to EBMUD's aqueduct right of way for grinding and paving work associated with road maintenance project for City of Antioch. Work at two locations; Lone Tree Way & Hillcrest Avenue and Somersville Road and Buchanan Road

Station P3128 – P3130

Station P3420 – P3422

**TERM OF PERMIT:** 7/19/16 – 8/5/16

**FEE:** \$100, payable to East Bay Municipal Utility District

**EBMUD CONTACT:** Bill Pulsifer, Assistant Superintendent  
1804 West Main Street, Stockton, CA 95203

**Contact Info.:** (209) 946-8009, bill.pulsifer@ebmud.com

Permission may be given subject to the following terms and conditions:

1. Permittee's work will in no way interfere with the operations of EBMUD, and Permittee will not damage the land, aqueducts or other property of EBMUD. Permittee will promptly restore, repair or reimburse EBMUD for any such damage.

**Temporary Construction Permit**

**Page 2**

2. It is understood by Permittee that this permission will be given solely for the purpose and for the period of time noted above.
3. It is understood by Permittee that this permission is subject to all existing rights, rights of way, reservations and easements by whomsoever held in and to the real property above described.
4. Contractor expressly agrees to indemnify, defend and hold harmless EBMUD, its directors, officers, and employees from and against any and all loss, liability, expense, claims, costs, suits, and damages, including attorney's fees, arising out of Contractor's operation or performance under this Permit, including all costs, claims, and damages (including property and personal injury) arising out of any hazardous substances, hazardous materials or hazardous wastes (including petroleum) on the EBMUD property caused, uncovered, released or excavated as a result of Contractor's construction, reconstruction, maintenance, use or removal of its structure.
5. Permittee shall schedule a pre-job field meet at least 10 days prior to any proposed start of work. No potholing will be allowed through protection slabs. Potholing locations shall be determined at the pre-job meeting before work begins.
6. Underground Service Alert (USA) must be notified two working days before any excavating or grading.
7. Permittee and its contractors and subcontractors shall not use EBMUD roads or the EBMUD aqueduct property outside the permit area to access the Permittee's work area.
8. EBMUD reserves the right to cancel its permission at any time if, in its opinion, EBMUD's property is being damaged or the security of any of its structures or premises are in danger.
9. It is understood by Permittee that pets, firearms and fires of any kind are prohibited.
10. Permittee shall have a copy of this permit in possession on site while on EBMUD land.
11. It is understood by Permittee that all plants and animal life specimens, materials or artifacts found on EBMUD land shall remain the property of EBMUD and shall not be removed without the prior written consent of EBMUD.
12. Permittee understands and agrees not to conduct any pile driving within 50 feet of EBMUD aqueduct property.
13. The type and weight of any and all equipment to be used by Permittee on EBMUD's property must be approved in advance by EBMUD. Vibratory compaction equipment is prohibited over the aqueducts.

**Temporary Construction Permit**  
**Page 3**

14. Permittee agrees to assume all risk of damage to any or all property of Permittee or any property under the control or custody of Permittee while on EBMUD property.
15. Vehicular parking and storage of equipment or materials on EBMUD's property is prohibited.
16. At least 48 hours prior to start of work, Permittee shall contact the EBMUD contact identified below.
17. The plan for the execution of the work must be approved by EBMUD prior to start of work.
18. Upon completion of work, the ground surface shall promptly be restored to as near as possible to the condition that existed prior to entry. The site will be left in a clean and presentable condition and free from waste.
19. Gravity drainage of the EBMUD property shall be maintained.
20. All work areas shall be inspected by EBMUD for final approval. An as-built drawing submittal is required before final approval can be issued.
21. All EBMUD survey monuments and markers shall be undisturbed. If any EBMUD survey marker must be disturbed, it will be replaced or relocated by EBMUD at Permittee's expense.
22. Permittee agrees to reimburse EBMUD for costs for inspection, review, permit fees/licenses and related expenses incurred by EBMUD in relation to this project.
23. Permittee shall provide evidence of liability insurance and workers' compensation coverage. Permittee shall provide such evidence on the certificates attached to this permit. EBMUD shall be named as an additional insured.
24. Permittee agrees and understands that no work may commence on EBMUD's property until this permit is executed and all certificates are properly filled out and returned to EBMUD.
25. Permittee agrees to require all of its contractors and subcontractors to comply with the terms and conditions of this permit.
26. Permittee understands and agrees that all work and use of EBMUD's property shall cease and terminate by the date shown above.



SPECIAL CONDITIONS:

1. Permittee shall call Gary Walters, Aqueduct Section Maintenance Supervisor, at 510-385-6172 for access. 24-hour notice is required.
2. Existing aqueduct protective measures such as concrete slabs shall not be cut, penetrated, or otherwise disturbed. If a protective measure is cut, penetrated, or disturbed, it shall be replaced with a new protective measure, designed by a District engineer or applicant's licensed engineer to District standards with specific District approval of design.
3. Temporary construction fences and barricades shall be installed and maintained by contractor as required by EMBUD's inspector. Should they become damaged, work will stop until they are repaired.
4. Any and all abandoned pipelines, casings, ducts, etc., encountered at this site must be removed from EBMUD right-of-way by Contractor.
5. Contractor agrees that in accordance with generally accepted construction practices, Contractor will be required to assume sole and complete responsibility for the job site conditions during the course of construction of the project, including the safety of all persons and property; that this requirement shall be made to apply continuously and not be limited to working hours.
6. The Contractor shall conform to the applicable construction safety orders of the Division of Industrial Safety of the State of California.
7. The Contractor shall comply with all State, County and City laws and ordinances, and regulations of the Department of Industrial Relations, O.S.H.A. and industrial accident commission relating to the safety and character of work, equipment and personnel.
8. No equipment in excess of 50,000 lbs. permitted on the EBMUD right-of-way.
9. Horizontal boring is not permitted.
10. Contractor agrees that in accordance with generally accepted construction practices, Contractor will be required to assume sole and complete responsibility for the job site conditions during the course of construction of the project, including the safety of all persons and property; that this requirement shall be made to apply continuously and not be limited to working hours.
11. The Contractor shall conform to the applicable construction safety orders of the Division of Industrial Safety of the State of California.

**Temporary Construction Permit**  
**Page 5**

12. The Contractor shall comply with all State, County and City laws and ordinances, and regulations of the Department of Industrial Relations, O.S.H.A. and industrial accident commission relating to the safety and character of work, equipment and personnel.

**SIGNATURES:**

**Permittee:**

**East Bay Municipal Utility District**

\_\_\_\_\_  
(Name)

\_\_\_\_\_  
(Name)

\_\_\_\_\_  
(Title)

\_\_\_\_\_  
(Title)

\_\_\_\_\_  
(Date)

\_\_\_\_\_  
(Date)

cc: Maintenance Supervisor  
File

