

CITY OF LAFAYETTE

3675 Mt. Diablo Boulevard, Suite 210
(925) 284-1951
www.ci.lafayette.ca.us



NOTICE TO CONTRACTORS BID PROPOSAL CONTRACT AGREEMENT CONTRACT SPECIAL PROVISIONS

FOR

TAYLOR BLVD / PLEASANT HILL RD SAFETY IMPROVEMENTS



City Project No. 014-9709
Federal Aid Project Number HSIPL 5404(027)

The work for which this proposal is submitted is for construction in conformance with the City of Lafayette Standard Specifications dated March 2013, special provisions (including the payment of not less than the State general prevailing wage rates or Federal minimum wage rates), the project plans described below, including any addenda thereto, the contract annexed hereto, and also in conformance with the 2010 California Department of Transportation Standard Plans, the 2010 Standard Specifications, and the Labor Surcharge and Equipment Rental Rates in effect on the date the work is accomplished.

Bid Opening Date
Thursday, December 1, 2016 11:00 a.m.

NOTICE TO CONTRACTORS

Sealed proposals will be accepted at the office of the City Clerk, 3675 Mt. Diablo Boulevard, Suite 210, Lafayette, California until 11:00 A.M., Thursday, December 1, 2016, at which time they will be publicly opened and read, for Construction of **Taylor Blvd/Pleasant Hill Rd Safety Project, Project No. 014-9709**, including, but not limited to: mobilization; traffic control and construction signage; potholing utilities; removal and disposal of traffic striping, markers and markings, asphalt concrete berm, subgrade, native materials; minor grading; construction of high-friction pavement surface treatment, concrete barrier (K-rail), metal beam guard rail, asphalt concrete berm; installation of traffic signs, stripes, markers, and markings; and all other work as shown on the Plans and as described in the Specifications to provide a complete project.

The Engineer's cost estimate is **\$95,000**.

Contract documents, including the Plans, Special Provisions, and City of Lafayette Standard Specifications, may be obtained at the City of Lafayette Engineering Services Division. The cost of Plans and Special Provisions is \$10 per set, and \$25 per copy of the Standard Specifications. The cost of mailing is an additional \$10. A link to electronic bid documents may be obtained free of charge by contacting the Engineering Secretary at (925)284-1951. Bids shall be submitted in a sealed envelope titled "**Proposal: Taylor Blvd/Pleasant Hill Rd Safety Project, Project No. 014-9709.**"

The Contractor shall possess a Class "A" or "B" license at the time this contract is awarded.

Bidder's attention is directed to requirements in Sections 2 and 3 of the Standard Specifications General Provisions.

All bids shall be accompanied by a cashier's or certified check, or a bidder's bond executed by a corporate surety insurer. The bidder's guarantee shall be in the amount equal to at least ten (10) percent of the total bid and shall be made payable to the City of Lafayette. The successful bidder shall furnish a payment bond and a performance bond.

The Owner reserves the right to waive any informalities or to reject any or all bids.

This is a federally-funded contract. The DBE Contract goal is one-half percent (0.5%). However, the City of Lafayette affirms that in any contract entered into pursuant to this advertisement, disadvantaged business enterprises will be afforded full opportunity to submit bids in response to this invitation.

The City Council has ascertained the General Prevailing Rates of Wages and Federal Minimum Wage Rates applicable to this work, and these rates are on file in the office of the City of Lafayette Engineering Services Division.

Time of completion allowed for this project will be **fifteen (15) working days**. Bidder's attention is directed to the order of work stated in Section 5 of the Special Provisions.

Questions regarding the project Plans or Specifications may be directed to Tony Coe, City Engineer, (925) 299-3203.

The plan holders list, as well as the City Standard Specifications, the Project Special Provisions and the General Prevailing Rates of Wages applicable to this work may be downloaded free of charge from the City of Lafayette web page at <http://www.ci.lafayette.ca.us> (click on City Construction Projects under the Public Works & Construction link on the homepage). Or you may contact the Engineering Secretary at (925) 284-1951.

CITY OF LAFAYETTE

Date: November 10, 2016

By: 

Tony Coe, City Engineer

TABLE OF CONTENTS

	<u>Page No.</u>
NOTICE TO CONTRACTORS	N-1
BID PROPOSAL	P-1
BID SCHEDULE	P-1
BIDDER’S LIST OF SUBCONTRACTORS (DBE AND NON-DBE) – PART I	P-4
BIDDER’S LIST OF SUBCONTRACTORS (DBE AND NON-DBE) – PART II	P-5
EQUAL EMPLOYMENT OPPORTUNITY CERTIFICATION	P-6
CONSTRUCTION CONTRACT DBE COMMITMENT	P-7
BIDDER DBE INFORMATION (GOOD FAITH EFFORTS)	P-10
PUBLIC CONTRACT CODE QUESTIONNAIRE AND STATEMENT	P-12
NON-COLLUSION AFFIDAVIT	P-14
DEBARMENT AND SUSPENSION CERTIFICATION.....	P-15
NON-LOBBYING CERTIFICATION FOR FEDERAL- AID CONTRACTS	P-16
DISCLOSURE OF LOBBYING ACTIVITIES	P-17
FEDERAL MINIMUM WAGE RATES	P-19
PROPOSAL GUARANTEE “BID BOND”	P-20
PROPOSAL SIGNATURE SHEET.....	P-21
PUBLIC WORKS CONTRACTOR REGISTRATION CERTIFICATION	P-22
CONTRACT AGREEMENT FOR CONSTRUCTION	C-1
TITLE VI ASSURANCES	C-3
REQUIRED FEDERAL AID CONSTRUCTION CONTRACT PROVISIONS (FHWA 1273).....	C-4
PAYMENT BOND	C-25
PERFORMANCE BOND	C-26
SPECIAL PROVISIONS	
GENERAL	S-1
SECTION SP-1 – TERMS, DEFINITIONS AND ABBREVIATIONS.....	S-1
SECTION SP-2 – BID PROPOSAL REQUIREMENTS.....	S-2
SECTION SP-3 – AWARD AND EXECUTION OF CONTRACT	S-8
SECTION SP-4 – PLANS AND SPECIFICATIONS (GENERAL)	S-8
SECTION SP-5 – CONTROL OF WORK AND MATERIALS	S-8
SECTION SP-6 – LEGAL RELATIONS AND RESPONSIBILITIES.....	S-10
SECTION SP-7 – EXISTING UTILITIES	S-10
SECTION SP-8 – PROGRESS OF WORK.....	S-10
SECTION SP-9 – MEASUREMENT AND PAYMENT	S-12

SECTION SP-10– (NOT USED)
SECTION SP-11– MISCELLANEOUS S-12
SECTION SP-12– MOBILIZATION S-14
SECTION SP-13– CONSTRUCTION AREA SIGNS S-15
SECTION SP-14– TRAFFIC CONTROL..... S-15
SECTION SP-15– DUST CONTROL..... S-17
SECTION SP-16– CLEARING, GRUBBING AND TREE PROTECTION S-17
SECTION SP-17– RAILINGS AND BARRIERS S-18
SECTION SP-18– BERM AND DIKE S-20
SECTION SP-19 TO 23- (NOT USED)
SECTION SP-24– HIGH-FRICTION SURFACE TREATMENT..... S-21
SECTION SP-25– TEMPORARY PAVEMENT DELINEATION S-25
SECTION SP-26– SIGNING AND STRIPING S-25

- APPENDIX A: WASTE MANAGEMENT PLAN & WASTE ASSESSMENT FORM**
- APPENDIX B: STANDARD PLANS**
- APPENDIX C: CITY OF LAFAYETTE QUALITY ASSURANCE PROGRAM (QAP)**
- APPENDIX D: PROJECT PLAN**

**CITY OF LAFAYETTE, CALIFORNIA
BID PROPOSAL**

**TAYLOR BLVD/PLEASANT HILL RD SAFETY PROJECT
PROJECT NO. 014-9708**

TO THE CITY COUNCIL OF THE CITY OF LAFAYETTE:

In compliance with the annexed notice inviting sealed proposals, the undersigned bidder hereby proposes and agrees to perform the work therein described and to furnish all labor, materials and equipment necessary therefor, in accordance with the Plans and Specifications therefor, and further agrees to enter into a contract therefor, at the following prices:

ITEM NO.	ITEM DESCRIPTION	ESTIMATED QUANTITY	UNIT	UNIT PRICE	TOTAL
1	Mobilization	1	LS	\$	\$
2	Construction Area Signs	1	LS		
3	Traffic Control	1	LS		
4	Clearing and Grubbing	1	LS		
5	Metal Beam Guard Rail (S)	100	LF		
6	Concrete Barrier Rail (S)	280	LF		
7	High Friction Surface Treatment (S)	1,000	SY		
8	Signing and Striping	1	LS		
	Bid Total				\$

- NOTES: - All unit prices shall be considered the prices for providing a complete, in-place facility.
 In the event of a discrepancy between the unit price and item total on the bid Schedule, the unit price shall be used.
 (S) denotes "Specialty Item" for the purpose of Standard Specifications General Provisions Section 2-13.

Bidder acknowledges the receipt of the following addenda to the drawings and specifications.

<u>Addendum No.</u>	<u>Date</u>	<u>Addendum No.</u>	<u>Date</u>
_____	_____	_____	_____
_____	_____	_____	_____

o o o

Bidder agrees that in case of default in executing and returning the required contract and bonds within ten (10) calendar days after having received the contract, proceeds of the guarantee accompanying his bid will become the property of the City of Lafayette.

o o o

Bidder certifies that he is licensed in accordance with an act providing for the registration of Contractors as follows:

License No. _____ Class _____

o o o

Bidder certifies that he has not, nor have any of his or its agents, officers, representatives, or employees, been guilty of collusion with any officer or representative of the City of Lafayette or with any other party or parties in the submission of this proposal; nor has said bidder received any preferential treatment by any officer or employee of the City of Lafayette in the matter of making or submitting this proposal. The undersigned declares under penalty of perjury that the foregoing is true and correct.

o o o

Bidder certifies, under penalty of perjury under the laws of the State of California, that the questionnaire and statements of Public Contract Code Sections 10162, 10232 and 10285.1 in the subsequent pages of this Proposal are true and correct and that the bidder has complied with the requirements of Section 8103 of the Fair Employment and Housing Commission Regulations (Chapter 5, Title 2 of the California Administrative Code). Bidder further certifies, under penalty of perjury under the laws of the State of California and the United States of America, that the Noncollusion Affidavit required by Title 23 United States Code, Section 112 and Public Contract Code Section 7106; and the Title 49 Code of Federal Regulations, Part 29 Debarment and Suspension Certification are true and correct.

Bidder certifies that there will be no discrimination in employment with regard to race, color, religion, sex, sexual orientation, or national origin; that all Federal, State, and local directives and executive orders regarding nondiscrimination in employment will be complied with and that the principle of equal opportunity in employment will be demonstrated positively and aggressively.

All bidders that have not had a contract with the City of Lafayette during the past three (3) years shall list below previous jobs that they have successfully completed and shall also show the amount of the contract therefor.

Name and Address of Agency or Individual for Whom Work was Done	Phone Number	Date Completed	Contract Price
1.			
2.			
3.			
4.			
5.			
6.			

o o o

In conformance with Subsection 2-13 "Listing of Proposed Subcontractors" of the Standard Specifications and Title 49, Section 26 of the Code of Federal Regulations, Contractor shall completely fill out the "Bidder's List of Subcontractors (DBE and Non-DBE)—Part I and Part II" forms as follows:

EXHIBIT 12B - BIDDER'S LIST OF SUBCONTRACTORS (DBE and NON-DBE)- PART I

The bidder shall list all subcontractors (both DBE and non-DBE) in accordance with Section 2-1.054 of the State Specifications and per Title 49, Section 26.11 of the Code of Federal Regulations. This listing is required in addition to listing DBE Subcontractors elsewhere in the proposal. **Photocopy this form for additional firms.**

Firm Name/ Address/ City, State, ZIP		Phone/ Fax	Annual Gross Receipts	Description of Portion of Work to be Performed	Local Agency Use Only (Certified DBE?)
Name		Phone	<input type="checkbox"/> < \$1 million		<input type="checkbox"/> YES
Address			<input type="checkbox"/> < \$5 million		<input type="checkbox"/> NO
City State Zip		Fax	<input type="checkbox"/> < \$10 million		If YES list DBE #:
			<input type="checkbox"/> < \$15 million		Age of Firm (Yrs.)
			<input type="checkbox"/> > \$15 million		
Name		Phone	<input type="checkbox"/> < \$1 million		<input type="checkbox"/> YES
Address			<input type="checkbox"/> < \$5 million		<input type="checkbox"/> NO
City State Zip		Fax	<input type="checkbox"/> < \$10 million		If YES list DBE #:
			<input type="checkbox"/> < \$15 million		Age of Firm (Yrs.)
			<input type="checkbox"/> > \$15 million		
Name		Phone	<input type="checkbox"/> < \$1 million		<input type="checkbox"/> YES
Address			<input type="checkbox"/> < \$5 million		<input type="checkbox"/> NO
City State Zip		Fax	<input type="checkbox"/> < \$10 million		If YES list DBE #:
			<input type="checkbox"/> < \$15 million		Age of Firm (Yrs.)
			<input type="checkbox"/> > \$15 million		
Name		Phone	<input type="checkbox"/> < \$1 million		<input type="checkbox"/> YES
Address			<input type="checkbox"/> < \$5 million		<input type="checkbox"/> NO
City State Zip		Fax	<input type="checkbox"/> < \$10 million		If YES list DBE #:
			<input type="checkbox"/> < \$15 million		Age of Firm (Yrs.)
			<input type="checkbox"/> > \$15 million		

EXHIBIT 12B - BIDDER'S LIST OF SUBCONTRACTORS (DBE and NON-DBE)- PART II

The bidder shall list all subcontractors who provided a quote or bid but were not selected to participate as a subcontractor on this project. This is required for compliance with Title 49, Section 26 of the Code of Federal Regulations. **Photocopy this form for additional firms.**

Firm Name/ Address/ City, State, ZIP		Phone/ Fax	Annual Gross Receipts	Description of Portion of Work to be Performed	Local Agency Use Only (Certified DBE?)
Name		Phone	<input type="checkbox"/> < \$1 million		<input type="checkbox"/> YES
Address			<input type="checkbox"/> < \$5 million		<input type="checkbox"/> NO
City State Zip		Fax	<input type="checkbox"/> < \$10 million		If YES list DBE #:
			<input type="checkbox"/> < \$15 million		Age of Firm (Yrs.)
			<input type="checkbox"/> > \$15 million		
Name		Phone	<input type="checkbox"/> < \$1 million		<input type="checkbox"/> YES
Address			<input type="checkbox"/> < \$5 million		<input type="checkbox"/> NO
City State Zip		Fax	<input type="checkbox"/> < \$10 million		If YES list DBE #:
			<input type="checkbox"/> < \$15 million		Age of Firm (Yrs.)
			<input type="checkbox"/> > \$15 million		
Name		Phone	<input type="checkbox"/> < \$1 million		<input type="checkbox"/> YES
Address			<input type="checkbox"/> < \$5 million		<input type="checkbox"/> NO
City State Zip		Fax	<input type="checkbox"/> < \$10 million		If YES list DBE #:
			<input type="checkbox"/> < \$15 million		Age of Firm (Yrs.)
			<input type="checkbox"/> > \$15 million		
Name		Phone	<input type="checkbox"/> < \$1 million		<input type="checkbox"/> YES
Address			<input type="checkbox"/> < \$5 million		<input type="checkbox"/> NO
City State Zip		Fax	<input type="checkbox"/> < \$10 million		If YES list DBE #:
			<input type="checkbox"/> < \$15 million		Age of Firm (Yrs.)
			<input type="checkbox"/> > \$15 million		

EQUAL EMPLOYMENT OPPORTUNITY CERTIFICATION

The bidder _____, proposed subcontractor _____, hereby certifies that he has _____, has not _____, participated in a previous contract or subcontract subject to the equal opportunity clauses, as required by Executive Orders 10925, 11114, or 11246, and that, where required, he has filed with the Joint Reporting Committee, the Director of the Office of Federal Contract Compliance, a Federal Government contracting or administering agency, or the former President's Committee on Equal Employment Opportunity, all reports due under the applicable filing requirements.

Note: The above certification is required by the Equal Employment Opportunity Regulations of the Secretary of Labor (41 CFR 60-1.7(b) (1)), and must be submitted by bidders and proposed subcontractors only in connection with contracts and subcontracts which are subject to the equal opportunity clause. Contracts and subcontracts which are exempt from the equal opportunity clause are set forth in 41 CFR 60-1.5. (Generally only contracts or subcontracts of \$10,000 or under are exempt.)

Currently, Standard Form 100 (EEO-1) is the only report required by the Executive Orders or their implementing regulations.

Proposed prime contractors and subcontractors who have participated in a previous contract or subcontract subject to the Executive Orders and have not filed the required reports should note that 41 CFR 60-1.7(b) (1) prevents the award of contracts and subcontracts unless such contractor submits a report covering the delinquent period or such other period specified by the Federal Highway Administration or by the Director, Office of Federal Contract Compliance, U.S. Department of Labor.

EXHIBIT 15-G CONSTRUCTION CONTRACT DBE COMMITMENT

1. Local Agency: _____ 2. Contract DBE Goal: _____
 3. Project Description: _____
 4. Project Location: _____
 5. Bidder's Name: _____ 6. Prime Certified DBE: 7. Bid Amount: _____
 8. Total Dollar Amount for **ALL** Subcontractors: _____ 9. Total Number of **ALL** Subcontractors: _____

10. Bid Item Number	11. Description of Work, Service, or Materials Supplied	12. DBE Certification Number	13. DBE Contact Information (Must be certified on the date bids are opened)	14. DBE Dollar Amount
Local Agency to Complete this Section 21. Local Agency Contract Number: _____ 22. Federal-Aid Project Number: _____ 23. Bid Opening Date: _____ 24. Contract Award Date: _____ Local Agency certifies that all DBE certifications are valid and information on this form is complete and accurate.			15. TOTAL CLAIMED DBE PARTICIPATION IMPORTANT: Identify all DBE firms being claimed for credit, regardless of tier. Names of the First Tier DBE Subcontractors and their respective item(s) of work listed above must be consistent, where applicable with the names and items of the work in the "Subcontractor List" submitted with your bid. Written confirmation of each listed DBE is required.	\$ _____
25. Local Agency Representative's Signature _____ 26. Date _____ 27. Local Agency Representative's Name _____ 28. Phone _____ 29. Local Agency Representative's Title _____				% _____ 16. Preparer's Signature _____ 17. Date _____ 18. Preparer's Name _____ 19. Phone _____ 20. Preparer's Title _____

DISTRIBUTION: 1. Original – Local Agency
 2. Copy – Caltrans District Local Assistance Engineer (DLAE). Failure to submit to DLAE within 30 days of contract execution may result in de-obligation of federal funds on contract. Include additional copy with award package.

INSTRUCTIONS – CONSTRUCTION CONTRACT DBE COMMITMENT

CONTRACTOR SECTION

1. **Local Agency** - Enter the name of the local or regional agency that is funding the contract.
2. **Contract DBE Goal** - Enter the contract DBE goal percentage as it appears on the project advertisement.
3. **Project Location** - Enter the project location as it appears on the project advertisement.
4. **Project Description** - Enter the project description as it appears on the project advertisement (Bridge Rehab, Seismic Rehab, Overlay, Widening, etc).
5. **Bidder's Name** - Enter the contractor's firm name.
6. **Prime Certified DBE** - Check box if prime contractor is a certified DBE.
7. **Bid Amount** - Enter the total contract bid dollar amount for the prime contractor.
8. **Total Dollar Amount for ALL Subcontractors** – Enter the total dollar amount for all subcontracted contractors. SUM = (DBEs + all Non-DBEs). Do not include the prime contractor information in this count.
9. **Total number of ALL subcontractors** – Enter the total number of all subcontracted contractors. SUM = (DBEs + all Non-DBEs). Do not include the prime contractor information in this count.
10. **Bid Item Number** - Enter bid item number for work, services, or materials supplied to be provided.
11. **Description of Work, Services, or Materials Supplied** - Enter description of work, services, or materials to be provided. Indicate all work to be performed by DBEs including work performed by the prime contractor's own forces, if the prime is a DBE. If 100% of the item is not to be performed or furnished by the DBE, describe the exact portion to be performed or furnished by the DBE. See LAPM Chapter 9 to determine how to count the participation of DBE firms.
12. **DBE Certification Number** - Enter the DBE's Certification Identification Number. All DBEs must be certified on the date bids are opened.
13. **DBE Contact Information** - Enter the name, address, and phone number of all DBE subcontracted contractors. Also, enter the prime contractor's name and phone number, if the prime is a DBE.
14. **DBE Dollar Amount** - Enter the subcontracted dollar amount of the work to be performed or service to be provided. Include the prime contractor if the prime is a DBE. See LAPM Chapter 9 for how to count full/partial participation.
15. **Total Claimed DBE Participation** - \$: Enter the total dollar amounts entered in the "DBE Dollar Amount" column. %: Enter the total DBE participation claimed ("Total Claimed DBE Participation Dollars" divided by item "Bid Amount"). If the total % claimed is less than item "Contract DBE Goal," an adequately documented Good Faith Effort (GFE) is required (see Exhibit 15-H DBE Information - Good Faith Efforts of the LAPM).
16. **Preparer's Signature** - The person completing the DBE commitment form on behalf of the contractor's firm must sign their name.
17. **Date** - Enter the date the DBE commitment form is signed by the contractor's preparer.
18. **Preparer's Name** - Enter the name of the person preparing and signing the contractor's DBE commitment form.
19. **Phone** - Enter the area code and phone number of the person signing the contractor's DBE commitment form.
20. **Preparer's Title** - Enter the position/title of the person signing the contractor's DBE commitment form.

LOCAL AGENCY SECTION

21. **Local Agency Contract Number** - Enter the Local Agency contract number or identifier.
22. **Federal-Aid Project Number** - Enter the Federal-Aid Project Number.
23. **Bid Opening Date** - Enter the date contract bids were opened.
24. **Contract Award Date** - Enter the date the contract was executed.
25. **Local Agency Representative's Signature** - The person completing this section of the form for the Local Agency must sign their name to certify that the information in this and the Contractor Section of this

form is complete and accurate.

26. Date - Enter the date the DBE commitment form is signed by the Local Agency Representative.

27. Local Agency Representative's Name - Enter the name of the Local Agency Representative certifying the contractor's DBE commitment form.

28. Phone - Enter the area code and phone number of the person signing the contractor's DBE commitment form.

29. Local Agency Representative Title - Enter the position/title of the Local Agency Representative certifying the contractor's DBE commitment form.

EXHIBIT 15-H
DBE INFORMATION - GOOD FAITH EFFORTS

Federal-aid Project No. _____ Bid Opening Date: _____

The City of Lafayette established a Disadvantaged Business Enterprise (DBE) goal of 0.5% for this project. The information provided herein shows that a good faith effort was made.

Lowest, second lowest and third lowest bidders shall submit the following information to document adequate good faith efforts. Bidders should submit the following information even if the "Local Agency Bidder DBE Commitment" form indicates that the bidder has met the DBE goal. This will protect the bidder's eligibility for award of the contract if the administering agency determines that the bidder failed to meet the goal for various reasons, e.g., a DBE firm was not certified at bid opening, or the bidder made a mathematical error.

Submittal of only the "Local Agency Bidder DBE Commitment" form may not provide sufficient documentation to demonstrate that adequate good faith efforts were made.

The following items are listed in the Section entitled "Submission of DBE Commitment" of the Special Provisions:

- A. The names and dates of each publication in which a request for DBE participation for this project was placed by the bidder (please attach copies of advertisements or proofs of publication):

Publications	Dates of Advertisement

- B. The names and dates of written notices sent to certified DBEs soliciting bids for this project and the dates and methods used for following up initial solicitations to determine with certainty whether the DBEs were interested (please attach copies of solicitations, telephone records, fax confirmations, etc.):

Names of DEBs Solicited	Date of Initial Solicitation	Follow up Methods and Dates

- C. The items of work which the bidder made available to DBE firms including, where appropriate, any breaking down of the contract work items (including those items normally performed by the bidder with its own forces) into economically feasible units to facilitate DBE participation. It is the bidder's responsibility to demonstrate that sufficient work to facilitate DBE participation was made available to DBE firms.

Items of Work	Bidder Normally Performs Item (Y/N)	Breakdown of Items	Amount (\$)	Percentage of Contract

- D. The names, addresses and phone numbers of rejected DBE firms, the reasons for the bidder's rejection of the DBEs, the firms selected for that work (please attach copies of quotes from the firms involved), and the price difference for each DBE if the selected firm is not a DBE:

Names, addresses and phone numbers of rejected DBEs and the reasons for the bidder's rejection of the DBEs:

Names, addresses and phone numbers of firms selected for the work above:

- E. Efforts made to assist interested DBEs in obtaining bonding, lines of credit or insurance, and any technical assistance or information related to the plans, specifications and requirements for the work which was provided to DBEs:

PUBLIC CONTRACT CODE

Public Contract Code Section 10285.1 Statement

In conformance with Public Contract Code Section 10285.1 (Chapter 376, Stats. 1985), the bidder hereby declares under penalty of perjury under the laws of the State of California that the bidder has ____, has not ____ been convicted within the preceding three years of any offenses referred to in that section, including any charge of fraud, bribery, collusion, conspiracy, or any other act in violation of any state or Federal antitrust law in connection with the bidding upon, award of, or performance of, any public works contract, as defined in Public Contract Code Section 1101, with any public entity, as defined in Public Contract Code Section 1100, including the Regents of the University of California or the Trustees of the California State University. The term "bidder" is understood to include any partner, member, officer, director, responsible managing officer, or responsible managing employee thereof, as referred to in Section 10285.1.

Note: The bidder must place a checkmark after "has" or "has not" in one of the blank spaces provided. The above Statement is part of the Proposal. Signing this Proposal on the signature portion thereof shall also constitute signature of this Statement. Bidders are cautioned that making a false certification may subject the certifier to criminal prosecution.

Public Contract Code Section 10162 Questionnaire

In conformance with Public Contract Code Section 10162, the Bidder shall complete, under penalty of perjury, the following questionnaire:

Has the bidder, any officer of the bidder, or any employee of the bidder who has a proprietary interest in the bidder, ever been disqualified, removed, or otherwise prevented from bidding on, or completing a federal, state, or local government project because of a violation of law or a safety regulation?

Yes _____ No _____

If the answer is yes, explain the circumstances in the following space.

Public Contract Code 10232 Statement

In conformance with Public Contract Code Section 10232, the Contractor, hereby states under penalty of perjury, that no more than one final unappealable finding of contempt of court by a federal court has been issued against the Contractor within the immediately preceding two-year period because of the Contractor's failure to comply with an order of a federal court which orders the Contractor to comply with an order of the National Labor Relations Board.

Note: The above Statement and Questionnaire are part of the Proposal. Signing this Proposal on the signature portion thereof shall also constitute signature of this Statement and Questionnaire.

Bidders are cautioned that making a false certification may subject the certifier to criminal prosecution.

Noncollusion Affidavit
(Title 23 United States Code Section 112 and
Public Contract Code Section 7106)

To the CITY OF LAFAYETTE
ENGINEERING DIVISION

In conformance with Title 23 United States Code Section 112 and Public Contract Code 7106 the bidder declares that the bid is not made in the interest of, or on behalf of, any undisclosed person, partnership, company, association, organization, or corporation; that the bid is genuine and not collusive or sham; that the bidder has not directly or indirectly induced or solicited any other bidder to put in a false or sham bid, and has not directly or indirectly colluded, conspired, connived, or agreed with any bidder or anyone else to put in a sham bid, or that anyone shall refrain from bidding; that the bidder has not in any manner, directly or indirectly, sought by agreement, communication, or conference with anyone to fix the bid price of the bidder or any other bidder, or to fix any overhead, profit, or cost element of the bid price, or of that of any other bidder, or to secure any advantage against the public body awarding the contract of anyone interested in the proposed contract; that all statements contained in the bid are true; and, further, that the bidder has not, directly or indirectly, submitted his or her bid price or any breakdown thereof, or the contents thereof, or divulged information or data relative thereto, or paid, and will not pay, any fee to any corporation, partnership, company association, organization, bid depository, or to any member or agent thereof to effectuate a collusive or sham bid.

Note: The above Noncollusion Affidavit is part of the Proposal. Signing this Proposal on the signature portion thereof shall also constitute signature of this Noncollusion Affidavit.

Bidders are cautioned that making a false certification may subject the certifier to criminal prosecution.

**DEBARMENT AND SUSPENSION CERTIFICATION
TITLE 49, CODE OF FEDERAL REGULATIONS, PART 29**

The bidder, under penalty of perjury, certifies that, except as noted below, he/she or any other person associated therewith in the capacity of owner, partner, director, officer, manager:

- is not currently under suspension, debarment, voluntary exclusion, or determination of ineligibility by any Federal agency;
- has not been suspended, debarred, voluntarily excluded or determined ineligible by any Federal agency within the past 3 years;
- does not have a proposed debarment pending; and
- has not been indicted, convicted, or had a civil judgment rendered against it by a court of competent jurisdiction in any matter involving fraud or official misconduct within the past 3 years.

If there are any exceptions to this certification, insert the exceptions in the following space.

Exceptions will not necessarily result in denial of award, but will be considered in determining bidder responsibility. For any exception noted above, indicate below to whom it applies, initiating agency, and dates of action.

Notes: Providing false information may result in criminal prosecution or administrative sanctions. The above certification is part of the Proposal. Signing this Proposal on the signature portion thereof shall also constitute signature of this Certification.

**NONLOBBYING CERTIFICATION
FOR FEDERAL-AID CONTRACTS**

The prospective participant certifies, by signing and submitting this bid or proposal, to the best of his or her knowledge and belief, that:

- (1) No Federal appropriated funds have been paid or will be paid, by or on behalf of the undersigned, to any person for influencing or attempting to influence an officer or employee of any Federal agency, a Member of Congress, an officer or employee of Congress, or an employee of a Member of Congress in connection with the awarding of any Federal contract, the making of any Federal grant, the making of any Federal loan, the entering into of any cooperative agreement, and the extension, continuation, renewal, amendment, or modification of any Federal contract, grant, loan, or cooperative agreement.
- (2) If any funds other than Federal appropriated funds have been paid or will be paid to any person for influencing or attempting to influence an officer or employee of any Federal agency, a Member of Congress, an officer or employee of Congress, or an employee of a Member of Congress in connection with this Federal contract, grant, loan, or cooperative agreement, the undersigned shall complete and submit Standard Form-LLL, "Disclosure of Lobbying Activities," in conformance with its instructions.

This certification is a material representation of fact upon which reliance was placed when this transaction was made or entered into. Submission of this certification is a prerequisite for making or entering into this transaction imposed by Section 1352, Title 31, U.S. Code. Any person who fails to file the required certification shall be subject to a civil penalty of not less than \$10,000 and not more than \$100,000 for each such failure.

The prospective participant also agrees by submitting his or her bid or proposal that he or she shall require that the language of this certification be included in all lower tier subcontracts, which exceed \$100,000 and that all such subrecipients shall certify and disclose accordingly.

DISCLOSURE OF LOBBYING ACTIVITIES

COMPLETE THIS FORM TO DISCLOSE LOBBYING ACTIVITIES PURSUANT TO 31 U.S.C. 1352

1. Type of Federal Action:

- a. contract
- b. grant
- c. cooperative agreement
- d. loan
- e. loan guarantee
- f. loan insurance

2. Status of Federal Action:

- a. bid/offer/application
- b. initial award
- c. post-award

3. Report Type:

- a. initial
- b. material change

For Material Change Only:

year _____ quarter _____
date of last report _____

4. Name and Address of Reporting Entity

- Prime
- Subawardee
Tier _____, if known

Congressional District, if known

5. If Reporting Entity in No. 4 is Subawardee, Enter Name and Address of Prime:

Congressional District, if known

6. Federal Department/Agency:

7. Federal Program Name/Description:

CFDA Number, if applicable _____

8. Federal Action Number, if known:

9. Award Amount, if known:

10. a. Name and Address of Lobby Entity
(If individual, last name, first name, MI)

b. Individuals Performing Services (including address if different from No. 10a)
(last name, first name, MI)

(attach Continuation Sheet(s) if necessary)

11. Amount of Payment (check all that apply)

\$ _____ actual planned

13. Type of Payment (check all that apply)

- a. retainer
- b. one-time fee
- c. commission
- d. contingent fee
- e. deferred
- f. other, specify _____

12. Form of Payment (check all that apply):

- a. cash
- b. in-kind; specify: nature _____
value _____

14. Brief Description of Services Performed or to be performed and Date(s) of Service, including officer(s), employee(s), or member(s) contacted, for Payment Indicated in Item 11:

(attach Continuation Sheet(s) if necessary)

15. Continuation Sheet(s) attached: Yes No

16. Information requested through this form is authorized by Title 31 U.S.C. Section 1352. This disclosure of lobbying reliance was placed by the tier above when his transaction was made or entered into. This disclosure is required pursuant to 31 U.S.C. 1352. This information will be reported to Congress semiannually and will be available for public inspection. Any person who fails to file the required disclosure shall be subject to a civil penalty of not less than \$10,000 and not more than \$100,000 for each such failure.

Signature: _____

Print Name: _____

Title: _____

Telephone No.: _____ Date: _____

Federal Use Only:

Authorized for Local Reproduction
Standard Form – LLL rev 09-12-97

INSTRUCTIONS FOR COMPLETION OF SF-LLL DISCLOSURE OF LOBBYING ACTIVITIES

This disclosure form shall be completed by the reporting entity, whether subawardee or prime Federal recipient, at the initiation or receipt of covered Federal action or a material change to previous filing pursuant to title 31 U.S.C. section 1352. The filing of a form is required for such payment or agreement to make payment to lobbying entity for influencing or attempting to influence an officer or employee of any agency, a Member of Congress an officer or employee of Congress or an employee of a Member of Congress in connection with a covered Federal action. Attach a continuation sheet for additional information if the space on the form is inadequate. Complete all items that apply for both the initial filing and material change report. Refer to the implementing guidance published by the Office of Management and Budget for additional information.

1. Identify the type of covered Federal action for which lobbying activity is and/or has been secured to influence, the outcome of a covered Federal action.
2. Identify the status of the covered Federal action.
3. Identify the appropriate classification of this report. If this is a follow-up report caused by a material change to the information previously reported, enter the year and quarter in which the change occurred. Enter the date of the last, previously submitted report by this reporting entity for this covered Federal action.
4. Enter the full name, address, city, state and zip code of the reporting entity. Include Congressional District if known. Check the appropriate classification of the reporting entity that designates if it is or expects to be a prime or subaward recipient. Identify the tier of the subawardee, e.g., the first subawardee of the prime is the first tier. Subawards include but are not limited to subcontracts, subgrants and contract awards under grants.
5. If the organization filing the report in Item 4 checks "Subawardee" then enter the full name, address, city, state and zip code of the prime Federal recipient. Include Congressional District, if known.
6. Enter the name of the Federal agency making the award or loan commitment. Include at least one organization level below agency name, if known. For example, Department of Transportation, United States Coast Guard.
7. Enter the Federal program name or description for the covered Federal action (item 1). If known, enter the full Catalog of Federal Domestic Assistance (CFDA) number for grants, cooperative agreements, loans and loan commitments.
8. Enter the most appropriate Federal identifying number available for the Federal action identification in item 1 (e.g., Request for Proposal (RFP) number, Invitation for Bid (IFB) number, grant announcement number, the contract grant. or loan award number, the application/proposal control number assigned by the Federal agency). Include prefixes, e.g., "RFP-DE-90-001."
9. For a covered Federal action where there has been an award or loan commitment by the Federal agency, enter the Federal amount of the award/loan commitments for the prime entity identified in item 4 or 5.
10. (a) Enter the full name, address, city, state and zip code of the lobbying entity engaged by the reporting entity identified in item 4 to influenced the covered Federal action.
(b) Enter the full names of the individual(s) performing services and include full address if different from 10 (a). Enter Last Name, First Name and Middle Initial (MI).
11. Enter the amount of compensation paid or reasonably expected to be paid by the reporting entity (item 4) to the lobbying entity (item 10). Indicate whether the payment has been made (actual) or will be made (planned). Check all boxes that apply. If this is a material change report, enter the cumulative amount of payment made or planned to be made.
12. Check the appropriate box(es). Check all boxes that apply. If payment is made through an in-kind contribution, specify the nature and value of the in-kind payment.
13. Check the appropriate box(es). Check all boxes that apply. If other, specify nature.
14. Provide a specific and detailed description of the services that the lobbyist has performed or will be expected to perform and the date(s) of any services rendered. Include all preparatory and related activity not just time spent in actual contact with Federal officials. Identify the Federal officer(s) or employee(s) contacted or the officer(s) employee(s) or Member(s) of Congress that were contacted.
15. Check whether or not a continuation sheet(s) is attached.
16. The certifying official shall sign and date the form, print his/her name title and telephone number.

Public reporting burden for this collection of information is estimated to average 30 minutes per response, including time for reviewing instruction, searching existing data sources, gathering and maintaining the data needed, and completing and reviewing the collection of information. Send comments regarding the burden estimate or any other aspect of this collection of information, including suggestions for reducing this burden, to the Office of Management and Budget, Paperwork Reduction Project (0348-0046), Washington, D.C. 20503.

SF-LLL-Instructions Rev. 06-04-90«ENDIF

FEDERAL MINIMUM WAGE RATES

For the current rates, go to <http://www.wdol.gov/wdol/scafiles/davisbacon/CA29.dvb> .

**PROPOSAL GUARANTEE
BID BOND**

**TAYLOR BLVD/PLEASANT HILL RD SAFETY PROJECT
PROJECT NO. 014-9709**

KNOW ALL PERSONS BY THESE PRESENTS that _____, as BIDDER, and _____, as SURETY, are held and firmly bound unto City of Lafayette, as Owner, in the penal sum of _____ dollars (\$) which is ten percent of the total amount bid by BIDDER to Owner for the above stated project, for the payment of which sum, BIDDER and SURETY agree to be bound, jointly and severally, firmly by these presents.

THE CONDITIONS OF THIS OBLIGATION ARE SUCH that, whereas BIDDER is about to submit a bid to Owner for the above stated project, if said bid is rejected, or if said bid is accepted and a contract is awarded and entered into by BIDDER in the manner and time specified, then this obligation shall be null and void, otherwise it shall remain in full force and effect in favor of Owner.

IN WITNESS WHEREOF the parties hereto have set their names, titles, hands, and seals this ____ day of _____, 2016.

BIDDER _____

SURETY _____

Subscribed and sworn to this ____ day of _____, 2016.

NOTARY PUBLIC _____

PROPOSAL SIGNATURE SHEET

The completed proposal submitted herewith includes all sheets numbered "P-1 through P-22" at the bottom. The following required attachments have been executed and are included:

- a. Bid Proposal (with Addenda acknowledgement)
- b. Bid Schedule
- c. Bidder's List of Subcontractors (DBE and Non-DBE)-Part I
- d. Bidder's List of Subcontractors (DBE and Non-DBE)-Part II
- e. Equal Employment Opportunity Certification
- f. Construction Contract DBE Commitment Exhibit 15-G
- g. DBE Information-Good Faith Efforts Exhibit 15-H
- h. Public Contract Code Statement
- i. Public Contract Code Questionnaire and Statement
- j. Affidavit of Non-Collusion with Notarized Signature
- k. Debarment and Suspension Certification
- l. Non-Lobbying Certification for Federal Aid contracts
- m. Disclosure of Lobbying Activities
- n. Federal Minimum Wage Rates
- o. Proposal Guarantee "Bid Bond" with Notarized Signatures
- p. Proposal Signature Sheet
- q. Public Works Contractor Registration Certification

Legal Name of Firm: _____

Business Address: _____

Telephone Number: () _____

Type of Organization: () Individual () Partnership () Corporation

Joint Venture Proposal? () Yes () No

Authorized Signature: _____ Date: _____

Name: _____ Position: _____

For a partnership, name all co-partners below,
For a corporation, name president, secretary, treasurer and manager.

NAME	TITLE
_____	_____
_____	_____
_____	_____

Corporate Seal:

PUBLIC WORKS CONTRACTOR REGISTRATION CERTIFICATION

Pursuant to Labor Code sections 1725.5 and 1771.1, all contractors and subcontractors that wish to bid on, be listed in a bid proposal, or enter into a contract to perform public work must be registered with the Department of Industrial Relations. See <http://www.dir.ca.gov/Public-Works/PublicWorks.html> for additional information.

No bid will be accepted nor any contract entered into without proof of the contractor's and subcontractors' current registration with the Department of Industrial Relations to perform public work.

Contractor hereby certifies that it is aware of the registration requirements set forth in Labor Code sections 1725.5 and 1771.1 and is currently registered as a contractor with the Department of Industrial Relations.

Name of Contractor: _____

DIR Registration Number: _____

Contractor further acknowledges:

1. Contractor shall maintain a current DIR registration for the duration of the project.
2. Contractor shall include the requirements of Labor Code sections 1725.5 and 1771.1 in its contract with subcontractors and ensure that all subcontractors are registered at the time of bid opening and maintain registration status for the duration of the project.
3. Failure to submit this form or comply with any of the above requirements may result in a finding that the bid is non-responsive.

Signature: _____

Name and Title: _____

Dated: _____

CITY OF LAFAYETTE
CONTRACT AGREEMENT
FOR
CONSTRUCTION

THIS AGREEMENT is made and entered into as of _____, 2016, by and between the CITY OF LAFAYETTE ("City") and _____ ("Contractor").

RECITALS

- A. City desires to retain the services of Contractor to provide services for Construction of **Taylor Blvd/Pleasant Hill Rd Safety Project, Project No. 014-9708**, including, but not limited to: mobilization; traffic control and construction signage; potholing utilities; removal and disposal of traffic striping, markers and markings, asphalt concrete berm, subgrade, native materials; minor grading; construction of high-friction pavement surface treatment, concrete barrier (K-rail), metal beam guard rail, asphalt concrete berm; installation of traffic signs, stripes, markers, and markings; and all other work as shown on the Plans and as described in the Specifications to provide a complete project.
- B. Contractor has represented to City that it has the expertise, experience and qualifications to perform the services described in Paragraph A, above, and those services which are more fully described below.

NOW, THEREFORE, in consideration of the foregoing and the covenants and agreements set forth below, City and Contractor agree as follow:

1. Contract Documents. The contract documents for the aforesaid project shall consist of the Notice to Contractors, Bid Proposal, General Provisions, Technical Provisions, Special Provisions including appendices, Design Drawings, and all referenced specifications, details, standard drawings, and their appendices; together with this Contract Agreement and all required bonds, insurance certificates, permits, notices and affidavits; and also including any and all addenda or supplemental agreements clarifying, amending, or extending the work contemplated as may be required to insure its completion in an acceptable manner. All of the provisions of said contract documents are made a part hereof as though fully set forth herein.
1. Services. For and in consideration of the payments and agreements to be made and performed by City, Contractor agrees to furnish all materials and perform all work required for the above-stated project, and to fulfill all other obligations as set forth in the aforesaid contract documents. Contractor agrees to receive and accept the prices set forth in the Proposal as full compensation for furnishing all materials, performing all work, and fulfilling all obligations hereunder. Said compensation shall cover all expenses, losses, damages, and consequences arising out of the nature of the work during its progress or prior to its acceptance including those for well and faithfully completing the work and the whole thereof in the manner and time specified in the aforesaid contract documents; also including those arising from actions of the elements, unforeseen difficulties or obstructions encountered in the prosecution of the work, suspension or discontinuance of the work, and all other unknowns or risks of any description connected with the work.
3. Employment by City. City hereby promises and agrees to employ, and does hereby employ, Contractor to provide the materials, do the work, and fulfill the obligations according to the terms and conditions herein contained and referred to, for the prices aforesaid, and hereby contracts to pay the same at the time, in the manner, and upon the conditions set forth in the contract documents.

4. Worker's Compensation. Contractor acknowledges the provisions of the State Labor Code requiring every employer to be insured against liability for worker's compensation, or to undertake self-insurance in accordance with the provisions of that Code, and certifies compliance with such provisions. Limits shall be not less than those specified in the insurance requirements contained in the General Provisions of the Standard Specifications, and as modified in these Special Provisions.
5. Insurance. With respect to performance of work under this contract, Contractor shall maintain and shall require all of its subcontractors to maintain insurance as required in the General Provisions of the Standard Specifications, and as modified in these Special Provisions.
6. Indemnity. Contractor shall comply with the indemnification requirements contained in the General Provisions of the Standard Specifications.
7. Assignment. This contract is not assignable nor the performance of either party's duties delegable without the prior written consent of the other party. Any attempted or purported assignment or delegation of any of the rights or obligations of either party without the prior written consent of the other shall be void and of no force and effect.
8. Non-discrimination. Contractor shall not discriminate in the hiring of employees or in the employment of subcontractors on any basis prohibited by law.
9. Independent Contractor. Contractor is and shall at all times remain as to City, a wholly independent contractor. Neither City nor any of its agents shall have control of the conduct of Contractor or any of the Contractor's employees, except as herein set forth. Contractor shall not at any time or in any manner represent that it or any of its agents or employees are in any manner agents or employees of City.
10. Contractor and Subcontractor Registration. Effective March 1, 2015, pursuant to Labor Code sections 1725.5 and 1771.1, all contractors and subcontractors that wish to bid on, be listed in a bid proposal, or enter into a contract to perform public works must be registered with the Department of Industrial Relations. No bid will be accepted nor any contract entered into without proof of the contractor's and subcontractors' current registration with the Department of Industrial Relations to perform public work. Contractor is directed to review, fill out and execute the Public Works Contractor Registration Certification contained in the Bid Proposal prior to contract execution.
11. Notices. All notices and communications shall be sent to the parties at the following addresses:

CITY:	City Engineer City of Lafayette 3675 Mount Diablo Boulevard, Suite 210 Lafayette, California 94549
CONTRACTOR:	_____ _____ _____ _____
12. Authorized Signature. Contractor affirms that the signatures, titles, and seals set forth hereinafter in execution of this contract agreement represent all individuals, firm members, partners, joint ventures, and/or corporate officers having a principal interest herein.

13. Entire Agreement; Modification. This contract supersedes any and all other agreements either oral or written, between the parties and contains all of the covenants and agreements between the parties pertaining to the work of improvements described in Paragraph A of the Recitals herein above. Each party to this contract acknowledges that no representations, inducements, promises, or agreements, orally or otherwise, have been made by any party, or anyone acting on behalf of any party, which are not embodied herein, and that any other agreement, statements or promise not contained in this contract shall not be valid or binding. Any modification of this contract will be effective only if signed by the party to be charged.
14. Claims Procedure. In the event of a dispute between the parties regarding a) a time extension demand, b) payment arising for work performed by or on behalf of the contractor which is not otherwise expressly provided for, or c) an amount the payment of which is disputed by the City, the procedure in Section 10 of the City of Lafayette Standard Specifications shall be used.

TITLE VI ASSURANCES

During the performance of this Agreement, the contractor, for itself, its assignees and successors in interest (hereinafter collectively referred to as CONTRACTOR) agrees as follows:

- (1) Compliance with Regulations: CONTRACTOR shall comply with the regulations relative to nondiscrimination in federally assisted programs of the Department of Transportation, Title 49, Code of Federal Regulations, Part 21, as they may be amended from time to time, (hereinafter referred to as the REGULATIONS), which are herein incorporated by reference and made a part of this agreement.
- (2) Nondiscrimination: CONTRACTOR, with regard to the work performed by it during the AGREEMENT, shall not discriminate on the grounds of race, color, sex, national origin, religion, age, or disability in the selection and retention of sub-applicants, including procurements of materials and leases of equipment. CONTRACTOR shall not participate either directly or indirectly in the discrimination prohibited by Section 21.5 of the Regulations, including employment practices when the agreement covers a program set forth in Appendix B of the Regulations.
- (3) Solicitations for Sub-agreements, Including Procurements of Materials and Equipment: In all solicitations either by competitive bidding or negotiation made by CONTRACTOR for work to be performed under a Sub-agreement, including procurements of materials or leases of equipment, each potential sub-applicant or supplier shall be notified by CONTRACTOR of the CONTRACTOR'S obligations under this Agreement and the Regulations relative to nondiscrimination on the grounds of race, color, or national origin.
- (4) Information and Reports: CONTRACTOR shall provide all information and reports required by the Regulations, or directives issued pursuant thereto, and shall permit access to its books, records, accounts, other sources of information, and its facilities as may be determined by the California Department of Transportation or FHWA to be pertinent to ascertain compliance with such Regulations or directives. Where any information required of CONTRACTOR is in the exclusive possession of another who fails or refuses to furnish this information, CONTRACTOR shall so certify to the California Department of Transportation or the FHWA as appropriate, and shall set forth what efforts CONTRACTOR has made to obtain the information.
- (5) Sanctions for Noncompliance: In the event of CONTRACTOR's noncompliance with the nondiscrimination provisions of this agreement, the California Department of Transportation shall impose such agreement sanctions as it or the FHWA may determine to be appropriate, including, but not limited to:
 - (a) withholding of payments to CONTRACTOR under the Agreement within a reasonable period of time, not to exceed 90 days; and/or
 - (b) cancellation, termination or suspension of the Agreement, in whole or in part.

- (6) Incorporation of Provisions: CONTRACTOR shall include the provisions of paragraphs (1) through (6) in every sub-agreement, including procurements of materials and leases of equipment, unless exempt by the Regulations, or directives issued pursuant thereto.

CONTRACTOR shall take such action with respect to any sub-agreement or procurement as the California Department of Transportation or FHWA may direct as a means of enforcing such provisions including sanctions for noncompliance, provided, however, that, in the event CONTRACTOR becomes involved in, or is threatened with, litigation with a sub-applicant or supplier as a result of such direction, CONTRACTOR may request the California Department of Transportation enter into such litigation to protect the interests of the State, and, in addition, CONTRACTOR may request the United States to enter into such litigation to protect the interests of the United States.

**REQUIRED CONTRACT PROVISIONS for
FEDERAL-AID CONSTRUCTION CONTRACTS
(Form FHWA-1273)**

Contractor shall maintain records and, when directed to do so, submit reports documenting its performance of provisions of this section.

- I. General
- II. Nondiscrimination
- III. Nonsegregated Facilities
- IV. Davis-Bacon and Related Act Provisions
- V. Contract Work Hours and Safety Standards Act Provisions
- VI. Subletting or Assigning the Contract
- VII. Safety: Accident Prevention
- VIII. False Statements Concerning Highway Projects
- IX. Implementation of Clean Air Act and Federal Water Pollution Control Act
- X. Compliance with Government wide Suspension and Debarment Requirements
- XI. Certification Regarding Use of Contract Funds for Lobbying

I. GENERAL

1. Form FHWA-1273 must be physically incorporated in each construction contract funded under Title 23 (excluding emergency contracts solely intended for debris removal). The contractor (or subcontractor) must insert this form in each subcontract and further require its inclusion in all lower tier subcontracts (excluding purchase orders, rental agreements and other agreements for supplies or services).

The applicable requirements of Form FHWA-1273 are incorporated by reference for work done under any purchase order, rental agreement or agreement for other services. The prime contractor shall be responsible for compliance by any subcontractor, lower-tier subcontractor or service provider.

Form FHWA-1273 must be included in all Federal-aid design-build contracts, in all subcontracts and in lower tier subcontracts (excluding subcontracts for design services, purchase orders, rental agreements and other agreements for supplies or services). The design-builder shall be responsible for compliance by any subcontractor, lower-tier subcontractor or service provider.

Contracting agencies may reference Form FHWA-1273 in bid proposal or request for proposal documents, however, the Form FHWA-1273 must be physically incorporated (not referenced) in all contracts, subcontracts and lower-tier subcontracts (excluding purchase orders, rental agreements and other agreements for supplies or services related to a construction contract).

2. Subject to the applicability criteria noted in the following sections, these contract provisions shall apply to all work performed on the contract by the contractor's own organization and with the assistance of workers under the contractor's immediate superintendence and to all work performed on the contract by piecework, station work, or by subcontract.
3. A breach of any of the stipulations contained in these Required Contract Provisions may be sufficient grounds for withholding of progress payments, withholding of final payment, termination of the contract, suspension / debarment or any other action determined to be appropriate by the contracting agency and FHWA.
4. Selection of Labor: During the performance of this contract, the contractor shall not use convict labor for any purpose within the limits of a construction project on a Federal-aid highway unless it is labor performed by convicts who are on parole, supervised release, or probation. The term Federal-aid highway does not include roadways functionally classified as local roads or rural minor collectors.

II. NONDISCRIMINATION

The provisions of this section related to 23 CFR Part 230 are applicable to all Federal-aid construction contracts and to all related construction subcontracts of \$10,000 or more. The provisions of 23 CFR Part 230 are not applicable to material supply, engineering, or architectural service contracts.

In addition, the contractor and all subcontractors must comply with the following policies: Executive Order 11246, 41 CFR 60, 29 CFR 1625-1627, Title 23 USC Section 140, the Rehabilitation Act of 1973, as amended (29 USC 794), Title VI of the Civil Rights Act of 1964, as amended, and related regulations including 49 CFR Parts 21, 26 and 27; and 23 CFR Parts 200, 230, and 633.

The contractor and all subcontractors must comply with: the requirements of the Equal Opportunity Clause in 41 CFR 60-1.4(b) and, for all construction contracts exceeding \$10,000, the Standard Federal Equal Employment Opportunity Construction Contract Specifications in 41 CFR 60-4.3.

Note: The U.S. Department of Labor has exclusive authority to determine compliance with Executive Order 11246 and the policies of the Secretary of Labor including 41 CFR 60, and 29 CFR 1625-1627. The contracting agency and the FHWA have the authority and the responsibility to ensure compliance with Title 23 USC Section 140, the Rehabilitation Act of 1973, as amended (29 USC 794), and Title VI of the Civil Rights Act of 1964, as amended, and related regulations including 49 CFR Parts 21, 26 and 27; and 23 CFR Parts 200, 230, and 633.

The following provision is adopted from 23 CFR 230, Appendix A, with appropriate revisions to conform to the U.S. Department of Labor (US DOL) and FHWA requirements.

1. **Equal Employment Opportunity:** Equal employment opportunity (EEO) requirements not to discriminate and to take affirmative action to assure equal opportunity as set forth under laws, executive orders, rules, regulations (28 CFR 35, 29 CFR 1630, 29 CFR 1625-1627, 41 CFR 60 and 49 CFR 27) and orders of the Secretary of Labor as modified by the provisions prescribed herein, and imposed pursuant to 23 U.S.C. 140 shall constitute the EEO and specific affirmative action standards for the contractor's project activities under this contract. The provisions of the Americans with Disabilities Act of 1990 (42 U.S.C. 12101 et seq.) set forth under 28 CFR 35 and 29 CFR 1630 are incorporated by reference in this contract. In the execution of this contract, the contractor agrees to comply with the following minimum specific requirement activities of EEO:

- c. The contractor will work with the contracting agency and the Federal Government to ensure that it has made every good faith effort to provide equal opportunity with respect to all of its terms and conditions of employment and in their review of activities under the contract.
 - d. The contractor will accept as its operating policy the following statement:
"It is the policy of this Company to assure that applicants are employed, and that employees are treated during employment, without regard to their race, religion, sex, color, national origin, age or disability. Such action shall include: employment, upgrading, demotion, or transfer; recruitment or recruitment advertising; layoff or termination; rates of pay or other forms of compensation; and selection for training, including apprenticeship, pre-apprenticeship, and/or on-the-job training."
2. **EEO Officer:** The contractor will designate and make known to the contracting officers an EEO Officer who will have the responsibility for and must be capable of effectively administering and promoting an active EEO program and who must be assigned adequate authority and responsibility to do so.
3. **Dissemination of Policy:** All members of the contractor's staff who are authorized to hire, supervise, promote, and discharge employees, or who recommend such action, or who are substantially involved in such action, will be made fully cognizant of, and will implement, the contractor's EEO policy and contractual responsibilities to provide EEO in each grade and classification of employment. To ensure that the above agreement will be met, the following actions will be taken as a minimum:
- a. Periodic meetings of supervisory and personnel office employees will be conducted before the start of work and then not less often than once every six months, at which time the contractor's EEO policy and its implementation will be reviewed and explained. The meetings will be conducted by the EEO Officer.
 - b. All new supervisory or personnel office employees will be given a thorough indoctrination by the EEO Officer, covering all major aspects of the contractor's EEO obligations within thirty days following their reporting for duty with the contractor.
 - c. All personnel who are engaged in direct recruitment for the project will be instructed by the EEO Officer in the contractor's procedures for locating and hiring minorities and women.
 - d. Notices and posters setting forth the contractor's EEO policy will be placed in areas readily accessible to employees, applicants for employment and potential employees.
 - e. The contractor's EEO policy and the procedures to implement such policy will be brought to the attention of employees by means of meetings, employee handbooks, or other appropriate means.
4. **Recruitment:** When advertising for employees, the contractor will include in all advertisements for employees the notation: "An Equal Opportunity Employer." All such advertisements will be placed in publications having a large circulation among minorities and women in the area from which the project work force would normally be derived.
- a. The contractor will, unless precluded by a valid bargaining agreement, conduct systematic and direct recruitment through public and private employee referral sources likely to yield qualified minorities and women. To meet this requirement, the contractor will identify sources of potential minority group employees, and establish with such identified sources procedures whereby minority and women applicants may be referred to the contractor for employment consideration.

- b. In the event the contractor has a valid bargaining agreement providing for exclusive hiring hall referrals, the contractor is expected to observe the provisions of that agreement to the extent that the system meets the contractor's compliance with EEO contract provisions. Where implementation of such an agreement has the effect of discriminating against minorities or women, or obligates the contractor to do the same, such implementation violates Federal nondiscrimination provisions.
 - c. The contractor will encourage its present employees to refer minorities and women as applicants for employment. Information and procedures with regard to referring such applicants will be discussed with employees.
- 5. Personnel Actions:** Wages, working conditions, and employee benefits shall be established and administered, and personnel actions of every type, including hiring, upgrading, promotion, transfer, demotion, layoff, and termination, shall be taken without regard to race, color, religion, sex, national origin, age or disability. The following procedures shall be followed:
- a. The contractor will conduct periodic inspections of project sites to insure that working conditions and employee facilities do not indicate discriminatory treatment of project site personnel.
 - b. The contractor will periodically evaluate the spread of wages paid within each classification to determine any evidence of discriminatory wage practices.
 - c. The contractor will periodically review selected personnel actions in depth to determine whether there is evidence of discrimination. Where evidence is found, the contractor will promptly take corrective action. If the review indicates that the discrimination may extend beyond the actions reviewed, such corrective action shall include all affected persons.
 - d. The contractor will promptly investigate all complaints of alleged discrimination made to the contractor in connection with its obligations under this contract, will attempt to resolve such complaints, and will take appropriate corrective action within a reasonable time. If the investigation indicates that the discrimination may affect persons other than the complainant, such corrective action shall include such other persons. Upon completion of each investigation, the contractor will inform every complainant of all of their avenues of appeal.
- 6. Training and Promotion:**
- a. The contractor will assist in locating, qualifying, and increasing the skills of minorities and women who are applicants for employment or current employees. Such efforts should be aimed at developing full journey level status employees in the type of trade or job classification involved.
 - e. Consistent with the contractor's work force requirements and as permissible under Federal and State regulations, the contractor shall make full use of training programs, i.e., apprenticeship, and on-the-job training programs for the geographical area of contract performance. In the event a special provision for training is provided under this contract, this subparagraph will be superseded as indicated in the special provision. The contracting agency may reserve training positions for persons who receive welfare assistance in accordance with 23 U.S.C. 140(a).
 - f. The contractor will advise employees and applicants for employment of available training programs and entrance requirements for each.

10. Assurance Required by 49 CFR 26.13(b):

- a. The requirements of 49 CFR Part 26 and the State DOT's U.S. DOT-approved DBE program are incorporated by reference.
- b. The contractor or subcontractor shall not discriminate on the basis of race, color, national origin, or sex in the performance of this contract. The contractor shall carry out applicable requirements of 49 CFR Part 26 in the award and administration of DOT-assisted contracts. Failure by the contractor to carry out these requirements is a material breach of this contract, which may result in the termination of this contract or such other remedy as the contracting agency deems appropriate.

11. Records and Reports: The contractor shall keep such records as necessary to document compliance with the EEO requirements. Such records shall be retained for a period of three years following the date of the final payment to the contractor for all contract work and shall be available at reasonable times and places for inspection by authorized representatives of the contracting agency and the FHWA.

- a. The records kept by the contractor shall document the following:
 - (1) The number and work hours of minority and non-minority group members and women employed in each work classification on the project;
 - (2) The progress and efforts being made in cooperation with unions, when applicable, to increase employment opportunities for minorities and women; and
 - (3) The progress and efforts being made in locating, hiring, training, qualifying, and upgrading minorities and women;
- b. The contractors and subcontractors will submit an annual report to the contracting agency each July for the duration of the project, indicating the number of minority, women, and non-minority group employees currently engaged in each work classification required by the contract work. This information is to be reported on Form FHWA-1391. The staffing data should represent the project work force on board in all or any part of the last payroll period preceding the end of July. If on-the-job training is being required by special provision, the contractor will be required to collect and report training data. The employment data should reflect the work force on board during all or any part of the last payroll period preceding the end of July.

III. NONSEGREGATED FACILITIES

This provision is applicable to all Federal-aid construction contracts and to all related construction subcontracts of \$10,000 or more.

The contractor must ensure that facilities provided for employees are provided in such a manner that segregation on the basis of race, color, religion, sex, or national origin cannot result. The contractor may neither require such segregated use by written or oral policies nor tolerate such use by employee custom. The contractor's obligation extends further to ensure that its employees are not assigned to perform their services at any location, under the contractor's control, where the facilities are segregated. The term "facilities" includes waiting rooms, work areas, restaurants and other eating areas, time clocks, restrooms, washrooms, locker rooms, and other storage or dressing areas, parking lots, drinking fountains, recreation or entertainment areas, transportation, and housing provided for employees. The contractor shall provide

separate or single-user restrooms and necessary dressing or sleeping areas to assure privacy between sexes.

IV. DAVIS-BACON AND RELATED ACT PROVISIONS

This section is applicable to all Federal-aid construction projects exceeding \$2,000 and to all related subcontracts and lower-tier subcontracts (regardless of subcontract size). The requirements apply to all projects located within the right-of-way of a roadway that is functionally classified as Federal-aid highway. This excludes roadways functionally classified as local roads or rural minor collectors, which are exempt. Contracting agencies may elect to apply these requirements to other projects.

The following provisions are from the U.S. Department of Labor regulations in 29 CFR 5.5 "Contract provisions and related matters" with minor revisions to conform to the FHWA-1273 format and FHWA program requirements.

1. Minimum wages

- a. All laborers and mechanics employed or working upon the site of the work, will be paid unconditionally and not less often than once a week, and without subsequent deduction or rebate on any account (except such payroll deductions as are permitted by regulations issued by the Secretary of Labor under the Copeland Act (29 CFR part 3)), the full amount of wages and bona fide fringe benefits (or cash equivalents thereof) due at time of payment computed at rates not less than those contained in the wage determination of the Secretary of Labor which is attached hereto and made a part hereof, regardless of any contractual relationship which may be alleged to exist between the contractor and such laborers and mechanics.

Contributions made or costs reasonably anticipated for bona fide fringe benefits under section 1(b)(2) of the Davis-Bacon Act on behalf of laborers or mechanics are considered wages paid to such laborers or mechanics, subject to the provisions of paragraph 1.d. of this section; also, regular contributions made or costs incurred for more than a weekly period (but not less often than quarterly) under plans, funds, or programs which cover the particular weekly period, are deemed to be constructively made or incurred during such weekly period. Such laborers and mechanics shall be paid the appropriate wage rate and fringe benefits on the wage determination for the classification of work actually performed, without regard to skill, except as provided in 29 CFR 5.5(a)(4). Laborers or mechanics performing work in more than one classification may be compensated at the rate specified for each classification for the time actually worked therein: Provided, That the employer's payroll records accurately set forth the time spent in each classification in which work is performed. The wage determination (including any additional classification and wage rates conformed under paragraph 1.b. of this section) and the Davis-Bacon poster (WH-1321) shall be posted at all times by the contractor and its subcontractors at the site of the work in a prominent and accessible place where it can be easily seen by the workers.

- b. (1) The contracting officer shall require that any class of laborers or mechanics, including helpers, which is not listed in the wage determination and which is to be employed under the contract shall be classified in conformance with the wage determination. The contracting officer shall approve an additional classification and wage rate and fringe benefits therefore only when the following criteria have been met:
 - (i) The work to be performed by the classification requested is not performed by a classification in the wage determination; and
 - (ii) The classification is utilized in the area by the construction industry; and

- (iii) The proposed wage rate, including any bona fide fringe benefits, bears a reasonable relationship to the wage rates contained in the wage determination.
 - (2) If the contractor and the laborers and mechanics to be employed in the classification (if known), or their representatives, and the contracting officer agree on the classification and wage rate (including the amount designated for fringe benefits where appropriate), a report of the action taken shall be sent by the contracting officer to the Administrator of the Wage and Hour Division, Employment Standards Administration, U.S. Department of Labor, Washington, DC 20210. The Administrator, or an authorized representative, will approve, modify, or disapprove every additional classification action within 30 days of receipt and so advise the contracting officer or will notify the contracting officer within the 30-day period that additional time is necessary.
 - (3) In the event the contractor, the laborers or mechanics to be employed in the classification or their representatives, and the contracting officer do not agree on the proposed classification and wage rate (including the amount designated for fringe benefits, where appropriate), the contracting officer shall refer the questions, including the views of all interested parties and the recommendation of the contracting officer, to the Wage and Hour Administrator for determination. The Wage and Hour Administrator, or an authorized representative, will issue a determination within 30 days of receipt and so advise the contracting officer or will notify the contracting officer within the 30-day period that additional time is necessary.
 - (4) The wage rate (including fringe benefits where appropriate) determined pursuant to paragraphs 1.b.(2) or 1.b.(3) of this section, shall be paid to all workers performing work in the classification under this contract from the first day on which work is performed in the classification.
- c. Whenever the minimum wage rate prescribed in the contract for a class of laborers or mechanics includes a fringe benefit which is not expressed as an hourly rate, the contractor shall either pay the benefit as stated in the wage determination or shall pay another bona fide fringe benefit or an hourly cash equivalent thereof.
- d. If the contractor does not make payments to a trustee or other third person, the contractor may consider as part of the wages of any laborer or mechanic the amount of any costs reasonably anticipated in providing bona fide fringe benefits under a plan or program, Provided, That the Secretary of Labor has found, upon the written request of the contractor, that the applicable standards of the Davis-Bacon Act have been met. The Secretary of Labor may require the contractor to set aside in a separate account assets for the meeting of obligations under the plan or program.

2. Withholding

The contracting agency shall upon its own action or upon written request of an authorized representative of the Department of Labor, withhold or cause to be withheld from the contractor under this contract, or any other Federal contract with the same prime contractor, or any other federally-assisted contract subject to Davis-Bacon prevailing wage requirements, which is held by the same prime contractor, so much of the accrued payments or advances as may be considered necessary to pay laborers and mechanics, including apprentices, trainees, and helpers, employed by the contractor or any subcontractor the full amount of wages required by the contract. In the event of failure to pay any laborer or mechanic, including any apprentice, trainee, or helper, employed or working on the site of the work, all or part of the wages required by the contract, the contracting agency may, after written notice to the contractor, take such action as may be necessary to cause the suspension of any further payment, advance, or guarantee of funds until such violations have ceased.

3. Payrolls and basic records

- a. Payrolls and basic records relating thereto shall be maintained by the contractor during the course of the work and preserved for a period of three years thereafter for all laborers and mechanics working at the site of the work. Such records shall contain the name, address, and social security number of each such worker, his or her correct classification, hourly rates of wages paid (including rates of contributions or costs anticipated for bona fide fringe benefits or cash equivalents thereof of the types described in section 1(b)(2)(B) of the Davis-Bacon Act), daily and weekly number of hours worked, deductions made and actual wages paid. Whenever the Secretary of Labor has found under 29 CFR 5.5(a)(1)(iv) that the wages of any laborer or mechanic include the amount of any costs reasonably anticipated in providing benefits under a plan or program described in section 1(b)(2)(B) of the Davis-Bacon Act, the contractor shall maintain records which show that the commitment to provide such benefits is enforceable, that the plan or program is financially responsible, and that the plan or program has been communicated in writing to the laborers or mechanics affected, and records which show the costs anticipated or the actual cost incurred in providing such benefits. Contractors employing apprentices or trainees under approved programs shall maintain written evidence of the registration of apprenticeship programs and certification of trainee programs, the registration of the apprentices and trainees, and the ratios and wage rates prescribed in the applicable programs.
- b. (1) The contractor shall submit weekly for each week in which any contract work is performed a copy of all payrolls to the contracting agency. The payrolls submitted shall set out accurately and completely all of the information required to be maintained under 29 CFR 5.5(a)(3)(i), except that full social security numbers and home addresses shall not be included on weekly transmittals. Instead the payrolls shall only need to include an individually identifying number for each employee (e.g. , the last four digits of the employee's social security number). The required weekly payroll information may be submitted in any form desired. Optional Form WH-347 is available for this purpose from the Wage and Hour Division Web site at <http://www.dol.gov/esa/whd/forms/wh347instr.htm> or its successor site. The prime contractor is responsible for the submission of copies of payrolls by all subcontractors. Contractors and subcontractors shall maintain the full social security number and current address of each covered worker, and shall provide them upon request to the contracting agency for transmission to the State DOT, the FHWA or the Wage and Hour Division of the Department of Labor for purposes of an investigation or audit of compliance with prevailing wage requirements. It is not a violation of this section for a prime contractor to require a subcontractor to provide addresses and social security numbers to the prime contractor for its own records, without weekly submission to the contracting agency..
- (2) Each payroll submitted shall be accompanied by a "Statement of Compliance," signed by the contractor or subcontractor or his or her agent who pays or supervises the payment of the persons employed under the contract and shall certify the following:
 - (i) That the payroll for the payroll period contains the information required to be provided under §5.5 (a)(3)(ii) of Regulations, 29 CFR part 5, the appropriate information is being maintained under §5.5 (a)(3)(i) of Regulations, 29 CFR part 5, and that such information is correct and complete;
 - (ii) That each laborer or mechanic (including each helper, apprentice, and trainee) employed on the contract during the payroll period has been paid the full weekly wages earned, without rebate, either directly or indirectly, and that no deductions have been made either directly or indirectly from the full wages earned, other than permissible deductions as set forth in Regulations, 29 CFR part 3;

- (iii) That each laborer or mechanic has been paid not less than the applicable wage rates and fringe benefits or cash equivalents for the classification of work performed, as specified in the applicable wage determination incorporated into the contract.
 - (3) The weekly submission of a properly executed certification set forth on the reverse side of Optional Form WH-347 shall satisfy the requirement for submission of the "Statement of Compliance" required by paragraph 3.b.(2) of this section.
 - (4) The falsification of any of the above certifications may subject the contractor or subcontractor to civil or criminal prosecution under section 1001 of title 18 and section 231 of title 31 of the United States Code.
- c. The contractor or subcontractor shall make the records required under paragraph 3.a. of this section available for inspection, copying, or transcription by authorized representatives of the contracting agency, the State DOT, the FHWA, or the Department of Labor, and shall permit such representatives to interview employees during working hours on the job. If the contractor or subcontractor fails to submit the required records or to make them available, the FHWA may, after written notice to the contractor, the contracting agency or the State DOT, take such action as may be necessary to cause the suspension of any further payment, advance, or guarantee of funds. Furthermore, failure to submit the required records upon request or to make such records available may be grounds for debarment action pursuant to 29 CFR 5.12.

4. Apprentices and trainees

- a. Apprentices (programs of the USDOL).

Apprentices will be permitted to work at less than the predetermined rate for the work they performed when they are employed pursuant to and individually registered in a bona fide apprenticeship program registered with the U.S. Department of Labor, Employment and Training Administration, Office of Apprenticeship Training, Employer and Labor Services, or with a State Apprenticeship Agency recognized by the Office, or if a person is employed in his or her first 90 days of probationary employment as an apprentice in such an apprenticeship program, who is not individually registered in the program, but who has been certified by the Office of Apprenticeship Training, Employer and Labor Services or a State Apprenticeship Agency (where appropriate) to be eligible for probationary employment as an apprentice.

The allowable ratio of apprentices to journeymen on the job site in any craft classification shall not be greater than the ratio permitted to the contractor as to the entire work force under the registered program. Any worker listed on a payroll at an apprentice wage rate, who is not registered or otherwise employed as stated above, shall be paid not less than the applicable wage rate on the wage determination for the classification of work actually performed. In addition, any apprentice performing work on the job site in excess of the ratio permitted under the registered program shall be paid not less than the applicable wage rate on the wage determination for the work actually performed. Where a contractor is performing construction on a project in a locality other than that in which its program is registered, the ratios and wage rates (expressed in percentages of the journeyman's hourly rate) specified in the contractor's or subcontractor's registered program shall be observed.

Every apprentice must be paid at not less than the rate specified in the registered program for the apprentice's level of progress, expressed as a percentage of the journeymen hourly rate specified in the applicable wage determination. Apprentices shall be paid fringe benefits in accordance with the provisions of the apprenticeship program. If the apprenticeship program does not specify fringe benefits, apprentices must be paid the full amount of fringe benefits listed on the wage

determination for the applicable classification. If the Administrator determines that a different practice prevails for the applicable apprentice classification, fringes shall be paid in accordance with that determination.

In the event the Office of Apprenticeship Training, Employer and Labor Services, or a State Apprenticeship Agency recognized by the Office, withdraws approval of an apprenticeship program, the contractor will no longer be permitted to utilize apprentices at less than the applicable predetermined rate for the work performed until an acceptable program is approved.

b. Trainees (programs of the USDOL).

Except as provided in 29 CFR 5.16, trainees will not be permitted to work at less than the predetermined rate for the work performed unless they are employed pursuant to and individually registered in a program which has received prior approval, evidenced by formal certification by the U.S. Department of Labor, Employment and Training Administration.

The ratio of trainees to journeymen on the job site shall not be greater than permitted under the plan approved by the Employment and Training Administration.

Every trainee must be paid at not less than the rate specified in the approved program for the trainee's level of progress, expressed as a percentage of the journeyman hourly rate specified in the applicable wage determination. Trainees shall be paid fringe benefits in accordance with the provisions of the trainee program. If the trainee program does not mention fringe benefits, trainees shall be paid the full amount of fringe benefits listed on the wage determination unless the Administrator of the Wage and Hour Division determines that there is an apprenticeship program associated with the corresponding journeyman wage rate on the wage determination which provides for less than full fringe benefits for apprentices. Any employee listed on the payroll at a trainee rate who is not registered and participating in a training plan approved by the Employment and Training Administration shall be paid not less than the applicable wage rate on the wage determination for the classification of work actually performed. In addition, any trainee performing work on the job site in excess of the ratio permitted under the registered program shall be paid not less than the applicable wage rate on the wage determination for the work actually performed.

In the event the Employment and Training Administration withdraws approval of a training program, the contractor will no longer be permitted to utilize trainees at less than the applicable predetermined rate for the work performed until an acceptable program is approved.

c. Equal employment opportunity. The utilization of apprentices, trainees and journeymen under this part shall be in conformity with the equal employment opportunity requirements of Executive Order 11246, as amended, and 29 CFR part 30.

d. Apprentices and Trainees (programs of the U.S. DOT).

Apprentices and trainees working under apprenticeship and skill training programs which have been certified by the Secretary of Transportation as promoting EEO in connection with Federal-aid highway construction programs are not subject to the requirements of paragraph 4 of this Section IV. The straight time hourly wage rates for apprentices and trainees under such programs will be established by the particular programs. The ratio of apprentices and trainees to journeymen shall not be greater than permitted by the terms of the particular program.

5. Compliance with Copeland Act requirements. The contractor shall comply with the requirements of 29 CFR part 3, which are incorporated by reference in this contract.

6. **Subcontracts.** The contractor or subcontractor shall insert Form FHWA-1273 in any subcontracts and also require the subcontractors to include Form FHWA-1273 in any lower tier subcontracts. The prime contractor shall be responsible for the compliance by any subcontractor or lower tier subcontractor with all the contract clauses in 29 CFR 5.5.
7. **Contract termination: debarment.** A breach of the contract clauses in 29 CFR 5.5 may be grounds for termination of the contract, and for debarment as a contractor and a subcontractor as provided in 29 CFR 5.12.
8. **Compliance with Davis-Bacon and Related Act requirements.** All rulings and interpretations of the Davis-Bacon and Related Acts contained in 29 CFR parts 1, 3, and 5 are herein incorporated by reference in this contract.
9. **Disputes concerning labor standards.** Disputes arising out of the labor standards provisions of this contract shall not be subject to the general disputes clause of this contract. Such disputes shall be resolved in accordance with the procedures of the Department of Labor set forth in 29 CFR parts 5, 6, and 7. Disputes within the meaning of this clause include disputes between the contractor (or any of its subcontractors) and the contracting agency, the U.S. Department of Labor, or the employees or their representatives.
10. **Certification of eligibility.**
 - a. By entering into this contract, the contractor certifies that neither it (nor he or she) nor any person or firm who has an interest in the contractor's firm is a person or firm ineligible to be awarded Government contracts by virtue of section 3(a) of the Davis-Bacon Act or 29 CFR 5.12(a)(1).
 - b. No part of this contract shall be subcontracted to any person or firm ineligible for award of a Government contract by virtue of section 3(a) of the Davis-Bacon Act or 29 CFR 5.12(a)(1).
 - c. The penalty for making false statements is prescribed in the U.S. Criminal Code, 18 U.S.C. 1001.

V. CONTRACT WORK HOURS AND SAFETY STANDARDS ACT

The following clauses apply to any Federal-aid construction contract in an amount in excess of \$100,000 and subject to the overtime provisions of the Contract Work Hours and Safety Standards Act. These clauses shall be inserted in addition to the clauses required by 29 CFR 5.5(a) or 29 CFR 4.6. As used in this paragraph, the terms laborers and mechanics include watchmen and guards.

1. **Overtime requirements.** No contractor or subcontractor contracting for any part of the contract work which may require or involve the employment of laborers or mechanics shall require or permit any such laborer or mechanic in any workweek in which he or she is employed on such work to work in excess of forty hours in such workweek unless such laborer or mechanic receives compensation at a rate not less than one and one-half times the basic rate of pay for all hours worked in excess of forty hours in such workweek.
2. **Violation; liability for unpaid wages; liquidated damages.** In the event of any violation of the clause set forth in paragraph (1.) of this section, the contractor and any subcontractor responsible therefor shall be liable for the unpaid wages. In addition, such contractor and subcontractor shall be liable to the United States (in the case of work done under contract for the District of Columbia or a territory, to such District or to such territory), for liquidated damages. Such liquidated damages shall be computed with respect to each individual laborer or mechanic, including watchmen and guards, employed in violation of the clause set forth in paragraph (1.) of this section, in the sum of \$10 for each calendar day on which such individual was required or permitted to work in excess of the standard workweek of forty

hours without payment of the overtime wages required by the clause set forth in paragraph (1.) of this section.

3. **Withholding for unpaid wages and liquidated damages.** The FHWA or the contacting agency shall upon its own action or upon written request of an authorized representative of the Department of Labor withhold or cause to be withheld, from any moneys payable on account of work performed by the contractor or subcontractor under any such contract or any other Federal contract with the same prime contractor, or any other federally-assisted contract subject to the Contract Work Hours and Safety Standards Act, which is held by the same prime contractor, such sums as may be determined to be necessary to satisfy any liabilities of such contractor or subcontractor for unpaid wages and liquidated damages as provided in the clause set forth in paragraph (2.) of this section.
4. **Subcontracts.** The contractor or subcontractor shall insert in any subcontracts the clauses set forth in paragraph (1.) through (4.) of this section and also a clause requiring the subcontractors to include these clauses in any lower tier subcontracts. The prime contractor shall be responsible for compliance by any subcontractor or lower tier subcontractor with the clauses set forth in paragraphs (1.) through (4.) of this section.

VI. SUBLETTING OR ASSIGNING THE CONTRACT

This provision is applicable to all Federal-aid construction contracts on the National Highway System.

1. The contractor shall perform with its own organization contract work amounting to not less than 30 percent (or a greater percentage if specified elsewhere in the contract) of the total original contract price, excluding any specialty items designated by the contracting agency. Specialty items may be performed by subcontract and the amount of any such specialty items performed may be deducted from the total original contract price before computing the amount of work required to be performed by the contractor's own organization (23 CFR 635.116).
 - a. The term "perform work with its own organization" refers to workers employed or leased by the prime contractor, and equipment owned or rented by the prime contractor, with or without operators. Such term does not include employees or equipment of a subcontractor or lower tier subcontractor, agents of the prime contractor, or any other assignees. The term may include payments for the costs of hiring leased employees from an employee leasing firm meeting all relevant Federal and State regulatory requirements. Leased employees may only be included in this term if the prime contractor meets all of the following conditions:
 - (1) the prime contractor maintains control over the supervision of the day-to-day activities of the leased employees;
 - (2) the prime contractor remains responsible for the quality of the work of the leased employees;
 - (3) the prime contractor retains all power to accept or exclude individual employees from work on the project; and
 - (4) the prime contractor remains ultimately responsible for the payment of predetermined minimum wages, the submission of payrolls, statements of compliance and all other Federal regulatory requirements.
 - b. "Specialty Items" shall be construed to be limited to work that requires highly specialized knowledge, abilities, or equipment not ordinarily available in the type of contracting organizations qualified and expected to bid or propose on the contract as a whole and in general are to be limited to minor components of the overall contract.

2. The contract amount upon which the requirements set forth in paragraph (1) of Section VI is computed includes the cost of material and manufactured products which are to be purchased or produced by the contractor under the contract provisions.
3. The contractor shall furnish (a) a competent superintendent or supervisor who is employed by the firm, has full authority to direct performance of the work in accordance with the contract requirements, and is in charge of all construction operations (regardless of who performs the work) and (b) such other of its own organizational resources (supervision, management, and engineering services) as the contracting officer determines is necessary to assure the performance of the contract.
4. No portion of the contract shall be sublet, assigned or otherwise disposed of except with the written consent of the contracting officer, or authorized representative, and such consent when given shall not be construed to relieve the contractor of any responsibility for the fulfillment of the contract. Written consent will be given only after the contracting agency has assured that each subcontract is evidenced in writing and that it contains all pertinent provisions and requirements of the prime contract.
5. The 30% self-performance requirement of paragraph (1) is not applicable to design-build contracts; however, contracting agencies may establish their own self-performance requirements.

VII. SAFETY: ACCIDENT PREVENTION

This provision is applicable to all Federal-aid construction contracts and to all related subcontracts.

1. In the performance of this contract the contractor shall comply with all applicable Federal, State, and local laws governing safety, health, and sanitation (23 CFR 635). The contractor shall provide all safeguards, safety devices and protective equipment and take any other needed actions as it determines, or as the contracting officer may determine, to be reasonably necessary to protect the life and health of employees on the job and the safety of the public and to protect property in connection with the performance of the work covered by the contract.
2. It is a condition of this contract, and shall be made a condition of each subcontract, which the contractor enters into pursuant to this contract, that the contractor and any subcontractor shall not permit any employee, in performance of the contract, to work in surroundings or under conditions which are unsanitary, hazardous or dangerous to his/her health or safety, as determined under construction safety and health standards (29 CFR 1926) promulgated by the Secretary of Labor, in accordance with Section 107 of the Contract Work Hours and Safety Standards Act (40 U.S.C. 3704).
3. Pursuant to 29 CFR 1926.3, it is a condition of this contract that the Secretary of Labor or authorized representative thereof, shall have right of entry to any site of contract performance to inspect or investigate the matter of compliance with the construction safety and health standards and to carry out the duties of the Secretary under Section 107 of the Contract Work Hours and Safety Standards Act (40 U.S.C.3704).

VIII. FALSE STATEMENTS CONCERNING HIGHWAY PROJECTS

This provision is applicable to all Federal-aid construction contracts and to all related subcontracts.

In order to assure high quality and durable construction in conformity with approved plans and specifications and a high degree of reliability on statements and representations made by engineers, contractors, suppliers, and workers on Federal-aid highway projects, it is essential that all persons concerned with the project perform their functions as carefully, thoroughly, and honestly as possible.

Willful falsification, distortion, or misrepresentation with respect to any facts related to the project is a violation of Federal law. To prevent any misunderstanding regarding the seriousness of these and similar acts, Form FHWA-1022 shall be posted on each Federal-aid highway project (23 CFR 635) in one or more places where it is readily available to all persons concerned with the project:

18 U.S.C. 1020 reads as follows:

"Whoever, being an officer, agent, or employee of the United States, or of any State or Territory, or whoever, whether a person, association, firm, or corporation, knowingly makes any false statement, false representation, or false report as to the character, quality, quantity, or cost of the material used or to be used, or the quantity or quality of the work performed or to be performed, or the cost thereof in connection with the submission of plans, maps, specifications, contracts, or costs of construction on any highway or related project submitted for approval to the Secretary of Transportation; or

Whoever knowingly makes any false statement, false representation, false report or false claim with respect to the character, quality, quantity, or cost of any work performed or to be performed, or materials furnished or to be furnished, in connection with the construction of any highway or related project approved by the Secretary of Transportation; or

Whoever knowingly makes any false statement or false representation as to material fact in any statement, certificate, or report submitted pursuant to provisions of the Federal-aid Roads Act approved July 1, 1916, (39 Stat. 355), as amended and supplemented;

Shall be fined under this title or imprisoned not more than 5 years or both."

IX. IMPLEMENTATION OF CLEAN AIR ACT AND FEDERAL WATER POLLUTION CONTROL ACT

This provision is applicable to all Federal-aid construction contracts and to all related subcontracts.

By submission of this bid/proposal or the execution of this contract, or subcontract, as appropriate, the bidder, proposer, Federal-aid construction contractor, or subcontractor, as appropriate, will be deemed to have stipulated as follows:

1. That any person who is or will be utilized in the performance of this contract is not prohibited from receiving an award due to a violation of Section 508 of the Clean Water Act or Section 306 of the Clean Air Act.
2. That the contractor agrees to include or cause to be included the requirements of paragraph (1) of this Section X in every subcontract, and further agrees to take such action as the contracting agency may direct as a means of enforcing such requirements.

X. CERTIFICATION REGARDING DEBARMENT, SUSPENSION, INELIGIBILITY AND VOLUNTARY EXCLUSION

This provision is applicable to all Federal-aid construction contracts, design-build contracts, subcontracts, lower-tier subcontracts, purchase orders, lease agreements, consultant contracts or any other covered transaction requiring FHWA approval or that is estimated to cost \$25,000 or more – as defined in 2 CFR Parts 180 and 1200.

1. Instructions for Certification – First Tier Participants:

- a. By signing and submitting this proposal, the prospective first tier participant is providing the certification set out below.
- b. The inability of a person to provide the certification set out below will not necessarily result in denial of participation in this covered transaction. The prospective first tier participant shall submit an explanation of why it cannot provide the certification set out below. The certification or explanation will be considered in connection with the department or agency's determination whether to enter into this transaction. However, failure of the prospective first tier participant to furnish a certification or an explanation shall disqualify such a person from participation in this transaction.
- c. The certification in this clause is a material representation of fact upon which reliance was placed when the contracting agency determined to enter into this transaction. If it is later determined that the prospective participant knowingly rendered an erroneous certification, in addition to other remedies available to the Federal Government, the contracting agency may terminate this transaction for cause of default.
- d. The prospective first tier participant shall provide immediate written notice to the contracting agency to whom this proposal is submitted if any time the prospective first tier participant learns that its certification was erroneous when submitted or has become erroneous by reason of changed circumstances.
- e. The terms "covered transaction," "debarred," "suspended," "ineligible," "participant," "person," "principal," and "voluntarily excluded," as used in this clause, are defined in 2 CFR Parts 180 and 1200. "First Tier Covered Transactions" refers to any covered transaction between a grantee or subgrantee of Federal funds and a participant (such as the prime or general contract). "Lower Tier Covered Transactions" refers to any covered transaction under a First Tier Covered Transaction (such as subcontracts). "First Tier Participant" refers to the participant who has entered into a covered transaction with a grantee or subgrantee of Federal funds (such as the prime or general contractor). "Lower Tier Participant" refers any participant who has entered into a covered transaction with a First Tier Participant or other Lower Tier Participants (such as subcontractors and suppliers).
- f. The prospective first tier participant agrees by submitting this proposal that, should the proposed covered transaction be entered into, it shall not knowingly enter into any lower tier covered transaction with a person who is debarred, suspended, declared ineligible, or voluntarily excluded from participation in this covered transaction, unless authorized by the department or agency entering into this transaction.
- g. The prospective first tier participant further agrees by submitting this proposal that it will include the clause titled "Certification Regarding Debarment, Suspension, Ineligibility and Voluntary Exclusion-Lower Tier Covered Transactions," provided by the department or contracting agency, entering into this covered transaction, without modification, in all lower tier covered transactions and in all solicitations for lower tier covered transactions exceeding the \$25,000 threshold.
- h. A participant in a covered transaction may rely upon a certification of a prospective participant in a lower tier covered transaction that is not debarred, suspended, ineligible, or voluntarily excluded from the covered transaction, unless it knows that the certification is erroneous. A participant is responsible for ensuring that its principals are not suspended, debarred, or otherwise ineligible to participate in covered transactions. To verify the eligibility of its principals, as well as the eligibility of any lower tier prospective participants, each participant may, but is not required to, check the

Excluded Parties List System website (<https://www.epls.gov/>), which is compiled by the General Services Administration.

- i. Nothing contained in the foregoing shall be construed to require the establishment of a system of records in order to render in good faith the certification required by this clause. The knowledge and information of the prospective participant is not required to exceed that which is normally possessed by a prudent person in the ordinary course of business dealings.
- j. Except for transactions authorized under paragraph (f) of these instructions, if a participant in a covered transaction knowingly enters into a lower tier covered transaction with a person who is suspended, debarred, ineligible, or voluntarily excluded from participation in this transaction, in addition to other remedies available to the Federal Government, the department or agency may terminate this transaction for cause or default.

2. Certification Regarding Debarment, Suspension, Ineligibility and Voluntary Exclusion – First Tier Participants:

- a. The prospective first tier participant certifies to the best of its knowledge and belief, that it and its principals:
 - (1) Are not presently debarred, suspended, proposed for debarment, declared ineligible, or voluntarily excluded from participating in covered transactions by any Federal department or agency;
 - (2) Have not within a three-year period preceding this proposal been convicted of or had a civil judgment rendered against them for commission of fraud or a criminal offense in connection with obtaining, attempting to obtain, or performing a public (Federal, State or local) transaction or contract under a public transaction; violation of Federal or State antitrust statutes or commission of embezzlement, theft, forgery, bribery, falsification or destruction of records, making false statements, or receiving stolen property;
 - (3) Are not presently indicted for or otherwise criminally or civilly charged by a governmental entity (Federal, State or local) with commission of any of the offenses enumerated in paragraph (a)(2) of this certification; and
 - (4) Have not within a three-year period preceding this application/proposal had one or more public transactions (Federal, State or local) terminated for cause or default.
- b. Where the prospective participant is unable to certify to any of the statements in this certification, such prospective participant shall attach an explanation to this proposal.

3. Instructions for Certification - Lower Tier Participants:

(Applicable to all subcontracts, purchase orders and other lower tier transactions requiring prior FHWA approval or estimated to cost \$25,000 or more - 2 CFR Parts 180 and 1200)

- a. By signing and submitting this proposal, the prospective lower tier is providing the certification set out below.
- b. The certification in this clause is a material representation of fact upon which reliance was placed when this transaction was entered into. If it is later determined that the prospective lower tier

participant knowingly rendered an erroneous certification, in addition to other remedies available to the Federal Government, the department, or agency with which this transaction originated may pursue available remedies, including suspension and/or debarment.

- c. The prospective lower tier participant shall provide immediate written notice to the person to which this proposal is submitted if at any time the prospective lower tier participant learns that its certification was erroneous by reason of changed circumstances.
- d. The terms "covered transaction," "debarred," "suspended," "ineligible," "participant," "person," "principal," and "voluntarily excluded," as used in this clause, are defined in 2 CFR Parts 180 and 1200. You may contact the person to which this proposal is submitted for assistance in obtaining a copy of those regulations. "First Tier Covered Transactions" refers to any covered transaction between a grantee or subgrantee of Federal funds and a participant (such as the prime or general contract). "Lower Tier Covered Transactions" refers to any covered transaction under a First Tier Covered Transaction (such as subcontracts). "First Tier Participant" refers to the participant who has entered into a covered transaction with a grantee or subgrantee of Federal funds (such as the prime or general contractor). "Lower Tier Participant" refers any participant who has entered into a covered transaction with a First Tier Participant or other Lower Tier Participants (such as subcontractors and suppliers).
- e. The prospective lower tier participant agrees by submitting this proposal that, should the proposed covered transaction be entered into, it shall not knowingly enter into any lower tier covered transaction with a person who is debarred, suspended, declared ineligible, or voluntarily excluded from participation in this covered transaction, unless authorized by the department or agency with which this transaction originated.
- f. The prospective lower tier participant further agrees by submitting this proposal that it will include this clause titled "Certification Regarding Debarment, Suspension, Ineligibility and Voluntary Exclusion-Lower Tier Covered Transaction," without modification, in all lower tier covered transactions and in all solicitations for lower tier covered transactions exceeding the \$25,000 threshold.
- g. A participant in a covered transaction may rely upon a certification of a prospective participant in a lower tier covered transaction that is not debarred, suspended, ineligible, or voluntarily excluded from the covered transaction, unless it knows that the certification is erroneous. A participant is responsible for ensuring that its principals are not suspended, debarred, or otherwise ineligible to participate in covered transactions. To verify the eligibility of its principals, as well as the eligibility of any lower tier prospective participants, each participant may, but is not required to, check the Excluded Parties List System website (<https://www.epls.gov/>), which is compiled by the General Services Administration.
- h. Nothing contained in the foregoing shall be construed to require establishment of a system of records in order to render in good faith the certification required by this clause. The knowledge and information of participant is not required to exceed that which is normally possessed by a prudent person in the ordinary course of business dealings.
- i. Except for transactions authorized under paragraph e of these instructions, if a participant in a covered transaction knowingly enters into a lower tier covered transaction with a person who is suspended, debarred, ineligible, or voluntarily excluded from participation in this transaction, in addition to other remedies available to the Federal Government, the department or agency with

which this transaction originated may pursue available remedies, including suspension and/or debarment.

4. Certification Regarding Debarment, Suspension, Ineligibility and Voluntary Exclusion--Lower Tier Participants:

- a. The prospective lower tier participant certifies, by submission of this proposal, that neither it nor its principals is presently debarred, suspended, proposed for debarment, declared ineligible, or voluntarily excluded from participating in covered transactions by any Federal department or agency.
- b. Where the prospective lower tier participant is unable to certify to any of the statements in this certification, such prospective participant shall attach an explanation to this proposal.

XI. CERTIFICATION REGARDING USE OF CONTRACT FUNDS FOR LOBBYING

This provision is applicable to all Federal-aid construction contracts and to all related subcontracts which exceed \$100,000 (49 CFR 20).

1. The prospective participant certifies, by signing and submitting this bid or proposal, to the best of his or her knowledge and belief, that:
 - a. No Federal appropriated funds have been paid or will be paid, by or on behalf of the undersigned, to any person for influencing or attempting to influence an officer or employee of any Federal agency, a Member of Congress, an officer or employee of Congress, or an employee of a Member of Congress in connection with the awarding of any Federal contract, the making of any Federal grant, the making of any Federal loan, the entering into of any cooperative agreement, and the extension, continuation, renewal, amendment, or modification of any Federal contract, grant, loan, or cooperative agreement.
 - b. If any funds other than Federal appropriated funds have been paid or will be paid to any person for influencing or attempting to influence an officer or employee of any Federal agency, a Member of Congress, an officer or employee of Congress, or an employee of a Member of Congress in connection with this Federal contract, grant, loan, or cooperative agreement, the undersigned shall complete and submit Standard Form-LLL, "Disclosure Form to Report Lobbying," in accordance with its instructions.
2. This certification is a material representation of fact upon which reliance was placed when this transaction was made or entered into. Submission of this certification is a prerequisite for making or entering into this transaction imposed by 31 U.S.C. 1352. Any person who fails to file the required certification shall be subject to a civil penalty of not less than \$10,000 and not more than \$100,000 for each such failure.
3. The prospective participant also agrees by submitting its bid or proposal that the participant shall require that the language of this certification be included in all lower tier subcontracts, which exceed \$100,000 and that all such recipients shall certify and disclose accordingly.

XII. USE OF UNITED STATES-FLAG VESSELS (CARGO PREFERENCE ACT)

The CONTRACTOR agrees-

1. To utilize privately owned United States-flag commercial vessels to ship at least 50 percent of the gross tonnage (computed separately for dry bulk carries, dry cargo liners, and tankers) involved, whenever shipping any equipment, material, or commodities pursuant to this contract, to the extent such vessels are available at fair and reasonable rates for United States-flag commercial vessels.
2. To Furnish within 20 days following the date of loading for shipments originating within the United State or within 30 working days following the date of loading for shipments originating outside the United States, a legible copy of a rated "on-board" commercial ocean bill-of-lading in English for each shipment of cargo described in paragraph (1) of this section to both the Contracting Officer (through the prime contractor in the case of subcontractor bills-of-lading) and to the Division of National Cargo, Office of Market Development, Maritime Administration, Washington, DC 20590.
3. To insert the substance of the provisions of this clause in all subcontracts issued pursuant to this contract.

IN WITNESS WHEREOF the parties hereto for themselves, their heirs, executors, administrators, successors, and assigns do hereby agree to the full performance of the covenants herein contained and have caused this Contract Agreement to be executed in duplicate by setting hereunto their names, titles, hands, and seals this ____ day of _____ 2016.

Contractor:

 <Type Business Name Here>

Name: _____

Title: _____

Contractor's License No. _____

Agency Business License No. _____

Federal Tax Identification No. _____

[Contractor's signature(s) must be notarized. Attach Notary Acknowledgment to this document.]

o o o

Agency:

 City Manager of the City of Lafayette

Attested:

 City Clerk of the City of Lafayette

Date: _____

PAYMENT BOND

(TO BE EXECUTED WITHIN TEN [10] CALENDAR DAYS OF CONTRACT AWARD)

WHEREAS, the City of Lafayette (Owner) has awarded to _____, as Contractor, a contract for the work described as follows: for Construction of **Taylor Blvd/Pleasant Hill Rd Safety Project, Project No. 014-9708**, including, but not limited to: mobilization; traffic control and construction signage; potholing utilities; removal and disposal of traffic striping, markers and markings, asphalt concrete berm, subgrade, native materials; minor grading; construction of high-friction pavement surface treatment, concrete barrier (K-rail), metal beam guard rail, asphalt concrete berm; installation of traffic signs, stripes, markers, and markings; and all other work as shown on the Plans and as described in the Specifications to provide a complete project.

AND WHEREAS, said Contractor is required to furnish a bond in connection with said contract, to secure the payment of claims of laborers, mechanics, materials persons, and other persons as provided by law;

NOW, THEREFORE, we, the undersigned Contractor and surety, are held firmly bound unto the Owner in the sum of _____ Dollars (\$ _____), for which payment well and truly to be made we bind ourselves, our heirs, executors and administrators, successors and assigns, jointly and severally, firmly by these presents.

THE CONDITION OF THIS OBLIGATION IS SUCH:

That if said Contractor, its heirs, executors, administrators, successors, or assigns, or subcontractors, shall fail to pay any of the persons named in Civil Code Section 3282, or amounts due under the Unemployment Insurance Code with respect to work or labor performed by any such claimant, or any amounts required to be deducted, withheld, and paid over to the Employment Development Department from the wages of employees of the Contractor and its subcontractors pursuant to Section 13020 of the Unemployment Insurance Code, with respect to such work and labor, that the surety or sureties herein will pay for the same in any amount not exceeding the sum specified in this bond, otherwise the above obligation shall be void. In case suit is brought upon this bond, the said surety will pay a reasonable attorney's fee to the Owner in an amount to be fixed by the court.

This bond shall insure to the benefit of any of the persons named in Civil Code Section 3181 as to give a right of action to such persons or their assigns in any suit brought upon this bond.

IN WITNESS WHEREOF, we have hereunto set our hands and seals on this ____ day of _____, 2016.

CONTRACTOR: _____ SURETY _____

Print Name: _____ NAME _____

Title: _____ ADDRESS _____

TELEPHONE _____

PERFORMANCE BOND

(TO BE EXECUTED WITHIN TEN [10] CALENDAR DAYS OF CONTRACT AWARD)

KNOW ALL PERSONS BY THESE PRESENTS:

THAT WHEREAS, the City of Lafayette (Owner) has awarded to _____, as Contractor, a contract for the work described as follows: for Construction of **Taylor Blvd/Pleasant Hill Rd Safety Project, Project No. 014-9708**, including, but not limited to: mobilization; traffic control and construction signage; potholing utilities; removal and disposal of traffic striping, markers and markings, asphalt concrete berm, subgrade, native materials; minor grading; construction of high-friction pavement surface treatment, concrete barrier (K-rail), metal beam guard rail, asphalt concrete berm; installation of traffic signs, stripes, markers, and markings; and all other work as shown on the Plans and as described in the Specifications to provide a complete project.

AS WHEREAS, the Contractor is required to furnish a bond in connection with said contract guaranteeing the faithful performance thereof;

NOW, THEREFORE, we, the undersigned Contractor and surety, are held firmly bound unto the Owner in the sum of _____ Dollars (\$_____), to be paid to the Owner, its successors and assigns, for which payment well and truly to be made we bind ourselves, our heirs, executors and administrators, successors and assigns, jointly and severally, firmly by these presents.

THE CONDITION OF THIS OBLIGATION IS SUCH:

That if said Contractor, its heirs, executors, administrators, successors, or assigns, shall in all things stand to and abide by and well and truly keep and perform the covenants, conditions, and agreements in the foregoing contract and any alteration thereof made as therein provided on its or their part to be kept and performed at the time and in the manner therein specified and in all respects according to their true intent and meaning, and shall indemnify and save harmless the Owner, its officers, and agents, as therein stipulated, then this obligation shall become and be null and void; otherwise it shall be and remain in full force and effect. In case suit is brought upon this bond, the said surety will pay a reasonable attorney's fee to the Owner in an amount to be fixed by the court. Surety, for value received, hereby stipulates and agrees that no amendment, change, extension of time, alteration, or addition to said contract, and of any feature or item or items of performance required therein or thereunder, shall in any manner affect its obligations on or under this bond; and said surety does hereby waive notice of any such amendment, change, extension of time, alteration, or addition to said contract, and of any feature or item or items of performance required therein or thereunder, shall in any manner affect its obligations on or under this bond; and said surety does hereby waive notice of any such amendment, change extension of time, alteration, or addition to said contract, and of any feature or item or items of performance required therein or thereunder.

IN WITNESS WHEREOF, we have hereunto set our hands and seals on this ____ day of _____, 2016.

CONTRACTOR: _____ SURETY _____

Print Name: _____ NAME _____

Title: _____ ADDRESS _____

TELEPHONE _____

**FEDERAL MINIMUM WAGE RATES
(TO BE ATTACHED TO SIGNED CONTRACT)**

**CITY OF LAFAYETTE
SPECIAL PROVISIONS
GENERAL**

The work to be done under this contract, except as modified or supplemented herein, shall conform to the following:

- The City of Lafayette General Provisions of the Standard Specifications dated **March 2013**, herein referred to as the “General Provisions of the Standard Specifications,” or “General Provisions.”
- The City of Lafayette Technical Provisions of the Standard Specifications dated **March 2013**, herein referred to as the “Technical Provisions of the Standard Specifications,” or “Technical Provisions.”

Where specifically referred to, the work shall also conform to the following:

- The State of California Department of Transportation (Caltrans) Standard Specifications, dated 2015, herein referred to as the “State Specifications” or “State Standard Specifications”.
- The State of California Department of Transportation (Caltrans) Standard Plans, dated 2015, herein referred to as the “State Standard Plans”.
- The Contra Costa County Public Works Department Standard Plans, most current edition, herein referred to as the “County Standard Plans”.

These Special Provisions are additions, modifications, or clarifications to the City of Lafayette Standard Specifications. These Special Provisions supersede all sections of the Standard Specifications where there is a conflict.

Refer to Section 5-4, “Precedence of Contract Documents”, of the General Provisions of the Standard Specifications for the order of precedence of contract documents.

SPECIAL PROVISIONS SECTION SP-1
TERMS, DEFINITIONS AND ABBREVIATIONS
(NO BID ITEM)

The provisions of Section 1, “Terms, Definitions and Abbreviations”, of the General Provisions of the Standard Specifications, shall apply in their entirety.

SPECIAL PROVISIONS SECTION SP-2

BID PROPOSAL REQUIREMENTS

(NO BID ITEM)

SP2-01 GENERAL

The provisions of Section 2, "Bid Proposal Requirements", of the General Provisions of the Standard Specifications shall apply in their entirety.

In conformance with Public Contract Code Section 7106, a Noncollusion Affidavit is included in the Bid Proposal. Signing the Bid Proposal shall also constitute signature of the Noncollusion Affidavit.

Contractor or subcontractor shall not discriminate on the basis of race, color, national origin, or sex in the performance of this Contract. Contractor shall carry out applicable requirements of Title 49 CFR (Code of Federal Regulations) part 26 in the award and administration of US DOT assisted contracts. Failure by Contractor to carry out these requirements is a material breach of this Contract, which may result in its termination or such other remedy as City deems appropriate. Each subcontract signed by the Bidder or Contractor must include this assurance.

SP2-02 FEDERAL LOBBYING RESTRICTIONS

A certification for Federal-aid contracts regarding payment of funds to lobby Congress or a Federal agency is included in the Proposal. Standard Form - LLL, "Disclosure of Lobbying Activities," with instructions for completion of the Standard Form is also included in the Proposal. Signing the Proposal shall constitute signature of the Certification.

SP2-03 DISADVANTAGED BUSINESS ENTERPRISE (DBE)

This project is subject to Title 49 CFR 26.13(b):

The contractor, subrecipient or subcontractor shall not discriminate on the basis of race, color, national origin, or sex in the performance of this contract. The contractor shall carry out applicable requirements of 49 CFR part 26 in the award and administration of DOT-assisted contracts. Failure by the contractor to carry out these requirements is a material breach of this contract, which may result in the termination of this contract or such other remedy as the recipient deems appropriate.

Contractor shall take necessary and reasonable steps to ensure that DBEs have opportunity to participate in the contract (49 CFR 26). To ensure equal participation of DBEs provided in 49 CFR 26.5, City has included a goal for DBEs. Contractor shall make work available to DBEs and select work parts consistent with available DBE subcontractors and suppliers. Contractor shall meet the DBE goal shown elsewhere in these Special Provisions or demonstrate that he has made adequate good-faith efforts to meet this goal.

It is Contractor's responsibility to verify that the DBE firm is certified as DBE on the date of bid opening. For a list of DBEs certified by the California Unified Certification Program, Contractor may review: http://www.dot.ca.gov/hq/bep/find_certified.htm.

All DBE participation will count toward the California Department of Transportation's federally mandated statewide overall DBE goal. Credit for materials or supplies purchased by Contractor from DBEs counts towards the goal in the following manner:

- 100 percent credit if the materials or supplies are obtained from a DBE manufacturer.
- 60 percent credit if the materials or supplies are obtained from a DBE regular dealer.
- Only fees, commissions, and charges for assistance in the procurement and delivery of materials or supplies count if obtained from a DBE that is neither a manufacturer nor regular dealer. 49 CFR 26.55 defines "manufacturer" and "regular dealer."

Contractor shall receive credit towards the goal if he employs a DBE trucking company that performs a commercially useful function as defined in 49 CFR 26.55(d)(1) through (4) and (6).

A. DBE Commitment Submittal

Contractor shall submit Exhibit 15-G *Local Agency Bidder DBE Commitment (Construction Contracts)* form, included in the Bid Proposal. If the form is not intended to be submitted with the Bid, it shall be removed from the Bid Proposal before submitting Bid.

If the DBE Commitment form is not submitted with the Bid, the apparent low bidder, the 2nd low bidder, and the 3rd low bidder must complete and submit the DBE Commitment form to City, to be received no later than 4:00 p.m. on the 4th business day after bid opening.

Other bidders do not need to submit the DBE Commitment form unless the City requests it. If requested, a bidder shall submit the completed form within 4 business days of the request.

Contractor shall submit written confirmation from each DBE firm stating that it is participating in the contract, and include said confirmation with the DBE Commitment form. A copy of a DBE firm's quote may serve as written confirmation that the DBE is participating in the contract. DBE firms participating as a joint venture partner are encouraged to submit a copy of the joint venture agreement.

Contractor's failure to submit the DBE Commitment form within the specified time shall constitute sufficient ground for City to find his bid nonresponsive.

B. Good Faith Efforts Submittal

If Contractor has not met the DBE goal, he shall complete and submit the DBE Information - Good Faith Efforts form, Exhibit 15-H, with the Bid showing that he has made adequate good-faith efforts to meet the goal. Only good-faith efforts directed towards obtaining participation by DBE firms will be considered. If good-faith efforts documentation is not submitted with the Bid, it must be received by the City no later than 4:00 p.m. on the 4th business day after bid opening.

Even if Contractor's DBE Commitment form shows that he has met the DBE goal, or if Contractor has been required to submit the DBE Commitment form for any reason, he must also submit

good-faith efforts documentation within the specified time to protect his eligibility for award of the contract in the event that City finds that the DBE goal has not been met.

Good-faith efforts documentation must include the following information and supporting documents, as necessary:

1. Items of work that have been made available to DBE firms- Contractor shall identify those items of work that might otherwise be performed with his own forces and those items that have been broken down into economically feasible units to facilitate DBE participation. For each item listed, show the dollar value and percentage of the total contract. It is Contractor's responsibility to demonstrate that sufficient work to meet the goal has been made available to DBE firms.
2. Names of certified DBE firms and dates on which they are solicited to bid on the project- Contractor shall include the items of work offered, and describe the methods used for following up initial solicitations to determine with certainty if the DBE firms are interested, and the dates of said follow-up. Contractor shall attach supporting documents such as copies of letters, memos, facsimiles sent, telephone logs, telephone billing statements, and other evidence of solicitation. Contractor shall solicit certified DBE firms through all reasonable and available means and provide sufficient time to allow DBE firms to respond.
3. Name of selected firm and its status as a DBE for each item of work made available- Contractor shall include name, address, and telephone number of each DBE firm that has provided a quote and the quoted price. If the firm selected for the item is not a DBE, Contractor shall provide the reasons for the selection.
4. Name and date of each publication in which Contractor has requested DBE participation for the project, including copies of the published advertisements.
5. Names of agencies and dates on which they were contacted to provide assistance in contacting, recruiting, and using DBE firms- If the agencies were contacted in writing, Contractor shall provide copies of supporting documents.
6. List of efforts made to provide interested DBE firms with adequate information about the plans, specifications, and requirements of the contract to assist them in responding to a solicitation- If Contractor has provided information, he shall identify the name of the DBE firm assisted, the nature of the information provided, and date of contact, and copies of supporting documents, as appropriate.
7. List of efforts made to assist interested DBE firms in obtaining bonding, lines of credit, insurance, necessary equipment, supplies, and materials, excluding supplies and equipment that the DBE subcontractor purchases or leases from the prime contractor or its affiliate- If Contractor has provided such assistance, he shall identify the name of the DBE assisted, nature of the assistance offered, and date assistance provided, and copies of supporting documents, as appropriate.
8. Any additional data to support demonstration of good-faith efforts.

City may comparatively consider DBE commitments of the 2nd and 3rd bidders when determining whether the low bidder has made good-faith efforts to meet the DBE goal.

C. Exhibit 15-G-Local Agency Bidder DBE Information

Contractor shall complete and sign Exhibit 15-G *Local Agency Bidder DBE Commitment* included in the contract documents regardless of whether DBE participation is reported.

Contractor shall provide written confirmation from each DBE that the DBE is participating the Contract. A copy of a DBE's quote serves as written confirmation. If a DBE is participating as a joint venture partner, the City encourages you to submit a copy of the joint venture agreement.

D. Subcontractor and Disadvantaged Business Enterprise Records

Contractor shall use each DBE subcontractor as listed on Exhibit 12-B *Bidder's List of Subcontractors (DBE and Non-DBE)* and Exhibit 15-G *Local Agency Bidder DBE Commitment* form, unless he receives authorization for a substitution.

Contractor shall:

1. Notify the Engineer of any changes to its anticipated DBE participation;
2. Provide this notification before starting the affected work;
3. Maintain records including:
 - Name and business address of each 1st-tier subcontractor
 - Name and business address of each DBE subcontractor, DBE vendor, and DBE trucking company, regardless of tier;
 - Date of payment and total amount paid to each business.

If Contractor is a DBE Contractor, he shall include the date of work performed by his own forces and the corresponding value of the work.

Before the 15th of each month, Contractor shall submit a Monthly DBE Trucking Verification form.

DBE contractors shall log the dates of work performed and the corresponding value of the work.

If a DBE firm is decertified before completing its work under Contract, it must notify Contractor in writing of the decertification date. If a business becomes a certified DBE firm before completing its work under Contract, it must notify Contractor in writing of the certification date. Contractor shall submit the notifications to City. On work completion, Contractor shall complete a Disadvantaged Business Enterprises (DBE) Certification Status Change form, Exhibit 17-O, and submit to City within 30 days of Contract Acceptance.

Upon work completion, Contractor shall complete Exhibit 17-F, *Final Report – Utilization of Disadvantaged Business Enterprises (DBE), First-Tier Subcontractors*, and submit to City within 90 days of Contract Acceptance. City shall withhold \$10,000 as part of retention of contract payment until the form is submitted.

E. Performance of Disadvantaged Business Enterprises

DBE firms must perform work or supply materials as listed in the Exhibit 15-G, *Local Agency Bidder DBE Commitment (Construction Contracts)* form, included in the Bid.

Contractor shall not terminate or substitute a listed DBE for convenience and perform the work with other forces or obtain materials from other sources without authorization from City.

City may authorize a request to use other forces or sources of materials, if Contractor shows any of the following justifications:

1. Listed DBE firm fails or refuses to execute a written contract based on plans and specifications for the project.
2. Contractor has stipulated that a bond is a condition of executing the subcontract, and the listed DBE firm fails to meet your bond requirements.
3. Work requires a contractor's license, and listed DBE firm does not have a valid license under Contractors License Law.
4. Listed DBE firm fails or refuses to perform the work or furnish the listed materials.
5. Listed DBE firm's work is unsatisfactory and not in compliance with the contract.
6. Listed DBE firm is ineligible to work on the project because of suspension or debarment.
7. Listed DBE firm becomes bankrupt or insolvent.
8. Listed DBE firm voluntarily withdraws from the Contract by written notice.
9. Listed DBE firm is ineligible to receive credit for the type of work required.
10. Listed DBE owner dies or becomes disabled, resulting in the inability of the firm to perform the work on the Contract.
11. Other documented good cause as determined by City.

Contractor shall notify the original DBE firm of intent to use other forces or material sources and provide the reasons for intent. Contractor shall allow the DBE firm five (5) days to respond to the notice and advise any reasons why the use of other forces or sources of materials should not occur. Contractor's request to City to use other forces or material sources must include:

1. One or more of the reasons listed above
2. Notices from Contractor to DBE firm regarding the request
3. Responses from the DBE to Contractor regarding the request

If a listed DBE firm is terminated or substituted, Contractor must make good-faith efforts to find a substitution DBE firm. The substitute DBE firm must perform at least the same amount of work as the original one under the contract to the extent needed to meet the DBE goal.

The substitute DBE firm must be certified as such at the time of request for substitution.

Unless City has authorized either- (1) a request to use other forces or sources of materials, or (2) a good-faith effort for a substitution of a terminated DBE firm; City shall not pay for any work listed on the Exhibit 15-G *Local Agency Bidder DBE Commitment (Construction Contracts)* form, unless said work is performed or supplied by the listed DBE firm or an authorized substitute.

SP2-04 FEMALE AND MINORITY GOALS

To comply with Section II, "Nondiscrimination," of "Required Contract Provisions Federal-Aid Construction Contracts," the following are goals for female and minority utilization goals for Federal-aid construction contracts and subcontracts that exceed \$10,000:

The nationwide goal for female utilization is 6.9 percent.

The goals for minority utilization [45 Fed Reg 65984 (10/3/1980)] are as follows:

MINORITY UTILIZATION GOALS

Economic Area		Goal (Percent)
176	San Francisco-Oakland-San Jose, CA: SMSA Counties: 7120 Salinas-Seaside-Monterey, CA CA Monterey	28.9
	7360 San Francisco-Oakland CA Alameda; CA Contra Costa; CA Marin; CA San Francisco; CA San Mateo	25.6
	7400 San Jose, CA CA Santa Clara, CA	19.6
	7485 Santa Cruz, CA CA Santa Cruz	14.9
	7500 Santa Rosa CA Sonoma	9.1
	8720 Vallejo-Fairfield-Napa, CA CA Napa; CA Solano	17.1
	Non-SMSA Counties: CA Lake; CA Mendocino; CA San Benito	23.2

For each July during which work is performed under the contract, Contractor and each non material-supplier subcontractor with a subcontract of \$10,000 or more must complete Form FHWA PR-1391 (Appendix C to 23 CFR 230) and submit the forms by August 15.

SP2-04 BID RIGGING

The U.S. Department of Transportation (DOT) provides a toll-free hotline, (800) 424-9071, to report bid rigging activities. The hotline number is. The service is available 24 hours a day, 7 days a week, and is confidential and anonymous. The hotline is part of the DOT's effort to identify and investigate highway construction contract fraud and abuse and is operated under the direction of the DOT Inspector General. Anyone may Use the hotline to report bid rigging, bidder collusion, and other fraudulent activities.

SPECIAL PROVISIONS SECTION SP-3

AWARD AND EXECUTION OF CONTRACT

(NO BID ITEM)

The provisions of Section 3, "Award and Execution of Contract", of the General Provisions of the Standard Specifications shall apply in their entirety and as supplemented herein.

In determining whether a bidder is "responsible" for purposes of the contract award, the City may consider information regarding the bidder's performance on projects for other public agencies as well as other information relevant to "responsibility" as defined in Public Contract Code Section 1103.

Full compensation for furnishing "Performance, Labor, and Materials Bonds" shall be considered as included in the lump sum price paid for "Mobilization" and no additional compensation shall be allowed therefor, even if the final Contract Price is increased up to 25% of the original base bid price.

SPECIAL PROVISIONS SECTION SP-4

PLANS AND SPECIFICATIONS (GENERAL)

(NO BID ITEM)

The provisions of Section 4, "Plans and Specifications (General)", of the General Provisions of the Standard Specifications shall apply in their entirety and as supplemented herein.

SP4-01 SCOPE OF WORK

The work to be performed under this contract including, but not limited to: mobilization; traffic control and construction signage; potholing utilities; removal and disposal of traffic striping, markers and markings, asphalt concrete berm, subgrade, native materials; minor grading; construction of high-friction pavement surface treatment, concrete barrier (K-rail), metal beam guard rail, asphalt concrete berm; installation of traffic signs, stripes, markers, and markings; and all other work as shown on the Plans and as described in the Specifications to provide a complete project.

SPECIAL PROVISIONS SECTION SP-5

CONTROL OF WORK AND MATERIALS

(NO BID ITEM)

The provisions of Section 5, "Control of Work and Materials", of the General Provisions of the Standard Specifications shall apply in their entirety and as supplemented herein.

SP5-01 SUBMITTALS

At minimum, the Contractor shall provide the following submittals to the Engineer:

- 1) Water Pollution Control Plan
- 2) Waste Management Plan
- 3) Traffic Control Plan and certification of "Qualified Personnel"
- 4) Asphalt concrete mix design for berm

- 5) Portland cement concrete mix designs for various items
- 6) Pavement markers
- 7) Thermoplastic striping material
- 8) Buy America Certification for Steel
- 9) Additional submittals as noted in each section of these Special Provisions

SP5-02 ORDER OF WORK

Unless otherwise directed by the Engineer, the following major items of work shall be performed in the following order.

- 1) Notify Underground Service Alert (USA) to have utilities marked.
- 2) Install construction area signs, and project identification signs.
- 3) Install water pollution control measures.
- 4) Install tree protection as required.
- 5) Submit waste management plan prior to commencing any demolition work.
- 6) Perform utility potholing work to confirm depths of existing utility lines. No additional excavation work will be permitted until Contractor's Utility Pothole Log (Appendix B) is submitted to the Engineer.
- 7) Install concrete barriers, guard rails
- 8) Install high friction surface treatment
- 9) Install traffic signs, stripes, markers and markings.
- 10) Complete final punch list and clean up.
- 11) Remove tree protection, construction area signs and project identification signs.
- 12) Submit completed waste assessment summary report form.

SP5-03 REUSE AND RECYCLING REQUIREMENTS

Assessment and report forms referenced in Section 5-19 of the General Provisions are found in **Appendix A** of these Special Provisions.

SP5-04 PAYMENT

No separate payment will be made for conforming to the provisions of this section. Full compensation for conforming to all the provisions of this section shall be considered as included in the prices paid for various contract items of work and no additional compensation shall be allowed therefor.

SPECIAL PROVISIONS SECTION SP-6

LEGAL RELATIONS AND RESPONSIBILITIES

(NO BID ITEM)

The provisions of Section 6, "Legal Relations and Responsibilities", of the General Provisions of the Standard Specifications shall apply in their entirety and as supplemented herein, and in other related sections of these Special Provisions.

SP6-01 CONTRACTOR'S LICENSING LAWS

The Contractor must be properly licensed as a contractor from contract award through Contract acceptance (Public Contract Code Section 10164).

SP6-02 PUBLIC NOTIFICATIONS

Notification requirements in Section 6-12.3, and 6-13 of the Standard Specifications General Provisions shall apply. In addition, at least two changeable message signs shall be provided at least one week in advance of start of work to notify the public of impending road work and lane closures. Contractor shall submit sign messages for approval by the Engineer prior to installation of signs.

SP6-03 PAYMENT

No separate payment will be made for conforming to the provisions of this section. Full compensation for conforming to all the provisions of this section, including rain protection, shall be considered as included in the prices paid for various contract items of work and no additional compensation shall be allowed therefor.

SPECIAL PROVISIONS SECTION SP-7

EXISTING UTILITIES

(NO BID ITEM)

The provisions of Section 7, "Existing Utilities", of the General Provisions of the Standard Specifications shall apply in their entirety and as supplemented herein.

Unless a separate contract item is specified in the Bid Schedule, no separate payment shall be made for conforming to the provisions of this section. Full compensation for conforming to all the provisions of this section shall be considered as included in the prices paid for various contract items of work and no additional compensation shall be allowed therefor.

SPECIAL PROVISIONS SECTION SP-8

PROGRESS OF WORK

(NO BID ITEM)

The provisions of Section 8, "Progress of Work", of the General Provisions of the Standard Specifications shall apply in their entirety and as supplemented herein.

SP8-01 PRE-CONSTRUCTION MEETING

A pre-construction meeting for this project will be held at the City Offices. The Contractor shall submit all required bonds, insurance, and signed contracts prior to this meeting. The Notice to Proceed will be issued to the Contractor at the pre-construction meeting.

At the pre-construction meeting, representatives of the Contractor, Subcontractors, and the Engineer will discuss in detail certain procedural aspects of the Work, including, but not limited to:

- Administrative procedures for transmittals, approvals, change orders, and similar items;
- Review of the method of application for payment, progress payments, retention; and final payment;
- Review of the Contractor’s construction progress schedule;
- Clarifications of any questions regarding the contract Plans and Special Provisions;
- Review of traffic control procedures;
- At the preconstruction meeting the Contractor shall provide a traffic control plan.

SP8-02 PROGRESS SCHEDULE

The Contractor shall submit the construction progress schedule to the Engineer at the pre-construction meeting. Contractor shall also submit an updated schedule each week during construction on or before Friday morning or as requested by the Engineer as the work progresses as stated in Section 8-2, “Progress Schedule”, of the General Provisions of the Standard Specifications.

Attention is directed to Section SP5-02, “Order of Work”, of these Special Provisions. Each schedule shall specifically note the timeframe and work to be performed by all subcontractors. Subcontractors shall receive all updated schedules so they can plan an appropriate work force to meet the prime Contractor’s timeframe.

SP8-03 WORKING HOURS AND SITE ACCESS

Without prior written approval by the Engineer, and except for emergency work, work or activity of any kind shall be limited to the hours from 8 a.m. to 5 p.m. Monday through Friday. The Contractor’s attention is directed to Section SP14-04, “Lane Closure Hours”, of these Special Provisions.

The Contractor shall provide for continuous unobstructed path of ingress and egress to all public and private properties within and adjacent to the area of work. Access shall be ADA compliant.

SP8-04 TIME OF COMPLETION AND LIQUIDATED DAMAGES

The Contractor shall complete the entire work in this contract within **fifteen (15)** working days from the original start date including completion of all “Punch List” work. The Contractor’s attention is directed to Section 8-10, “Liquidated Damages”, of the General Provisions of the Standard Specifications. Liquidated damages shall be assessed per said Section 8-10.

SP8-05 DIFFERING SITE CONDITIONS

1) Contractor's Notification

Contractor shall promptly notify the Engineer if he finds either of the following conditions:

- a. Physical conditions differing materially from either the Contract Documents or his job site examination prior to submitting a bid.
- b. Physical conditions of an unusual nature, differing materially from those ordinarily encountered and generally recognized as inherent in the work provided for in the Contract.

Include details explaining the information you relied on and the material differences you discovered.

If you fail to promptly notify the Engineer, you waive the differing site condition claim for the period between your discovery of the differing site condition and your notification to the Engineer.

If you disturb the site after discovery and before the Engineer's investigation, you waive the differing site condition claim.

2) Engineer's Investigation and Decision

Upon receiving notification, Engineer will investigate job site conditions and notify Contractor whether to resume affected work and decide whether the condition differs materially and is cause for an adjustment of contract time, payment, or both.

SP8-06 PAYMENT

No separate payment will be made for conforming to the provisions of this section. Full compensation for conforming to all the provisions of this section shall be considered as included in the prices paid for various contract items of work and no additional compensation shall be allowed therefor.

SPECIAL PROVISIONS SECTION SP-9

MEASUREMENT AND PAYMENT

(NO BID ITEM)

The provisions of Section 9, "Measurement and Payment", of the General Provisions of the Standard Specifications shall apply in their entirety except as noted in Section SP8-05 Contract Changes, Change Orders and Extra Work" and as supplemented herein.

No separate payment will be made for conforming to the provisions of this section. Full compensation for conforming to all the provisions of this section shall be considered as included in the prices paid for various contract items of work and no additional compensation shall be allowed therefor.

SPECIAL PROVISIONS SECTION SP-10

NOT USED

SPECIAL PROVISIONS SECTION SP-11

MISCELLANEOUS
(NO BID ITEMS)

SP11-01 LABOR NONDISCRIMINATION

Attention is directed to the following Notice that is required by Chapter 5 of Division 4 of Title 2, California Code of Regulations.

NOTICE OF REQUIREMENT FOR NONDISCRIMINATION PROGRAM
(GOV. CODE, SECTION 12990)

Contractor's attention is called to the "Nondiscrimination Clause", set forth in Section 7-1.021(2), "Nondiscrimination," of the State Specifications, which is applicable to all nonexempt state contracts and subcontracts, and to the "Standard California Nondiscrimination Construction Contract Specifications" set forth therein. The Specifications are applicable to all state construction contracts and subcontracts of \$5,000 or more.

SP11-02 STATE PREVAILING WAGE AND FEDERAL MINIMUM WAGE RATES.

Attention is directed to Section 6-3.3, "Prevailing Wage," of the General Provisions of the Standard Specifications.

Attention is directed to the Federal minimum wage rate requirements in the Contract Agreement. If there is a difference between the minimum wage rates predetermined by the Secretary of Labor and the General Prevailing Wage Rates determined by the Director of the California Department of Industrial Relations for similar classifications of labor, the Contractor and subcontractors shall pay not less than the higher wage rate. City will not allow lower State wage rates specifically included in the Federal minimum wage determinations. This includes "helper" (or classifications based on hours of experience) or any other classifications not appearing in the Federal wage determinations. Where Federal wage determinations do not contain the State wage rate determination otherwise available for use by the Contractor and subcontractors, the Contractor and subcontractors shall pay not less than the Federal minimum wage rate which most closely approximates the duties of the employees in question.

State of California Prevailing Wage Rates may be found at www.dir.ca.gov/Public-Works/Prevailing-Wage.html. Federal Minimum Wage Rates may be found at www.wdol.gov/wdol/scafiles/davisbacon/CA29.dvb

SP11-03 BUY AMERICA REQUIREMENTS

Furnish steel and iron materials to be incorporated into the work with certificates of compliance. Steel and iron materials must be produced in the U.S. except:

1. Foreign pig iron and processed, pelletized, and reduced iron ore may be used in the domestic production of the steel and iron materials [60 Fed Reg 15478 (03/24/1995)];
2. If the total combined cost of the materials does not exceed the greater of 0.1 percent of the total bid or \$2,500, materials produced outside the U.S. may be used.

Production includes:

1. Processing steel and iron materials, including smelting or other processes that alter the physical form or shape (such as rolling, extruding, machining, bending, grinding, and drilling) or chemical composition;
2. Coating application, including epoxy coating, galvanizing, and painting, that protects or enhances the value of steel and iron materials.

SP11-04 QUALITY ASSURANCE

The City's Quality Assurance Program (QAP) requirements are attached in **Appendix C**. The testing outlined in the QAP will be the minimum level of testing to ensure the materials delivered and produced comply with the Contract. Contractor may examine the records and reports of test that the City performs. Contractor shall schedule work to comply with the requirements of the City's QAP.

SP11-05 PROMPT PAYMENT OF FUNDS WITHHELD TO SUBCONTRACTORS

The City shall hold retainage from the prime contractor and shall make prompt and regular incremental acceptances of portions, as determined by the City, of the contract work, and pay retainage to the prime contractor based on these acceptances. The prime contractor, or subcontractor, shall return all monies withheld in retention from a subcontractor within 30 days after receiving payment for work satisfactorily completed and accepted including incremental acceptances of portions of the contract work by the City. Federal law (49CFR26.29) requires that any delay or postponement of payment over 30 days may take place only for good cause and with the City's prior written approval. Any violation of this provision shall subject the violating prime contractor or subcontractor to the penalties, sanctions and other remedies specified in Section 7108.5 of the Business and Professions Code. These requirements shall not be construed to limit or impair any contractual, administrative, or judicial remedies otherwise available to the prime contractor or subcontractor in the event of a dispute involving late payment or nonpayment by the prime contractor, deficient subcontract performance, or noncompliance by a subcontractor. This provision applies to both DBE and non-DBE prime contractors and subcontractors.

SPECIAL PROVISIONS SECTION SP-12

MOBILIZATION

(BID ITEM NO. 1)

The provisions of Section 1, "Mobilization", of the Technical Provisions and Section 6-21, "Environmental Responsibilities" of the General Provisions of the Standard Specifications shall apply in their entirety except as modified or supplemented herein.

The lump sum Contract Price paid for "**Mobilization**" shall include full compensation for furnishing all labor, supervision, materials, tools, equipment and incidentals, and for all the work involved in mobilization, including but not limited to- furnishing all specified contract bonds and insurance certificates; public notification; transporting materials and equipment; establishing a storage area and sanitary restroom facilities; installations at staging site; and all other work as specified in the Standard Specifications and these Special Provisions and as directed by the Engineer and no additional compensation shall be allowed therefor.

Compensation for providing and complying with the requirements for water pollution control, including furnishing all labor, supervision, materials, tools, equipment, and incidentals, and for doing all the work involved in installing, constructing, maintaining, removing, and disposing of water pollution control practices, including non-storm water management, and waste management and materials pollution water pollution control practices, and other necessary work shall be considered as included in the contract lump sum price paid for "Mobilization" and no additional compensation shall be allowed therefor.

SPECIAL PROVISIONS SECTION SP-13

CONSTRUCTION AREA SIGNS

(BID ITEM NO. 2)

SP13-01 GENERAL

Standard construction area signs shall be furnished, installed, and maintained at limits of Contract Work to warn and advise traffic approaching and moving through the work area. Signs shall be removed when no longer required, in accordance with Section 1-3, "Construction Area Signs", of the Technical Provisions.

SP13-02 MEASUREMENT AND PAYMENT

Payment for construction area signs shall be measured based on the number of sign panels installed regardless of the number of sign posts installed.

The Contract Price paid per each for "Construction Area Sign" shall be considered as full compensation for furnishing all labor, supervision, materials, tools, equipment and incidentals, and for doing all work involved in furnishing, installing, maintaining, and removing all construction area signs, as shown on the Plans, as specified in these Special Provisions, and as directed by the Engineer, and no additional compensation shall be allowed therefor.

SPECIAL PROVISIONS SECTION SP-14

TRAFFIC CONTROL

(BID ITEM NO. 3)

SP14-01 GENERAL

Traffic control shall conform to the requirements of Section 6-12, "Traffic Control", of the General Provisions of the Standard Specifications, and these Special Provisions. Nothing in these Special Provisions shall be construed as relieving the Contractor from his/her responsibilities as specified in said sections.

SP14-02 SUBMITTALS

Contractor is responsible for employing qualified personnel to develop a traffic control plan that is suitable for the Contract Work taking place and responds to the traffic setting and physical constraints of the construction area. Said plan shall include the use of at least two electronic

changeable message signs and two electronic “arrow boards.” All traffic control schemes shall be approved by the Engineer in advance of beginning any work deemed by the Engineer to require such traffic controls.

SP14-03 LANE CLOSURE

No road closure is allowed. Lane closures will be allowed between the hours of 9 a.m. and 5 p.m. Monday through Friday.

Emergency vehicles shall be provided with immediate access through the construction area at all times.

If work is not in progress during lane closure hours allowed and a traffic lane is closed, the Engineer may order the lane opened to public traffic.

Subject to all other provisions and restrictions of the Project Specifications, the following guidelines are provided as a convenience to Contractor to facilitate his preparation of a traffic control plan for the various stages and sequences of construction required to complete the Work:

1. Closure of one or more lanes is allowed provided that one lane of traffic is maintained for each direction of travel at all times.
2. Driveways shall not be closed for longer than 15 minutes unless the contractor has made prior arrangements in writing with the property owner and or impacted businesses. The Contractor shall provide written documentation of any arrangements for closures that have been made in advance of performing the work requiring a closure.

SP14-04 MEASUREMENT AND PAYMENT

The contract lump sum price paid for “**Traffic Control**” shall be considered as full compensation for furnishing all labor, supervision, materials, tools, equipment and incidentals needed to perform all traffic control work, for all phases of the work performed by the Contractor or the Contractor’s “subcontractors” including, but not limited to, signs of all kinds, barricades, steel plates, traffic control plan, detour plan, maintaining traffic, lane closures, detours, flagmen and all other traffic control devices; and all other work as shown on the State Standard Plans, as specified in the Standard Specifications, the State Specifications, these Special Provisions, and as directed by the Engineer and no additional compensation shall be allowed therefor. There shall be no additional compensation for traffic control due to an increase in the quantities shown on the bid proposal for pay items within the project limits.

Traffic Control required by work which is classified as extra work, as provided in Section 9.3, “Extra Work”, of the General Provisions of the Standard Specifications, will be paid for as part of said extra work.

The full costs of furnishing all flaggers under the provisions of this section and Sections 7-1.03, 7-1.04, and 12-1.03 of the State Specifications will be borne by the Contractor and shall be considered as included in the price paid for "Traffic Control" and no additional compensation shall be allowed therefor.

SPECIAL PROVISIONS SECTION SP-15

DUST CONTROL
(NO BID ITEM)

The provisions of Section 4, "Dust Control and Watering", of the Technical Provisions of the Standard Specifications shall apply in their entirety and as supplemented herein.

No separate payment shall be made for conforming to the provisions of this section. Full compensation for conforming to all the provisions of this section shall be considered as included in the prices paid for various contract items of work and no additional compensation shall be allowed therefor.

SPECIAL PROVISIONS SECTION SP-16

CLEARING, GRUBBING AND TREE PROTECTION
(BID ITEM NO. 4)

The provisions of Section 2, "Clearing and Grubbing," Section 22-3, "Tree and Plant Protection," of the Technical Provisions of the Standard Specifications shall apply in their entirety except as modified or supplemented herein.

SP16-01 GENERAL

In addition to requirements of the Standard Specifications, clearing and grubbing work shall also include miscellaneous removals as follows:

1. Sawcutting and removing existing asphalt concrete berm where in conflict with new installations as shown on the plans or as directed by the Engineer.
2. Removal of plastic delineators where in conflict in new installations as shown on the plans or as directed by the Engineer.
3. Salvaging all existing plastic K-rail-type barriers and delivering them to the Lafayette Corporation Yard at 3001 Camino Diablo, per Section 2-4 of the Standard Specifications Technical Provisions. Contractor shall replace all items damaged by his operations with in-kind items in new condition at his sole expense.

Removal operations shall protect the underlying pavement in sound condition to support the subsequent installation of new improvements. All cleared and grubbed areas shall be approved by the Engineer before further work commences.

SP16-02 MEASUREMENT AND PAYMENT

The contract lump sum price paid for “Clearing, Grubbing and Tree Protection” shall include full compensation for furnishing all labor, supervision, materials, tools, equipment and incidentals, and for doing all the work involved in clearing, grubbing, tree protections where required, miscellaneous removals and salvaging, and all other work as shown on the Plans, as specified in the Standard Specifications, these Special Provisions, and as directed by the Engineer, and no additional compensation shall be allowed therefor.

SPECIAL PROVISIONS SECTION SP-17

RAILINGS AND BARRIERS

(BID ITEM NO. 5, 6)

All work shall conform to the requirements of Section 83, “Railings and Barriers,” of the State Specifications, and applicable State Standard Plans, and as shown on the Plans and as directed by the Engineer.

SP17-01 GENERAL

Work shall include installation of concrete barriers and metal beam guard rail at locations and to the limits as shown on the Project Plans.

Concrete barriers shall be Type 60C to accommodate potential offsets in pavement and/or adjacent surfaces, installed with cemented markers in conformance with manufacturer’s recommendations. Guard rails shall be installed with wood posts, blocks, and Corten-treated rail.

All components, including all hardware, shall be new and conforming to applicable State Standard Specifications. All hardware other than the metal rails shall be galvanized and conforming to ASTM A242. Bolt heads and washers for guard rails shall be painted brown to match the Corten rails.

SP17-02 SUBMITTAL

End sections for guard rails shall be the in-line or flared treatment type as required by the Plans and conforming to the applicable State Standard Plans. Contractor shall submit a system from a manufacturer that has been prequalified and tested to be used by the State of California Department of Transportation (Caltrans) within District 4. If no such manufacturer exists, Contractor shall submit a system of products that have been accepted for installation by Caltrans within District 4 within the past two years and still operating in satisfactory functional condition.

Subject to confirmation by Contractor and concurrence of the Engineer regarding compliance of the above provisions, City may accept one of the following:

1. (In-Line) TYPE ET-31 TERMINAL SYSTEM - Type ET-31 terminal system must be an ET-31 (4-tube system) extruder terminal, system length 53'-1-1/2", as manufactured by Trinity Highway Products, LLC. The ET-31 PLUS (4-tube system) extruder terminal can be obtained from the manufacturer, Trinity Highway Products, LLC, P.O. Box 99, Centerville, UT 84012, telephone (800) 772-7976. <http://highwayguardrail.com/products/etplus.html>

2. (In-Line) TYPE SKT-SP-MGS for steel posts or Type SKT-W-MGS for wood posts TERMINAL SYSTEM - Type SKT-MGS terminal system must be a SKT 350 sequential kinking terminal, system length 53'-1-1/2", manufactured by Road Systems, Inc., located in Big Spring, Texas. The SKT 350 sequential kinking terminal can be obtained from the distributor, Universal Industrial Sales, P.O. Box 699, Pleasant Grove, UT 84062, telephone (801) 785-0505 or from the distributor, Gregory Highway Products, 4100 13th Street, S.W., Canton, OH 44708, telephone (330) 477-4800. <http://www.roadsystems.com/skt.html>
3. (In-Line or Flared) TYPE 31" X-TENSION - Type 31" X-Tension terminal system must be a 31" X-Tension Guard Rail End Terminal as manufactured by Barrier Systems, Inc., located in Vacaville, CA. The 31" X-Tension Guard Rail End Terminal can be obtained from the distributor, Statewide Safety and Signs, Inc., 130 Grobric Court, Fairfield, CA 94533, telephone (800) 770-2644. <http://www.barriersystemsinc.com/xtension-guardrail-end-treatment>
4. (Flared) TYPE SRT-31 TERMINAL SYSTEM - Type SRT-31 terminal system must be an SRT-350 Slotted Rail Terminal (6-postsystem), system length 37'-6", as manufactured by Trinity Highway Products, LLC. The SRT-350 Slotted Rail Terminal (6-post system) can be obtained from the manufacturer, Trinity Highway Products, LLC, P.O. Box 99, Centerville, UT 84012, telephone (800) 772-7976. <http://highwayguardrail.com/products/et-srt350.html>
5. (Flared) TYPE FLEAT-SP-MGS for steel or FLEAT-W-MGS for wood TERMINAL SYSTEM – Type FLEAT-MGS terminal system must be a Flared Energy Absorbing Terminal 350, system length 37'-6", manufactured by Road Systems, Inc., located in Big Spring, Texas. The Flared Energy Absorbing Terminal 350 can be obtained from the distributor, Universal Industrial Sales, P.O. Box 699, Pleasant Grove, UT 84062, telephone (801) 785-0505 or from the distributor, Gregory Industries, Inc., 4100 13th Street, S.W., Canton, OH 44708, telephone (330) 477-4800. <http://www.roadsystems.com/fleat.html>

Prior to installation, the Contractor shall provide a Certificate of Compliance from the manufacturer of products to be furnished certifying that they conform in every way to the Contract and approved submittals in design, material requirements, and manufacturing quality control. Contractor shall not knowingly install a system that does not comply with current codes, professional guidelines or standards, and/or best practices.

SP17-03 INSTALLATION

Concrete Barrier

Concrete barrier shall be founded on sound pavement or compacted base. Where barrier is to be located adjacent to an embankment in fill condition, a minimum clearance of 6 inches from the hinge point shall be achieved. If necessary, Contractor shall perform minor grading and/or placement of compacted fill to accommodate the barrier placement conforming to these Special Provisions. Imported materials shall be Class 2 aggregate base conforming to Section 8 of the Standard Specifications Technical Provisions, including materials and compaction requirements.

At the limit of new barrier installation, the new barrier shall neatly align and conform to the face of existing adjacent berms and dikes in a smooth alignment. Coincidental to Contract Work, Contractor

shall install short sections of asphalt or concrete berms, minimum five-foot long, to achieve a conform satisfactory to the Engineer. Berm installation shall conform to Section SP 18 of these Special Provisions.

Metal Guard Rail

Prior to installation Contractor shall make a submittal on the in-line treatment type to be used for the guard rail end section. The proposed installation shall be in wide use within the Caltrans District 4 Region. The submittal shall sufficiently detail the major components and assembly of the end section

All materials needed to complete the construction shall be on-site before beginning the guard rail work. All post holes shall be augured, unless another method is approved by the Engineer. All holes, except end post holes, shall be backfilled with Class II aggregate base conforming to SP-19. Backfill material shall be moisture treated and compacted by hand-tamping. End posts shall be backfilled with concrete of Class 590-C-3250 conforming to Section 17 of the Standard Specifications Technical Provisions.

SP17-04 PAYMENT

The contract prices paid per linear foot for “Concrete Barrier” and “Metal Beam Guard Rail” shall include full compensation for furnishing all labor, supervision, materials, tools, equipment and incidentals needed to complete the work, including but not limited to- potholing for utilities, minor grading and compaction to achieve an adequate base, furnishing and installing posts, blocks, corten-treated rail, end sections, backfill, painting, placement of minor berm/dike conforms, and all other work as shown on the Plans and the State Standard Plans, as specified in these Special Provisions, as directed by the Engineer, and no additional compensation shall be allowed therefor.

SPECIAL PROVISIONS SECTION SP-18

BERM/DIKE

(NO BID ITEM)

Dikes shall match dimensions and shapes of the adjacent existing facility to which the new installation conforms. All dikes not adjacent to new paved driveways or pathways shall be backfilled on the back side with clean materials matching the existing surrounding ground.

For asphalt dikes, the provisions of Section 9, “Asphalt Concrete,” of the Technical Provisions of the Standard Specifications shall apply in its entirety except as modified or supplemented herein.

Prior to placement of the dike, the underlying pavement shall be thoroughly cleaned and a tack coat per Standard Specifications Technical Provisions Section 9-11 shall be applied to the pavement surface. The Contractor shall protect newly-placed dike to allow sufficient time for curing. Dikes that slough, fall apart, or otherwise become damaged before curing shall be completely removed and replaced at the Contractor’s expense. If a section of dike looks “patched,” it shall be entirely removed and replaced with a conforming dike that is smooth and uniform in appearance.

At Contractor’s option, and for his own convenience, Contractor may elect to install concrete curb where berms and dikes are required to transition and conform barriers to existing asphalt dikes.

Concrete used for curb shall conform to Section 17, "Concrete Construction," of the Standard Specifications Technical Provisions. Concrete shall incorporate "lamp black" at a rate of no less than 4 pounds per cubic yard.

There shall be no separate measurement or payment for labor, materials, and equipment to construct asphalt or concrete berms and dikes and related work. Full compensation shall be considered as included in the contract unit price paid for other items of work in the Contract.

SPECIAL PROVISIONS SECTION SP-19 to 23 (NOT USED)

SPECIAL PROVISIONS SECTION SP-24

HIGH-FRICTION SURFACE TREATMENT

(BID ITEM NO. 7)

SP24-01 GENERAL

High friction surface treatment (HFST) installation onto an asphalt concrete pavement consists of a polymer resin binder with a calcined bauxite aggregate topping.

SP24-02 SUBMITTALS

Contractor shall submit a HFST Quality Control Plan (QCP) at least five (5) working days prior to beginning work.

The HFST QCP must include:

1. Assessment of existing pavement conditions, including the need for cleaning and/or sandblasting if determined to be required for sufficient bonding
2. Schedule for the HFST work
3. Description of equipment for placing HFST
4. Description of equipment for measuring, mixing, placing, and finishing HFST
5. Method for protecting areas not to receive HFST
6. Cure time estimates for HFST
7. A correction plan for HFST that fails to meet the coefficient of friction of 0.75. The correction plan may include correction of existing HFST or removal and replacement.
8. Storage and handling of HFST components
9. Disposal of excess HFST and containers
10. Contingency plan for possible failure during the HFST application
11. Name of the certified independent testing laboratory
12. Traffic control plan for application and curing of HSFT

Contractor shall submit a material safety data sheet (MSDS) for each shipment of HFST components and a certificate of compliance for the polymer resin binder and the calcined bauxite aggregate topping.

Contract shall allow only polymer resin binder and calcined bauxite aggregate topping that have been tested at a certified independent testing laboratory. Contractor shall furnish proof of verifications that the materials meet all requirements listed in these Specifications, dated no earlier than three (3) months from the time of Contract Award.

SP24-03 MATERIALS

Polymer Resin Binder

Contractor shall provide a two-part exothermic polymer resin binder which holds the aggregate topping firmly in place, and which meets the requirements of Table 1.

**Table 1
Polymer Resin Binder Requirements**

Property	Requirement	Test Method
Ultimate Tensile Strength	2650 psi min.	ASTM D638
Elongation at break point	30% min.	ASTM D638
Compressive Strength	1600 psi min.	ASTM D695
Water Absorption	1.0 % max.	ASTM D570
Shore D Hardness, min. 77°F	65-75	ASTM D2240
Viscosity	1000-3000 Pa	ASTM D2393
Gel Time, minutes	15-45 min.	ASTM C881
Cure Rate	3 hrs. max.	ASTM D1640, 0.2" thickness
Mixing Ratio	As recommended by manufacturer	N/A

Aggregate Topping

Contractor shall furnish a blend of calcined bauxite aggregate. The aggregate topping is to be clean, dry, and free from deleterious matter. The aggregate topping must meet the requirements of Table 2.

**Table 2
Aggregate Topping Requirements**

Property	Test Method	Requirement
Aggregate Grading	CTM 202	No. 6 Percentage Passing 95% min. No.16 Percentage Passing 5% max.
Aggregate Abrasion Value Loss at 100 rev.	CTM 211	10% max.
Aggregate Acid Insolubility	ASTM D3042	Greater than 90%
Aggregate Magnesium Soundness	ASTM C88	30% max.

SP24-04 CONSTRUCTION

Contractor shall ensure that the HFST supplier and crew foreman are present at all times during the installation process.

All pavement markers and delineation within the installation area shall be removed prior to placement of the binder. Pavement surfaces must be clean, dry, and free of all dust, oil, debris and any other material that might interfere with the bond between the polymer resin binder material and existing surfaces. Adequate cleaning of all surfaces shall be the sole judgment of the Engineer, whose decision shall not relieve the Contractor of his responsibility for installing a product conforming to all requirements of these Special Provisions.

The HFST installation must conform to the following:

1. Do not apply the polymer resin binder on a wet surface or when the ambient temperature is below 55°F or when the anticipated weather conditions would prevent the proper application of the surface treatment as determined by the Engineer.
2. Surface preparation work, surface temperature, placement of the HFST must be in conformance with the binder supplier's specifications, these Special Provisions, and as approved by the Engineer.
3. The spread rate for polymer resin binder is 0.28-0.32 gal/sq yd.
4. The spread rate of retained aggregate is 13-20 lb/sq yd.
5. Polymer resin components must be thoroughly mixed prior to application, then uniformly applied to the prepared surface by a mechanical method.
6. Automated continuous application must be performed by applicator equipment. The applicator must heat, continuously mix, meter, monitor and apply the polymer resin binder.
7. Hand application is allowed on areas under 200 square feet
8. HFST must be allowed to cure for the minimum duration as recommended by the supplier's specifications and during that time the application area must be closed to all vehicle and Contractor equipment traffic.
9. The surface texture of the HFST must be uniform and have a coefficient of friction not less than 0.75 as tested by ASTM E1911.

Excess and loose aggregate must be removed from the traveled way and shoulders by street sweeping. A second street sweeping shall occur 24 hours after application.

Utilities, drainage structures, curbs, and any other structures within or adjacent to the treatment location must be protected against the application of the HFST materials.

Upon completion of curing, Contractor shall test for the coefficient of friction per ASTM E1911 and provide results to the Engineer. Testing shall be at the Contractor's expense, regardless of number of tests required to achieve compliance with Contract. Failure to meet the specified friction shall trigger corrective actions in the plan submitted by the Contractor.

SP24-05 MEASUREMENT AND PAYMENT

The contract unit price paid per square yard for "**High-Friction Surface Treatment**," shall be considered as full compensation for furnishing all labor, materials, tools, equipment and incidentals

and for doing all the work involved in installing the treatment, including but not limited to- all submittals, all pavement cleaning and preparation, protecting utility and roadway facilities, applying the treatment, testing, protection during curing, street sweeping, all corrective measures, and all other incidental work required to complete the work as shown and specified.

SPECIAL PROVISIONS SECTION SP-25
TEMPORARY PAVEMENT DELINEATION
(NO BID ITEM)

The provisions of Section 6-12.7, "Temporary Traffic Striping and Pavement Markings", of the General Provisions of the Standard Specifications shall apply in their entirety except as modified or supplemented herein.

There shall be no separate measurement or payment for labor, materials, and equipment to install temporary pavement delineation. Full compensation shall be considered as included in the contract unit price paid for other items of work in the Contract.

SPECIAL PROVISIONS SECTION SP-26
SIGNING AND STRIPING
(BID ITEM NO. 8)

The provisions of Section 15, "Pavement Striping, Markers, and Delineation," and Section 16, "Traffic Signs," of the Technical Provisions of the Standard Specifications shall apply in their entirety except as modified or supplemented herein.

SP26-01 GENERAL

Work shall include installation of signs and stripes as shown on the Contract Plans, replacement of pre-existing pavement stripes and markings removed for the installation of HFST (whether shown on the Contract Plans or not), and new stripes, marking, markers, and delineators incidental to the installation concrete barriers and metal beam guard rail as shown on the applicable State Standard Plans.

Pavement stripes and markings shall be installed in thermoplastic.

SP26-02 MEASUREMENT AND PAYMENT

The contract lump-sum price paid for "**Signing and Striping**" shall include full compensation for furnishing all labor, materials, tools, equipment and incidentals and for doing all the work involved in placing traffic stripes, markings, markers, signs, and delineators of all kinds, including any necessary cat tracks, dribble lines and layout work, cleaning and preparing surfaces to receive striping, posts, hardwares, and foundations for signs, and all other work as shown on the Plans, the State Standard Plans, and as specified in the Standard Specifications, the State Specifications, and these Special Provisions, and as directed by the Engineer and no additional compensation shall be allowed therefor.

APPENDIX A

**WASTE MANAGEMENT PLAN
AND
WASTE ASSESSMENT FORM**

WASTE ASSESSMENT FORM

(To be filled out and submitted to the Engineer before commencing demolition work)

The table below lists debris materials that are routinely generated during construction or demolition. Identify the materials that you estimate will be recycled, salvaged, or landfilled from your project site and the handling procedure, hauler and/or destination of each material type.

Material Type	Identify Materials (☑)			Handling Procedure, Hauler, or Final Destination of Material
	Recycle	Salvage	Landfill	
Asphalt				
Brick				
Concrete				
Dirt/Clean Fill				
Masonry				
Metals (steel, brass, aluminum, copper, etc.)				
Rock/Stone				
Vegetative Debris				
Wood/Lumber				
Other:				
Garbage				

Please sign and date attesting that the above information is true and correct to the best of your knowledge, that you acknowledge that 40% of your contract retention may be forfeited to the City for failure to meet the 50 percent diversion requirement, and that you are responsible for the actions of your subcontractors or other agents with regard to the diversion requirement.

CONTRACTOR NAME: _____

SIGNATURE: _____

DATE: _____

WASTE ASSESSMENT SUMMARY REPORT FORM

(To be filled out upon project completion)

Complete the table below by indicating what was actually done with all the C&D materials from the project and the quantities (by weight) that were recycled, salvaged, or landfilled. All C&D materials must be accounted for whether or not they were recycled or taken to the landfill. Attach receipts and weight tags from all recyclers and landfill locations identifying, 1) date, 2) project number, 3) material type, 4) if materials were recycled, salvaged, or landfilled, and 5) weight of load(s).

Material Type	Identify Materials (T)			Handling Procedure, Hauler, or Final Destination of Material
	Recycle	Salvage	Landfill	
Asphalt				
Brick				
Concrete				
Dirt/Clean Fill				
Masonry				
Metals (steel, brass, aluminum, copper, etc.)				
Rock/Stone				
Vegetative Debris				
Wood/Lumber				
Other:				
Garbage				

Please sign and date attesting that the above information is true and correct to the best of your knowledge, that you acknowledge that 40% of your contract retention may be forfeited to the City for failure to meet the 50 percent diversion requirement.

CONTRACTOR NAME: _____

SIGNATURE: _____

DATE: _____

RECEIPT FOR MATERIALS RECYCLED

(To be filled out by receiver only if facility does not issue an itemized receipt)

Company or Individual Receiving Material: *(Business stamp is acceptable)*

Company:			
Address:			
City:			
Zip:			
Phone:			
Facility/Individual Type: <i>(Circle one)</i> Recycler Salvager End User			
Facility Attendant Signature: <i>(Required)</i>			

Construction/Demolition Company: *(Business stamp is acceptable)*

Company:	
Address:	
City:	
Zip:	
Phone:	Contact:

Materials Received:

Material Type	Amount <i>(specify in cubic yards, lbs, or tons)</i>	Cost <i>(or payment if applicable to service)</i>	Intended Use of Material Received <i>(circle one)</i>	Date Received or Picked Up
			Recycle Reuse Salvage Landfill	
			Recycle Reuse Salvage Landfill	
			Recycle Reuse Salvage Landfill	
			Recycle Reuse Salvage Landfill	

APPENDIX B

STANDARD PLANS

Randall D. Hiett

October 30, 2015

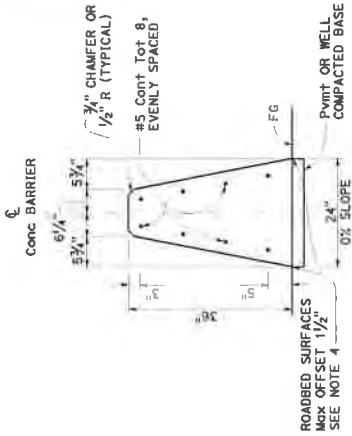
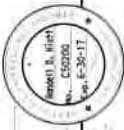

CONCRETE BARRIER TYPE 60

NOTES:

1. See Standard Plan A76B for details of Concrete Barrier Type 60 and anchors, connection to structures and transitions to Concrete Barrier Type 50 and Concrete Barrier Type 60S.
2. See Standard Plan A76C for Concrete Barrier Type 60 transitions at bridge column and sign pedestals.
3. Where glare screen is required on Concrete Barrier Type 60, use Concrete Barrier Type 60C.
4. Where roadbed offset is greater than 1/2", see Concrete Barrier Type 60C.
5. See Project Plans for barrier delineation locations.
6. Reinforcing stirrup not required for roadbed offsets less than 1'-0".
7. For roadbed surfaces offset greater than 1 1/2" and less than or equal to 3", no reinforcement required. For roadbed surfaces offset greater than 3" and less than or equal to 8", use two #4 reinf at 3" above the lower roadbed surface. For roadbed surfaces offset greater than 8" and less than or equal to 12", use two #4 reinf at 3" above the lower roadbed surface. For roadbed surfaces offset greater than 12" and less than or equal to 36", use two #4 reinf at 3" above the lower roadbed surface and two #4 reinf at every 8" increment vertical spacing above the first two #4 reinf.

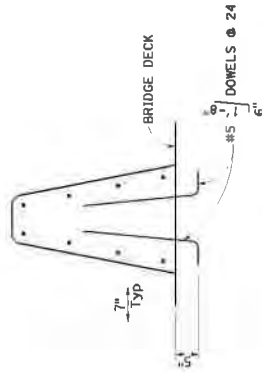

CONCRETE BARRIER TYPE 60A

Details similar to Type 60 except as noted.

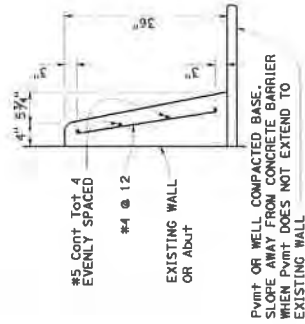

CONCRETE BARRIER TYPE 60C

Details similar to Type 60 except as noted.

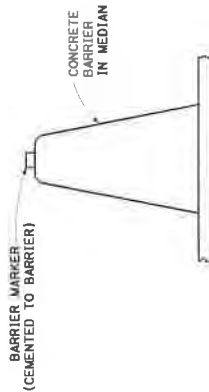

CONCRETE BARRIER TYPE 60 DELINEATION

See Note 5

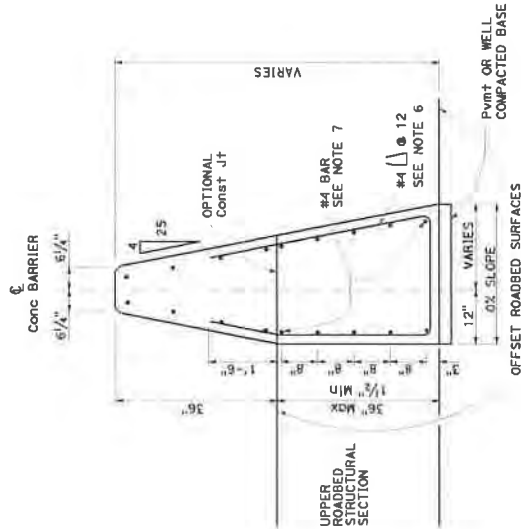

CONCRETE BARRIER TYPE 60C

Details similar to Type 60 except as noted. Use concrete barrier and anchor when necessary. 36" roadbed surfaces offset shown.

STATE OF CALIFORNIA
DEPARTMENT OF TRANSPORTATION

CONCRETE BARRIER TYPE 60

NO SCALE

A76A

Randall D. Hartz
 October 30, 2015
 HERRI B. HERT
 No. C50200
 Exp. 6-30-17

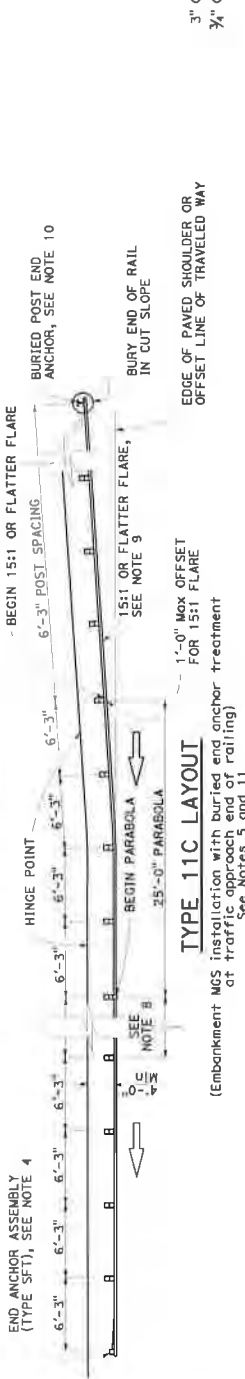
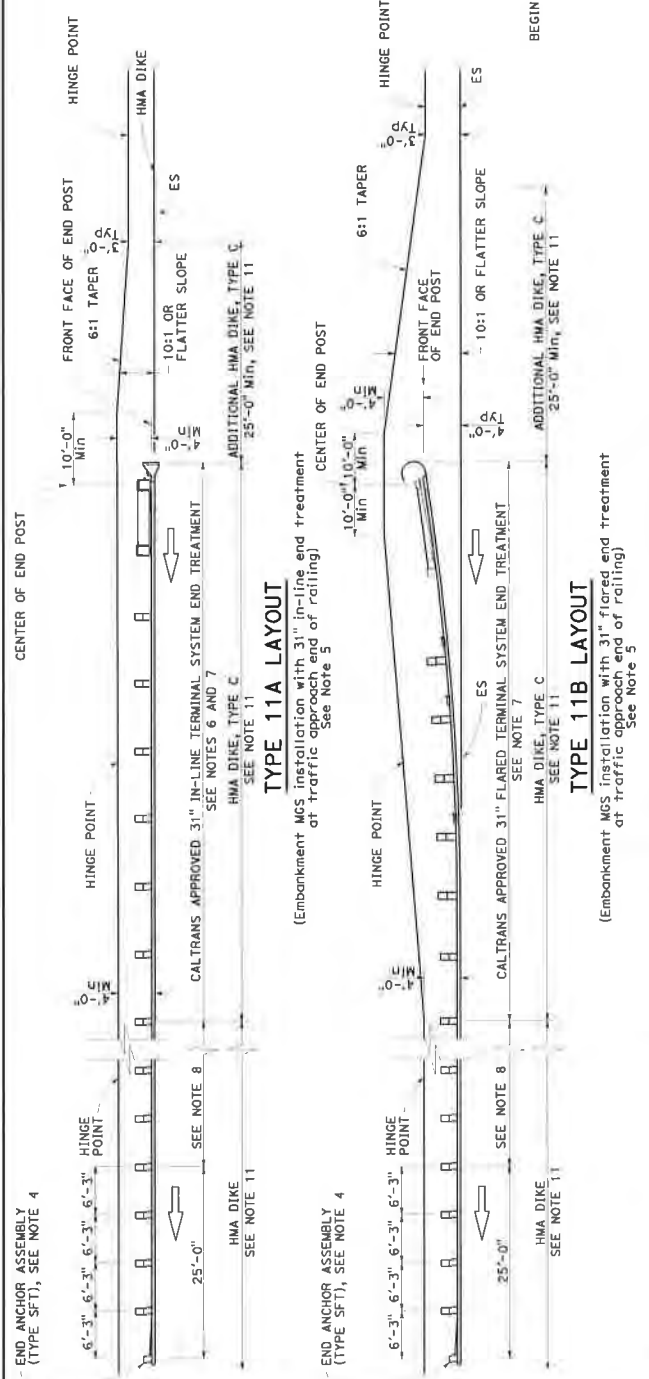

NOTES:

- Line post, blocks and hardware to be used are shown on Standard Plans A77L1, A77L2, A77M1, A77N1 and A77N2.
- MCS post spacing to be 6'-3" center to center, except as otherwise noted.
- Except as noted, line posts are 6" x 6" x 6'-0" wood post with 5" x 12" x 12" wood blocks. W6 x 8.5 or W6 x 9 steel posts, 6'-0" in length, with 12" x 12" x 12" wood blocks. Or, recycled plastic blocks may be used for 6" x 8" posts and 6" x 12" x 12" wood blocks where applicable and when specified.
- For End Anchor Assembly (Type SFT) details, see Standard Plan A77S1.
- Layout Types 11A, 11B or 11C are typically used where MCS is recommended to shield embankment slopes and a crashworthy end treatment is required for only one direction of traffic.
- 31" in-line terminal system end treatments are used where site conditions will not accommodate a flared end treatment.
- The top of 31" terminal system end treatment to be used will be shown on the Project Plans.
- Dependent on site conditions (embankment height and side slope), construction spacing of MCS posts equal to multiples of 12'-6" with 6'-3" post spacing may be advisable.
- The 15:1 or flatter flare used with buried end anchors is based on the edge of the paved shoulder or offset line of edge of the traveled way. The length of MCS within the 15:1 or flatter flare is based on site conditions and should be a length equal to multiples of 12'-6".
- For details of the buried post end anchor used with Type 11C Layout, see Standard Plan A77T2.
- Where placement of dike is required with MCS installations, see Standard Plan A77N4 for dike positioning details.

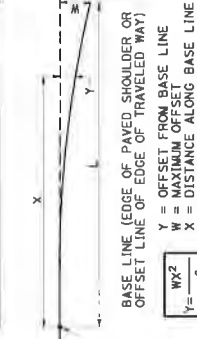
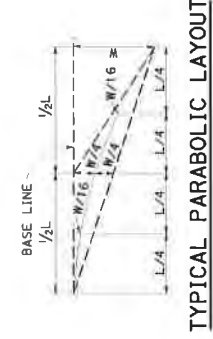

TYPICAL FLARE OFFSETS FOR 1 FOOT MAX END OFFSET

MIDWEST GUARDRAIL SYSTEM TYPICAL LAYOUTS FOR EMBANKMENTS
 NO SCALE

STATE OF CALIFORNIA
 DEPARTMENT OF TRANSPORTATION

A77P1

Randall D. Hiett
 REGISTERED CIVIL ENGINEER
 October 30, 2015

NOTES:

1. When necessary to place dike more than 7" in front of face of MGS, only Type C dike may be used. For dike details, see Standard Plan A87B.
2. For standard railing post embedment, see Standard Plan A77N3.
3. MGS delineation to be used where shown on the Project Plans.
4. When dike or curb is placed under MGS, the maximum height of the dike or curb shall be 6". Mountable dike should not be used. For dike and curb details, see Standard Plans A87A and A87B.
5. For details of typical distance between the face of rail and hinge point, see Standard Plan A77N3.
6. For steel line posts, use 1/4" - 20 self-tapping screws in 0.22" diameter holes or 1/4" bolts in 3/8" diameter holes.

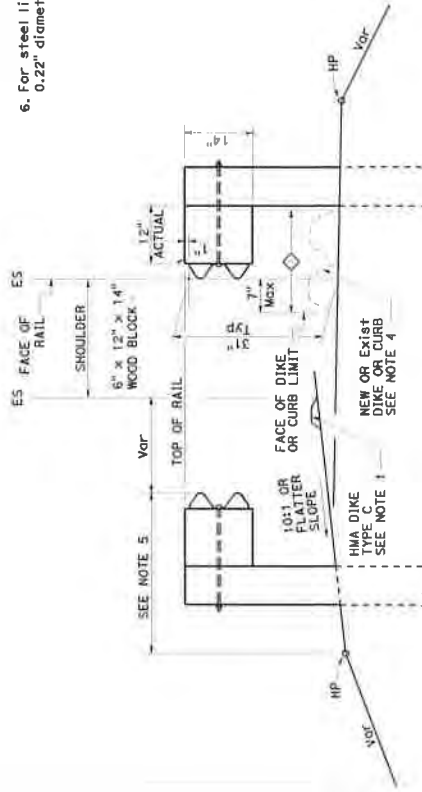

DIKE POSITIONING

See Note 1

◇ PERMISSIBLE DIKE OR CURB PLACEMENT AREA

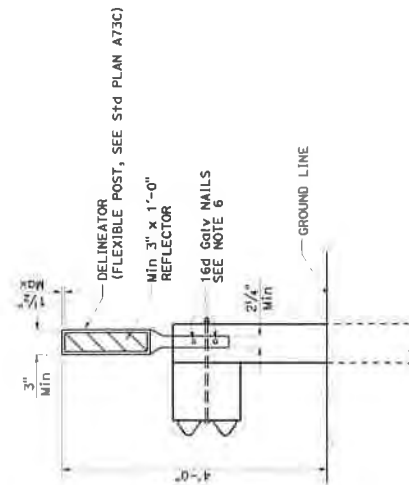

MGS DELINEATION

See Note 3

STATE OF CALIFORNIA
DEPARTMENT OF TRANSPORTATION

**MIDWEST GUARDRAIL SYSTEM
TYPICAL RAILING DELINEATION
AND DIKE POSITIONING DETAILS**

NO SCALE

A77N4

APPENDIX C

CITY OF LAFAYETTE QUALITY ASSURANCE PROGRAM (QAP)

QUALITY ASSURANCE PROGRAM (QAP)

AGENCY: City of Lafayette

The purpose of this program is to provide assurance that the materials incorporated into the construction projects are in conformance with the contract specifications. This program should be updated every five years or more frequent if there are changes of the testing frequencies or to the tests themselves. To accomplish this purpose, the following terms and definitions will be used:

DEFINITION OF TERMS

- Acceptance Testing (AT) – Sampling and testing, or inspection, to determine the degree of compliance with contract requirements.
- Independent Assurance Program (IAP) – Verification that AT is being formed correctly by qualified testers and laboratories.
- Quality Assurance Program (QAP) – A sampling and testing program that will provide assurance that the materials and workmanship incorporated into the construction project are in conformance with the contract specifications. The main elements of a QAP are the AT, and IAP.
- Source Inspection – AT of manufactured and prefabricated materials at locations other than the job site, generally at the manufactured location.
- LAPM – Caltrans Local Assistance Procedures Manual

MATERIALS LABORATORY

The AGENCY will use a private consultant materials laboratory to perform AT on Federal-aid or other designated projects. The materials laboratory shall be under the responsible management of a California registered Engineer with experience in sampling, inspection and testing of construction materials. The Engineer shall certify the results of all tests performed by laboratory personnel under the Engineer's supervision. The materials laboratory shall contain certified test equipment capable of performing the tests confirming to the provisions of this QAP.

The materials laboratory used shall provide documentation that the laboratory complies with the following procedures:

1. Correlation Testing Program – The materials laboratory shall be a participant in one or more of the following testing programs:
 - a. AASHTO Materials Reference Laboratory (AMRL)
 - b. Cement and Concrete Reference Laboratory (CCRL)
 - c. Caltrans' Reference Samples Program (RSP).
2. Certification of Personnel – The materials laboratory shall employ personnel who are certified by one or more of the following:
 - a. Caltrans District Materials Engineer
 - b. Nationally recognized non-Caltrans organizations such as the American Concrete Institute, Asphalt Institute, National Institute of Certification of Engineering Technologies, etc.
 - c. Other recognized organizations approved by the State of California and/or recognized by local governments or private associations.
3. Laboratory and Testing Equipment – The materials laboratory shall only use laboratory and testing equipment that is in good working order. All such equipment shall be calibrated at least once each year. All testing equipment must be calibrated by impartial means using devices of accuracy traceable to the National Institute of Standards and Technology. A decal shall be firmly affixed to each piece of equipment showing the date of the last calibration.

ACCEPTANCE TESTING (AT)

AT will be performed by a materials laboratory certified to perform the required tests. The tests results will be used to ensure that all materials incorporated into the project are in compliance with the contract specifications.

Testing methods will be in accordance with the CT Methods or a national recognized standard (i.e., AASHTO, ASTM, etc.).

Sample locations and frequencies may be in accordance with the contract specifications. If not so specified in the contract specifications, samples shall be taken at the locations and frequencies as shown in Appendix A, "Acceptance Sampling and Testing Frequencies" of this QAP Manual.

INDEPENDENT ASSURANCE PROGRAM (IAP)

Poor correlation between acceptance tester's results and other test results may indicate probable deficiencies with the acceptance sampling and testing procedures. In cases of unresolved discrepancies, a complete review of AT shall be performed by IAP personnel, or an independent materials laboratory chosen by the Agency. IAP samples and tests are not be used for determining compliance with contract requirements. Compliance with contract requirements is determined only by AT.

IAP shall be provided by personnel from Caltrans or consultant's certified materials laboratory. IAP will be used to verify that sampling and testing procedures are being performed properly and that all testing equipment is in good condition and property calibrated.

IAP personnel shall be certified in all required testing procedures, as part of IAP, and shall not be involved in any aspect of AT.

IAP shall be performed on every type of materials test required for the project. Proficiency tests shall be performed on Sieve Analysis, Sand Equivalent, and Cleanness Value tests. All other types of IAP shall be witness tests.

REPORTING ACCEPTANCE TESTING RESULTS

The following are time periods for reporting material test results to the Resident Engineer:

- When the aggregate is sampled at material plants, test results for Sieve Analysis, Sand Equivalent and Cleanness Value should be submitted to the Resident Engineer within 24 hours after sampling.
- When materials are sampled at the job site, test results for compaction and maximum density should be submitted to the Resident Engineer within 24 hours after sampling.
- When soils and aggregates are sampled at the job site:
 1. Test results for Sieve Analysis, Sand Equivalent and Cleanness Value should be submitted to the Resident Engineer within 72 hours after sampling.
 2. Test results for "R" Value and asphalt concrete extraction should be submitted to the Resident Engineer within 96 hours after sampling.

When sampling products such as Portland Cement Concrete (PCC), cement-treated base (CTB), hot mix asphalt (HMA), and other such materials, the time of such sampling shall be varied with respect to the time of the day insofar as possible, in order to avoid a predictable sampling routine. The reporting of AT results, if not performed by the Resident Engineer's staff, shall be done on an expedited basis such as by fax, email, or telephone.

TESTING OF MANUFACTURED MATERIALS

During the Design phase of the project, the Project Engineer may submit a "Source Inspection Report" (see Attachment #2 – Exhibit 16-V of the Caltrans LAPM) to the Agency, consultant, or Caltrans for inspection and testing of manufactured and prefabricated materials by their materials laboratory. Materials that can be

typically accepted on the basis of certificates of compliance are shown in Appendix A, "Acceptance Sampling and Testing Frequencies" of this QAP Manual.

For Federal-aid projects on the National Highway System (NHS), Caltrans will assist in certifying the materials laboratory, and the acceptance samplers and testers. For Federal-aid projects off the NHS, Caltrans may be able to assist in certifying the materials laboratory, and the acceptance samplers and testers.

MINOR QUANTITIES

Relatively minor quantities of materials from a known, reliable source may be accepted without testing if:

1. The City Inspector performs visual examining of materials, or
2. The manufacturer or supplier certifies that the material furnished complies with specification requirements.

Such records of acceptance shall be placed in the City Inspector's project files with related inspection notes.

Examples of maximum "Minor Quantities" found in Appendix A- Acceptance Sampling and Testing Frequencies include:

- Freshly Mixed Concrete: 500 CY per project
- Bituminous mixtures: 500 foot long project street

PROJECT CERTIFICATION

Upon completion of a Federal-aid project, a "Materials Certificate" shall be completed by the Resident Engineer. The Agency shall include a "Materials Certificate" in the Report of Expenditures submitted to the Caltrans District Director, Attention: District Local Assistance Engineer. A copy of the "Materials Certificate" shall also be included in the Agency's construction records. The Resident Engineer in charge of the construction function for the Agency shall sign the certificate. All materials incorporated into the work which did not conform to specifications must be explained and justified on the "Materials Certification", including changes by virtue of contract change orders.

RECORDS

All material records of samples and tests, material releases and certificates of compliance for the construction project shall be incorporated into the Resident Engineer's project file. If a Federal-aid project:

- The files shall be organized as described in Section 16.8 "Project Files" of the Local Assistance Procedures Manual.
- It is recommended that the complete project file be available at a single location for inspection by Caltrans and Federal Highway Administration (FHWA) personnel.
- The project files shall be available for at least three years following the date of final project voucher.

When two or more projects are being furnished with identical materials simultaneously from the same plant, it is not necessary to take separate samples or perform separate tests for each project; however, copies of the test reports are to be provided for each of the projects to complete the records.

APPROVED BY: _____ 48930 9/30/2016
 (Signature) (CE# and Expiration Date)

NAME: Tony Coe DATE: 12/17/14

TITLE: Engineering Services Manager, City of Lafayette

Appendix A – Acceptance Sampling and Testing Frequencies

Materials to be sampled or tested	Sample Size	Sampling/Testing Frequency	Typical Test Methods	Comments
Cement/Fly Ash		Accept based on Certificate of Compliance.		
Cement		Accept based on Certificate of Compliance.		
Aggregate for Hydraulic Cement Concrete	50-lb. sample	One sample for each 1,000 CY of PCC/HCC concrete. If less than 1,000 CY then accept based on Certificate of Compliance.	ASTM D75 CT 125 AASHTO M6, T2, M80	Sample aggregate randomly from belt or hopper.
Water for Concrete		Accept based on Certificate of Compliance or Test Results.		Chlorides and Sulfates must be less than 1%.
Air Entraining Admixture		Accept based on Certificate of Compliance.		
Water Reducers or Set Retarders		Accept based on Certificate of Compliance.		
Freshly Mixed Concrete	Approx. 150 lb. or 1 CF near mixer discharge	If total job quantity is less than 500 CY, then accept based on Certificate of Compliance. If job is greater than 500 CY, test at least one sample per job.	ASTM C172, C685, CT 539, AASHTO T141, M157	Describes sampling method.
Freshly Mixed Concrete	Approx. 150 lb. or 1 CF near mixer discharge	If total job quantity is less than 500 CY, then accept based on Certificate of Compliance If job is greater than 500 CY, test at least one sample per job.	ASTM C143, AASHTO T119, ACI 318-08	Determines slump.
Freshly Mixed Concrete	Approx. 150 lb. or 1 CF near mixer discharge	If total job quantity is less than 500 CY, then accept based on Certificate of Compliance. If job is greater than 500 CY, test at least one sample per job.	ASTM C231, CT 504, AASHTO T121, ACI 318-08	Determines air content (pressure method).

Appendix A – Acceptance Sampling and Testing Frequencies

Portland Cement Concrete (Hydraulic Cement Concrete)

Materials to be sampled or tested	Sample Size	Sampling/Testing Frequency	Typical Test Methods	Comments
Freshly Mixed Concrete	Approx. 150 lb. or 1 CF near mixer discharge	If total job quantity is less than 500 CY, then accept based on Certificate of Compliance. If job is greater than 500 CY, test at least one sample per job.	ASTM C138, CT 518, AASHTO T121	Determines unit weight.
Freshly Mixed Concrete	Approx. 150 lb. or 1 CF near mixer discharge	Fabricate at least two concrete cylinders. Test for compressive strength at least once per each 500 to 1,000 CY.	ASTM C39, CT 521, AASHTO T22	Determines compressive strength.

Soils and Aggregates

Materials to be sampled or tested	Sample Size	Sampling/Testing Frequency	Typical Test Methods	Comments
Soils and Aggregates		Accept based on Certificate of Compliance except for nuclear gage field testing and associated laboratory tests.		
Soils and Aggregates	Test random locations for every 2500 SF and collect one 5-gallon bucket for source curve	One sample for every 500 to 1,000 tons of material placed and at least one sample per project.	ASTM D6938, D2922, CT 231, AASHTO T239	Determines field density and moisture using the nuclear gage.
Soils and Aggregates	Collect one 5-gallon bucket for source curve.	One sample for every 500 to 1,000 tons of material placed and at least one sample per project.	ASTM D1557	Moisture/Density curve for compaction results.

Appendix A – Acceptance Sampling and Testing Frequencies

Asphalt and Asphalt Concrete

Materials to be sampled or tested	Sample Size	Sampling/Testing Frequency	Typical Test Methods	Comments
Asphalt Binder		Accept based on Certificate of Compliance.		
Emulsified Asphalt		Accept based on Certificate of Compliance.		
Geotextile Fabric (placed under asphalt concrete)		Accept based on Certificate of Compliance.		
Asphalt Concrete	Cores (size as required by laboratory) and/or in-situ testing with nuclear gage	One sample/test per street if street is greater than 500 feet in length. If street is less than 500 feet long, no sample is required.	ASTM D1188, D1560, D1561, CT304, AASHTO T246, T247	Determines field density or air voids of compacted bituminous mixture.
Asphalt Concrete	Cores (size as required by laboratory)	One sample/test per street if street is greater than 500 feet in length. If street is less than 500 feet long, no sample is required.	CT 308A BSG of field cores, ASTM D2726, D1188, D5361	Calculate compaction based on average of all field cores.
Asphalt concrete	Approx. 30-lb. sample	One sample for every 1,000 tons of asphalt concrete.	CT 309, ASTM D1188, D1560, D1561, D5361, CT 304, AASHTO T246, T247	Determines laboratory density and relative compaction of asphalt concrete.
Asphalt concrete	Approx. 30-lb. sample	One sample for every 1,000 tons of asphalt concrete.	CT 202/382, ASTM C117, D2172 (use method B), AASHTO T164	Sieve analysis of ignited aggregate.
Asphalt concrete	Approx. 10-lb. sample	One sample for every 1,000 tons of asphalt concrete.	CT 366, ASTM D1560, D1561, AASHTO T246, T247	Determines the stability value of asphalt concrete.
Slurry Seals	One 0.5-gallon sample in a clean plastic container.	One sample per truck.	CT 125, ASTM D979, AASHTO T40, T168	Describes procedure for sampling the slurry seal.
Aggregate for Slurry Seals		Accept based on Certificate of Compliance.		
Aggregate for Chip Seals	Approx. 50-lb. sample	One sample per day for Cleaness Value. Accept of other material characteristics based on Cert of Compliance.	CT227	Determines the Cleaness Value

Appendix A – Acceptance Sampling and Testing Frequencies

Steel

Materials to be sampled or tested	Sample Size	Sampling/Testing Frequency	Typical Test Methods	Comments
Steel Strand and Rebar		Accept based on Certificate of Compliance.		