



City of Lafayette

Downtown Design Guidelines

Adopted September 8, 2014



Table of Contents

TITLE	PAGE
Introduction	3-4
Format	5
Other Plans and Regulations	6
Guidelines	7-35
1. All Districts	7-20
2. West End	21-23
3. Downtown Retail	24-27
4. Plaza	28-31
5. East End	32-35
Definitions	36
Acknowledgements and Credits	37

Introduction

PURPOSE

The City Council adopted a strategic plan for the downtown, the Downtown Specific Plan, “DSP”, which calls for the development of the Downtown Design Guidelines, “Guidelines”. The Guidelines support the Downtown Specific Plan and the General Plan, and outline the City’s design objectives for downtown development. They will be used by designers, developers, planners, hearing bodies, and the public to gain a better understanding of the community’s vision for downtown development and to evaluate the merits of a project. The purpose of the Guidelines is to maintain and enhance the City’s informal, small-town character. The Guidelines hold values of the town, which include high quality design and construction and sensitivity to character and place.

VISIONS, GOALS, AND GUIDELINES

The Downtown Design Guidelines are a set of design tools that guide downtown development. These tools promote the informal character of the downtown and encourage variety in design, height, setbacks, upper story step-backs, and spacing between buildings. The Guidelines are comprised of visions, goals, and guidelines that are organized into a downtown-wide section, and district-specific sections and their character areas. The visions describe unique characteristics for that district or area. The goals describe the desired performance that must be met for that specific topic area and are deliberately broad so that they can be achieved in a variety of ways. The guidelines describe possible design solutions to achieve the visions and goals. The guidelines are intended to provide ideas, stimulate thinking, and promote quality design. They are not empirical standards, but rather reflect how the community envisions development in the downtown, and balances the needs of the businesses, residents, and visitors. While not all guidelines can be implemented in any one design, a project must satisfy all of the applicable visions and goals.

APPLICABILITY

The Guidelines apply to any project that would alter the physical appearance of any building or site and its relationship to the street within the four downtown commercial districts of the DSP. They do not apply to the public right-of-way, which is governed by the Downtown Street Improvement Master Plan “DSIMP,” nor do they apply to Downtown Neighborhoods I, II, and III, which will be governed by separate guidelines. The goals for each topic are intentionally broad so that they can be accomplished in multiple ways. This provides flexibility and allows the guidelines to apply to any project, large or small. The hearing body will ultimately determine substantial compliance with the Guidelines based on the location, scope, and nature of the project. The guidelines serve as a tool to satisfy the goals and vision; however, not all of the guidelines can be met for a particular project.

Introduction

PROCESS

The process for downtown development starts with a dialogue between the developer and the City before the design begins. The intent behind this early interaction is for clear communication of the City's goals and community's needs as they relate to the site specific opportunities and constraints. The goal is for collaborative construction of a project, rather than drastically modifying or denying the project after an application is filed. The next step in the process is a study session, which may be required based on the extent and scope of the project. A study session is an opportunity to receive feedback from the Design Review Commission on a preliminary design before much time and resources are invested in the project.

Once a formal application is submitted, the discretionary review process begins. The hearing bodies consist of the Zoning Administrator, Design Review Commission, Planning Commission, and City Council. The Zoning Administrator acts on small-scale downtown projects, the Planning Commission acts on new downtown projects, and the Design Review Commission acts on all other downtown projects. The City Council takes final action on Planning Commission appeals and building height exceptions.



RELATIONSHIP TO OTHER PLANNING TOOLS

While the Guidelines are an essential tool for good development, they do not work alone. Together with the discretionary review process, Zoning Code, and findings, the community has the tools needed for successful downtown development.

- **Zoning Code** provides standards that all development must comply with, including use, setbacks, parking, and height.
- **Findings** are the basis for the hearing body to approve or deny a project. Findings communicate the reasoning behind the hearing body's action, present the facts and policy considerations that contributed to the action, ensure adherence to procedures and requirements, and serve as an essential element of defense if the action is challenged.
- **Discretionary Review Process** provides a forum for the evaluation of projects. Through this process, planners, hearing bodies, and the public provide input and direction to the applicant. The Guidelines and Zoning Code provide the criteria applied in the discretionary review process. The hearing body bases its decision on the required findings.

Format of The Guidelines

District
Identifies context.

Side Bar
Highlights the applicable district and section.

SECTION
ALL DISTRICTS
Building Placement
Outdoor Space
Creeks & Landscape
Parking & Circulation
Height & Scale
Building Design
Amenities
Service & Utility
WEST END
DOWNTOWN RETAIL
PLAZA
EAST END

All Districts

HEIGHT & SCALE

Goal:
Height and scale of buildings should enhance diversity in building form and relate to the character of surrounding development. Buildings on Mt. Diablo Boulevard should have a two-story scale.

Guidelines:

1. Develop variation in the building form relative to the streetscape to avoid a monotonous height and scale.
2. Design large scale buildings with elements of different sizes, changes in massing, and a variety of details, materials, and colors to avoid monolithic building form.
3. Provide upper story step-backs and varied building heights to:
 - a. provide diversity from adjacent and nearby developments
 - b. reduce the massing of the building
 - c. preserve views of surrounding hillsides and ridges
4. Step-back second or third stories with enough dimension to allow for actual uses and related amenities.
5. Mitigate height and scale using topography and backdrops, such as hillsides, freeway, trees, and existing development.



Guideline 1 and 2



Guideline 3 and 4



Guidelines 1 and 2

Page 16

City of Lafayette

Section

Indicates topics within each district.

Goal

Written statements of desired performance within each section.

Guidelines

Offer possible design solutions as ways of accomplishing the section's vision and goals.

Illustration or Photograph

These visuals are illustrative in nature, demonstrating the noted guidelines.

Standards

Identify the requirement for height, stories, and density, as stated in the Zoning Code and Downtown Specific Plan.

Map
Shows the boundaries of the district.

Vision
Describes the character of the district or area and sets forth broad directives for development.

SECTION
ALL DISTRICTS
Building Placement
Outdoor Space
Creeks & Landscape
Parking & Circulation
Height & Scale
Building Design
Amenities
Service & Utility
WEST END
DOWNTOWN RETAIL
PLAZA
EAST END

West End District

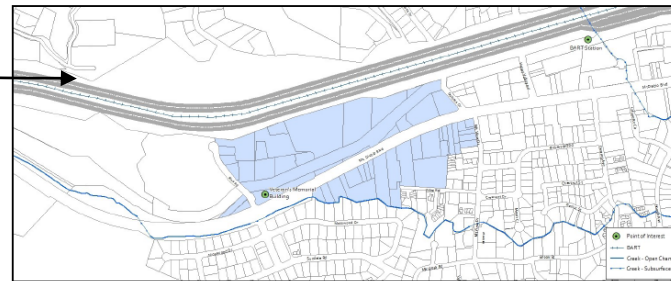

West End District Vision:

The West End district is primarily an office and commercial district, comprised of larger buildings. Development should be sited in an informal pattern with an emphasis on spacing between and around buildings and flexible parking configurations. The design intent is to maintain an open character with generous landscaped front and side setbacks. There should be an emphasis on native plants for landscaping as the area transitions from the downtown core to the more rural area to the west of the district. Safe and continuous pedestrian access is a priority as this district connects the downtown with the Lafayette Reservoir and is within walking distance to BART.

West End District Zoning Standards:

- Height: 35 ft.
- Stories: 3
- Housing Density: 35 dwelling units per acre

Other Applicable Plans and Regulations

RELATIONSHIP TO OTHER CODES AND PLANS

In addition to the Guidelines, development is informed by the General Plan, master plans and specific plans, and the Zoning Code, as described below. A project must comply with all applicable goals, policies, programs, guidelines, and standards in order to be approved.

- **General Plan** is a broad policy document that articulates the community's vision through goals, policies and programs. It is a long-range and comprehensive plan that coordinates all major components of the community's physical development. All other codes and regulations must be consistent with the General Plan.
- **Master Plans & Specific Plans** build on the General Plan to provide a more detailed framework to guide development based on a specified area and/or on specific topics. These plans are implemented through goals, policies, and programs.
- **Zoning Code** is the implementation tool that translates General Plan policies and programs into action by dividing the City into zoning districts and applying different development standards, including use, setbacks, parking, and height. The Zoning Code also outlines criteria, such as process and the required findings, that are applicable for a particular project.

GENERAL PLAN

- [General Plan](#)

MASTER PLANS & SPECIFIC PLANS

- [Bikeways Master Plan](#)
- [Downtown Specific Plan](#)
- [Downtown Street Improvement Master Plan](#)
- [Environmental Strategy](#)
- [Parks and Recreational Facilities Master Plan](#)
- [Public Art Master Plan](#)
- [Trails Master Plan](#)
- [Trees for Lafayette](#)
- [Walkways Master Plans](#)

GUIDELINES

- [Plaza Way Overlay Design Guidelines](#)

MUNICIPAL CODE / ZONING CODE

- [Creek Setback Regulations](#)
- [Demolition in the Downtown](#)
- [Historic Landmarks](#)
- [Plaza Way Overlay](#)
- [Public Art Regulations](#)
- [Sign Regulations](#)
- [Stormwater Pollution Prevention Regulations](#)
- [Tree Protection Regulations](#)
- [Zoning District Development Standards](#)

FEDERAL, STATE, AND REGIONAL STANDARDS

- [California Building Code](#)
- [California Environmental Quality Act \(CEQA\)](#)
- [California Water Efficient Landscape Ordinance](#)
- [Contra Costa County Flood Control District 50 Year Plan](#)
- [National Pollutant Discharge Elimination System](#)
- [Standards for the Treatment of Historic Properties](#)
- [Stormwater C.3 Guidebook](#)

Section 1: All Districts

SECTION

All Districts

ALL DISTRICTS

Building Placement

Outdoor Space

Creeks & Landscape

Parking & Circulation

Height & Scale

Building Design

Amenities

Service & Utility

WEST END

DOWNTOWN RETAIL

PLAZA

EAST END

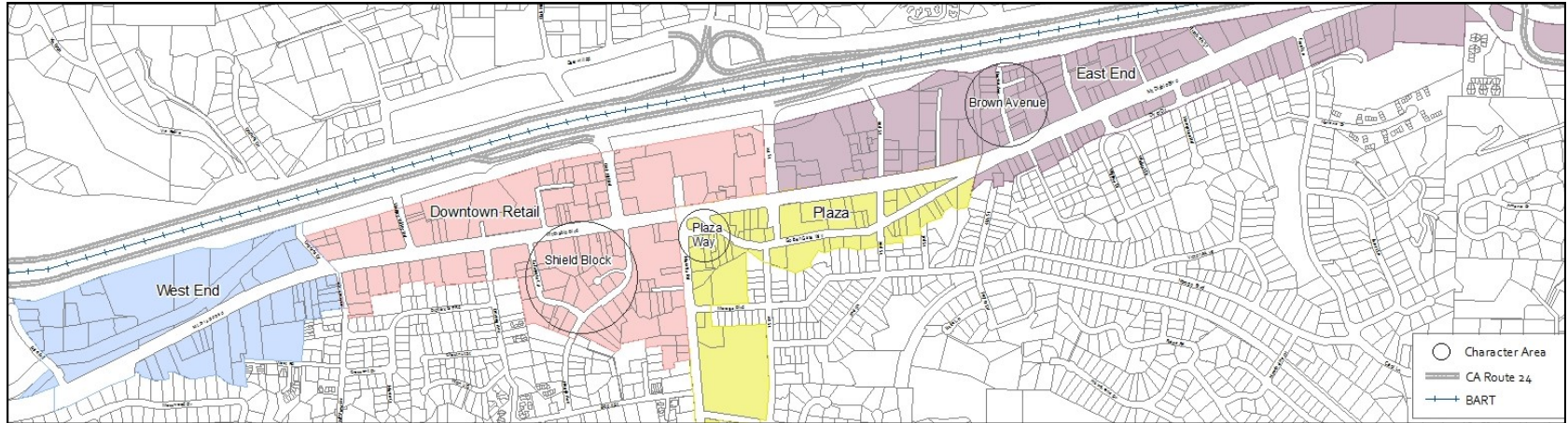

Downtown Vision – All Districts:

Lafayette has a linear downtown organized around Mt. Diablo Boulevard. The downtown is characterized by its small-town environment within a unique natural setting, including physical and visual access to creeks, hillsides, and ridgelines. The downtown character is informal with variations in architectural designs, building heights, setbacks, and spacing of buildings. The downtown provides a sense of place where the community can congregate, shop, dine, and enjoy cultural activities. Development should respond to the site’s unique characteristics with custom design that weaves into the fabric of the downtown. It should also enhance the pedestrian experience and provide internal connections to improve the existing circulation network. Opportunities for public benefit and sustainable practices should be explored for each project.

The downtown is comprised of four downtown commercial districts, some of which contain character areas. Each district has unique qualities which defines its character. As such, specific guidelines are provided in the district and character areas that build on these qualities. Guidelines within the All Districts section apply to all projects; whereas district specific guidelines apply to development located within that district. In transitional areas, the hearing bodies may apply guidelines from neighboring districts as well.

- **West End** district is semi-rural in nature and represents the transition from the open hills to the downtown. Uses are largely offices and residential.
- **Downtown Retail** district is the pedestrian oriented center of the city with retail and shopping as the focal uses. The Shield Block Character Area, in the Downtown Retail District, is defined by a wooded setting with large established trees and a creek as a central feature.
- **Plaza** district is the cultural and civic focus of the community, fostering a hub of activities. The Plaza Way Character Area, in the Plaza District, is the historic center with uses that embrace the Lafayette Plaza.
- **East End** district provides a mix of uses with an emphasis on auto-services. The Brown Avenue Character Area, in the East End District, is a mixed use area with a residential character.

All Districts

BUILDING PLACEMENT

Goal:

Building placement should be varied to create visual interest, allow views, complement the natural environment, and enhance Lafayette’s informal and distinctive character.

Guidelines:

1. Provide varied position and spacing between buildings to:
 - a. enhance Lafayette’s informal character
 - b. enable diversity in look and feel
 - c. provide articulation in the building frontage
 - d. allow views of hillsides, ridges, and creek corridors
 - e. provide visual relief and openness
2. Locate buildings to provide a semi-public space to expand and promote use of the public realm.
3. Design corner lots by ensuring that the corner has an active use to draw the public into the block.
4. Locate buildings to enhance natural day lighting.



Guideline 1



Guideline 1



Guidelines 2 and 3

SECTION

ALL DISTRICTS

Building Placement

Outdoor Space

Creeks & Landscape

Parking & Circulation

Height & Scale

Building Design

Amenities

Service & Utility

WEST END

DOWNTOWN RETAIL

PLAZA

EAST END

SECTION

All Districts

ALL DISTRICTS

OUTDOOR SPACE

Goal:

Outdoor space should foster social interaction and embrace natural features to enhance Lafayette’s small-town character.

Guidelines:

1. Activate and expand the public realm by linking outdoor spaces to existing assets such as courtyards, creeks, established trees, sidewalks, and the aqueduct path.
2. Incorporate upper story decks, balconies, and rooftop gardens to add vitality and eyes on the street.
3. Locate and design outdoor space to minimize noise and privacy impacts when adjacent to residential uses.
4. Reduce the impacts of paving by limiting its use, using permeable surfaces, and treating and filtering runoff.
5. Incorporate outdoor space with amenities for public use, such as pocket parks, play structures, and water features.

Building Placement

Outdoor Space

Creeks & Landscape

Parking & Circulation

Height & Scale

Building Design

Amenities

Service & Utility

WEST END

DOWNTOWN RETAIL

PLAZA

EAST END



Guideline 1



Guideline 1

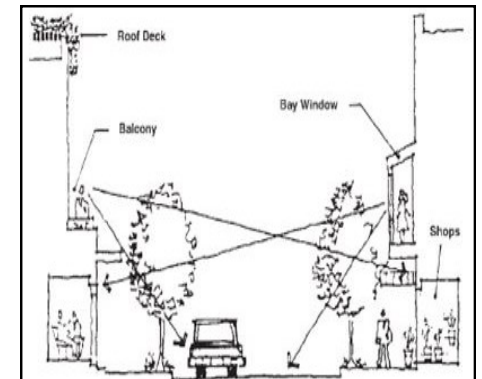

Guideline 2

All Districts

SECTION

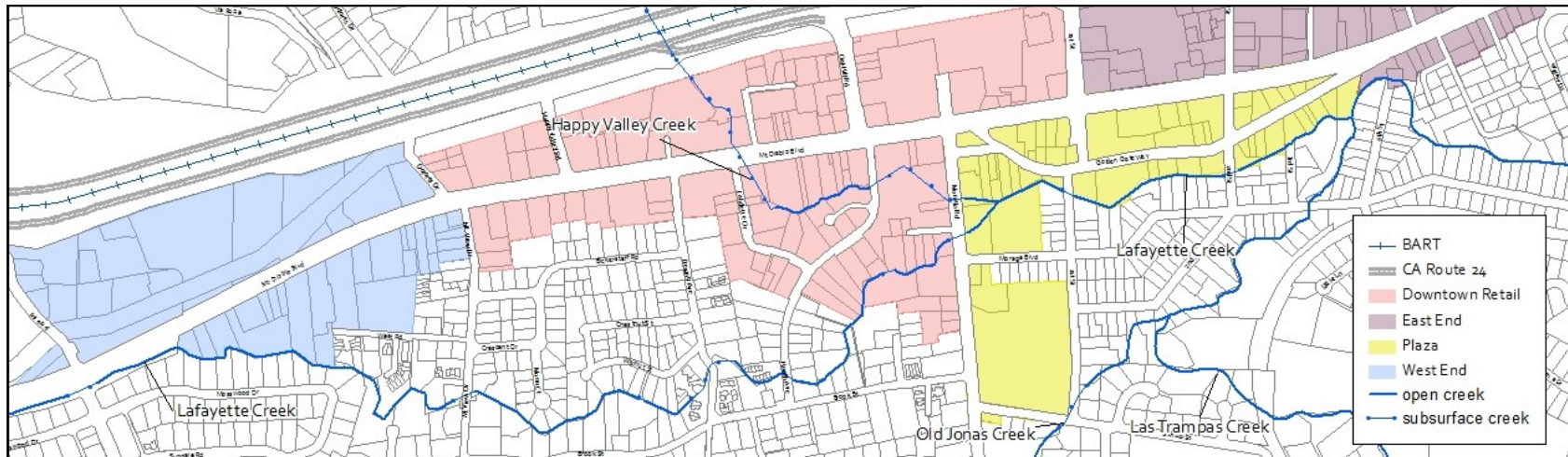

ALL DISTRICTS

Building Placement

Outdoor Space

Creeks & Landscape

Parking & Circulation

Height & Scale

Building Design

Amenities

Service & Utility

WEST END

DOWNTOWN RETAIL

PLAZA

EAST END

CREEKS & LANDSCAPE

Creeks

Goal:

Development design should embrace creeks and connect the public to them.

Guidelines:

1. Maintain and restore native riparian areas.
2. Provide views of the creek through window placement, decks, balconies, and outdoor spaces.
3. Orient development to take advantage of the creek for walkways, dining, and outdoor space.
4. Maintain an open character by deemphasizing property lines and reinforcing the continuity of the creek.
5. Transition landscaping toward and along the creek corridor for a consistent native riparian plant palette.
6. Provide public creek crossings to link neighborhoods to the downtown.

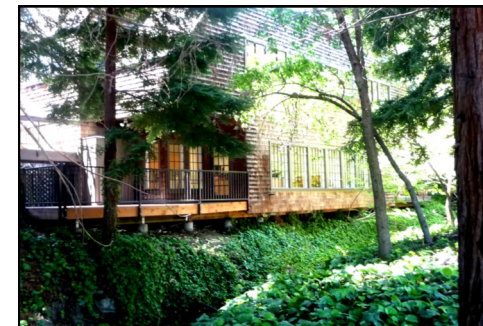

Guideline 2



Guideline 3

SECTION

All Districts

ALL DISTRICTS

CREEKS & LANDSCAPE (CONTINUED)

Landscape

Goal:

Landscaping should enhance the aesthetic quality and design of the downtown, create an inviting environment for pedestrians, and mitigate impacts related to noise, privacy, and environmental quality.

Guidelines:

7. Preserve downtown trees by designing development around existing trees and minimizing encroachment within the dripline of the trees.
8. Integrate plantings into development to:
 - a. provide screening and establish a buffer, particularly when adjacent to residential properties
 - b. enhance the pedestrian experience
 - c. visually break-up large paved areas
 - d. soften the built environment
 - e. mitigate freeway impacts
 - f. reinforce the visual identity of the districts and streets
9. Incorporate drainage features as part of the landscape design.
10. Minimize water usage by using drought tolerant plants and designing irrigation systems with hydrozones and moisture sensors.

Building Placement

Outdoor Space

Creeks & Landscape

Parking & Circulation

Height & Scale

Building Design

Amenities

Service & Utility

WEST END

DOWNTOWN RETAIL

PLAZA

EAST END



Guidelines 7 and 8



Guideline 8



Guideline 9

All Districts

PARKING & CIRCULATION

Motorized Vehicles

Goal:

Parking and circulation should provide a continuous flow of motorized vehicles, enhancing safety, and maintaining the pedestrian and bicycling experience.

Guidelines:

1. Improve parking facility efficiency through structured parking, lifts, and shared parking.
2. Limit interruptions and maximize on-street parking by:
 - a. minimizing the number of curb cuts through shared driveways with adjacent properties
 - b. reducing the width of curb cuts to the minimum needed for safe ingress and egress
 - c. locating driveways away from street corners and on secondary streets instead of primary streets
 - d. connecting and sharing parking lots
3. Design parking lots to avoid dead-end parking aisles and vehicles backing onto streets, pedestrian paths of travel, or main drive aisles.
4. Provide access driveways to allow smooth flow of vehicles entering and exiting the parking lot and minimize conflicts with vehicles and bicycles.
5. Incorporate dedicated passenger pick-up & drop-off points near building entries and outside the path of travel for an uninterrupted vehicular circulation.
6. Locate truck loading facilities on-site with access from secondary streets to minimize noise and traffic impacts to encourage consolidation of freight deliveries to increase efficiency and reduce congestion.
7. Incorporate lighting, surveillance, sight lines, or other measures to enhance personal safety.
8. Incorporate charging stations and other incentives to encourage the use of alternative fuel and low emission vehicles.
9. Reduce the impacts of paving by using permeable surfaces and treating and filtering runoff.
10. Design parking structures to relate to the development's architecture.

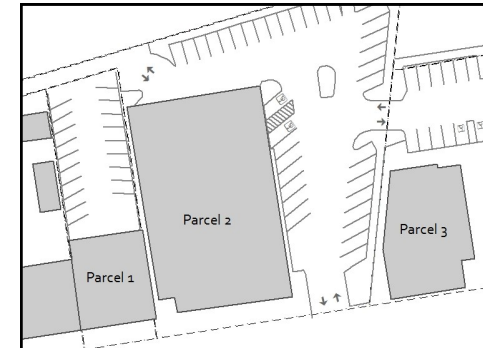

Guideline 2

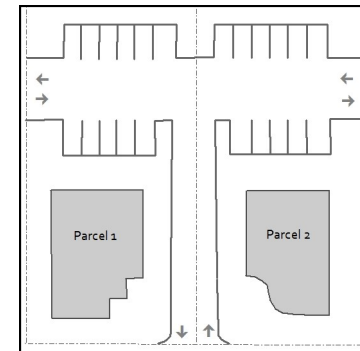

Guideline 2 and 4

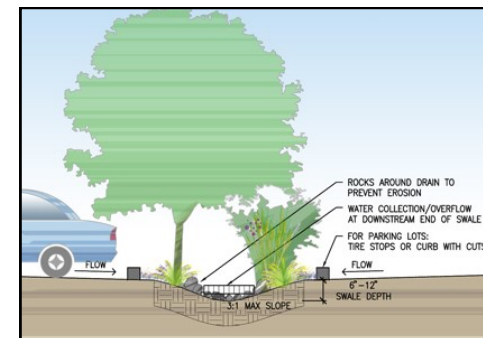

Guideline 9

SECTION

ALL DISTRICTS

Building Placement

Outdoor Space

Creeks & Landscape

Parking & Circulation

Height & Scale

Building Design

Amenities

Service & Utility

WEST END

DOWNTOWN RETAIL

PLAZA

EAST END

SECTION

All Districts

ALL DISTRICTS

PARKING & CIRCULATION (CONTINUED)

Bicycles

Goal:

Bicycle parking & circulation should be easily accessible, convenient, safe, and visible to encourage bicycling in the downtown.

Guidelines:

- 11. Provide bicycle parking in well illuminated, secured, covered, and convenient areas. Short-term bicycle parking should be visible from building entrances.
- 12. Close gaps and develop links to the existing and planned bicycle network.
- 13. Provide on-site facilities, such as employee lockers, changing rooms, and showers.
- 14. Improve awareness and safety of bicycle circulation through concepts like signage, colored pavement, striping, rear-in angled parking, and traffic calming measures.



Guideline 11

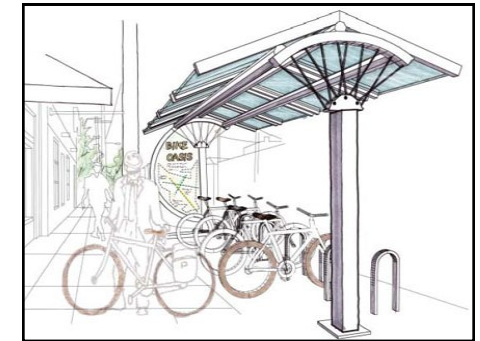

Guideline 11

Building Placement

Outdoor Space

Creeks & Landscape

Parking & Circulation

Height & Scale

Building Design

Amenities

Service & Utility

WEST END

DOWNTOWN RETAIL

PLAZA

EAST END

All Districts

PARKING & CIRCULATION (CONTINUED)

Pedestrians

Goal:

Pedestrian circulation should be easily accessible, direct, safe, and aesthetically pleasing to encourage walking in the downtown.

Guidelines

15. Integrate Americans with Disabilities Act, "ADA", improvements seamlessly into the project design.
16. Design walkways to allow unobstructed pedestrian circulation with dimension for added amenities.
17. Provide direct walkways which discourage shortcuts.
18. Incorporate dedicated pedestrian paths of travel between:
 - a. buildings
 - b. parked vehicles and building entries
 - c. the street and the building
19. Close gaps and develop links to natural features and the existing and planned pedestrian network through paths, trails, and walkways.
20. Create or improve pedestrian connections between neighborhoods and the downtown.
21. Improve pedestrian access to public services and transportation by providing connections, enhancing crosswalks, and installing way finding signage.
22. Provide low screening at parking lot edges adjacent to public streets for visual relief, and separation for pedestrians.
23. Improve safety where pedestrian and vehicle routes cross through:
 - a. reduced width and quantity of driveways
 - b. shortened crossing distance, such as curb extensions or bulb-outs
 - c. minimized width of drive aisles
 - d. reversed diagonal parking spaces
 - e. specialized pavement materials, such as textured or colored paving
 - f. enhanced striping and signage
 - g. improved lighting
 - h. increased visibility and sight distance



Guidelines 18 and 20



Guideline 22



Guideline 23

SECTION

ALL DISTRICTS

Building Placement

Outdoor Space

Creeks & Landscape

Parking & Circulation

Height & Scale

Building Design

Amenities

Service & Utility

WEST END

DOWNTOWN RETAIL

PLAZA

EAST END

SECTION

All Districts

ALL DISTRICTS

HEIGHT & SCALE

Goal:

Height and scale of buildings should enhance diversity in building form and relate to the character of surrounding development. Buildings on Mt. Diablo Boulevard should have a two-story scale.

Guidelines:

1. Develop variation in the building form relative to the streetscape to avoid a monotonous height and scale.
2. Design large scale buildings with elements of different sizes, changes in massing, and a variety of details, materials, and colors to avoid monolithic building form.
3. Provide upper story step-backs and varied building heights to:
 - a. provide diversity from adjacent and nearby developments
 - b. reduce the massing of the building
 - c. preserve views of surrounding hillsides and ridges
4. Step-back second or third stories with enough dimension to allow for actual uses and related amenities.
5. Mitigate height and scale using topography and backdrops, such as hillsides, freeway, trees, and existing development.



Guideline 1 and 2

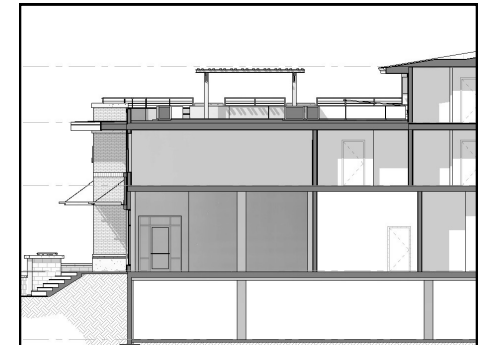

Guideline 3 and 4

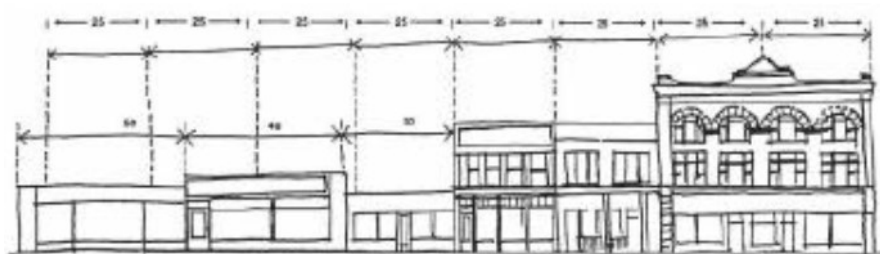

Guidelines 1 and 2

Building Placement

Outdoor Space

Creeks & Landscape

Parking & Circulation

Height & Scale

Building Design

Amenities

Service & Utility

WEST END

DOWNTOWN RETAIL

PLAZA

EAST END

All Districts

BUILDING DESIGN

Goal:

Building design should complement the diverse, informal small-town character.

Guidelines:

1. Design buildings to be adaptable to multiple uses and occupants for extended life-cycles.
2. Design additions that integrate well into the building design.
3. Maximize ground floor transparency to allow views of the use and activity within the building.
4. Clearly identify the primary entrance to a building.
5. Incorporate upper-story elements to create view opportunities to the street, such as windows, balconies, and terraces.
6. Design corner buildings to serve as an anchor to development with architectural features, such as taller elements, chamfered edges, and detailing.
7. Incorporate details and elements that complement the architectural style and bolster the overall character of the development.
8. Use an appropriate range of colors and durable materials in a direct and authentic manner.
9. Use materials to create a casual but distinctive quality and diverse palette relative to the downtown.
10. Avoid building design which uses a formulaic corporate theme in form or coloration.
11. Incorporate energy collectors into the building design to appear visually unobtrusive.
12. Design projects with a competent and coherent architectural style.
13. Provide frontages that open up at the ground level for more transparency and interaction between public and private space.
14. Design buildings with entrances and display windows facing the interior of the block, as well as the street, to foster interior pedestrian flow.

Before



Guideline 6

After



Guideline 3



Guideline 7



Guideline 8

SECTION

ALL DISTRICTS

Building Placement

Outdoor Space

Creeks & Landscape

Parking & Circulation

Height & Scale

Building Design

Amenities

Service & Utility

WEST END

DOWNTOWN RETAIL

PLAZA

EAST END

SECTION

All Districts

ALL DISTRICTS

AMENITIES

Lighting

Goal:

Lighting should enhance safety, provide ambiance, and create a lively environment for pedestrians.

Guidelines:

1. Choose light fixtures that are in scale with and complement the architecture of the building.
2. Locate fixtures so that illumination is not obstructed by landscaping or structures.
3. Design lighting so that the orientation and intensity of illumination will not produce a glare or otherwise adversely affect nearby users.
4. Reduce lighting to minimize light pollution and energy consumption, while providing adequate illumination for safety.

Signage

Goal:

Signage should exhibit quality materials and variety that reflects the small-town character of Lafayette.

Guidelines:

5. Design signs with external illumination that complements the architectural character of the building or setting.
6. Prepare a master sign plan for all multi-tenant buildings and shopping centers to establish locations, dimensions, colors, materials, and illumination.
7. Coordinate signage and landscape elements to ensure appropriate visibility.
8. Provide pedestrian-oriented signage in areas of high pedestrian activity.
9. Scale signage appropriately so that it does not overpower its setting.
10. Design creative and unique signage which complements the building architecture.



Guideline 1



Guidelines 5, 8, and 9

Building Placement

Outdoor Space

Creeks & Landscape

Parking & Circulation

Height & Scale

Building Design

Amenities

Service & Utility

WEST END

DOWNTOWN RETAIL

PLAZA

EAST END

All Districts

AMENITIES (CONTINUED)

Public Art

Goal:

Public art should contribute to the cultural experience and unique character of the community.

Guidelines:

11. Design public art to relate to its setting, be site specific, and be integral to the project.
12. Provide public art in visible and accessible locations to enhance ambiance and encourage congregation.

Furnishings

Goal:

Furnishings should provide comfort, perform a function, and enhance the downtown vitality.

Guidelines:

13. Provide furnishings, including trash and recycling receptacles, that complement the design and use of the building.
14. Consider furnishings as artistic elements to enhance the development’s design concept.
15. Provide amenities that serve a range of users.



Guidelines 11 and 12



Guideline 11 and 12



Guidelines 13, and 14

SECTION

ALL DISTRICTS

Building Placement

Outdoor Space

Creeks & Landscape

Parking & Circulation

Height & Scale

Building Design

Amenities

Service & Utility

WEST END

DOWNTOWN RETAIL

PLAZA

EAST END

SECTION

All Districts

ALL DISTRICTS

SERVICE & UTILITY

Goal:

Service and utility areas should be sited and designed to minimize visual and physical impacts.

Guidelines:

1. Locate service and utility areas internal to the building or underground. Otherwise, screen them from public view.
2. Incorporate architectural styles, colors and other elements from the building design to adequately screen service and utility areas.
3. Locate service and utility areas:
 - a. in a convenient and safe area,
 - b. to minimize conflicts and nuisances with other on-site and off-site uses, and
 - c. away from primary streets.
4. Cluster and consolidate service areas of adjacent businesses and properties together.

Building Placement

Outdoor Space

Creeks & Landscape

Parking & Circulation

Height & Scale

Building Design

Amenities

Service & Utility

WEST END

DOWNTOWN RETAIL

PLAZA

EAST END

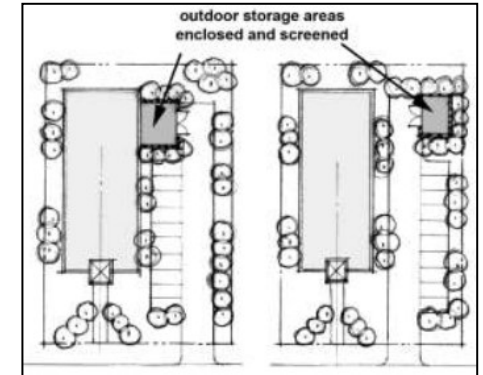

Guideline 1

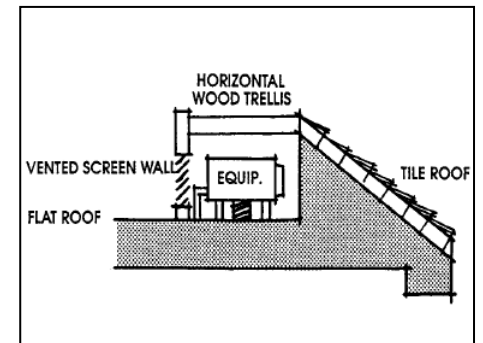

Guideline 1



Guideline 2

Section 2: West End District

SECTION

West End District

ALL DISTRICTS

Building Placement

Outdoor Space

Creeks & Landscape

Parking & Circulation

Height & Scale

Building Design

Amenities

Service & Utility

WEST END

DOWNTOWN RETAIL

PLAZA

EAST END

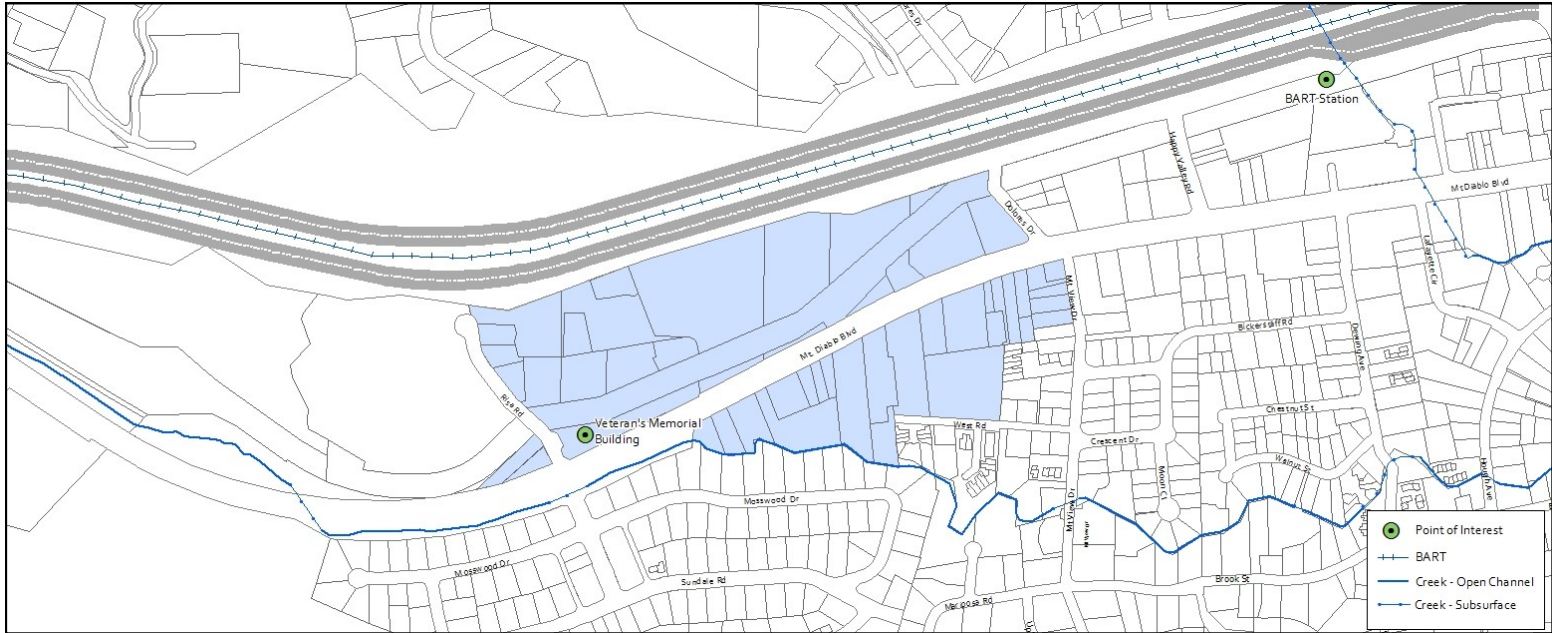

West End District Vision:

The West End district is primarily an office and commercial district, comprised of larger buildings. Development should be sited in an informal pattern with an emphasis on spacing between and around buildings and flexible parking configurations. The design intent is to maintain an open character with generous landscaped front and side setbacks. There should be an emphasis on native plants for landscaping as the area transitions from the downtown core to the more rural area to the west of the district. Safe and continuous pedestrian access is a priority as this district connects the downtown with the Lafayette Reservoir and is within walking distance to BART.

West End District Zoning Standards:

- Height: 35 ft.
- Stories: 3
- Housing Density: 35 dwelling units per acre

West End District

West End District Guidelines:

OUTDOOR SPACE

1. Incorporate outdoor space for use within complexes. When outdoor space is part of the public realm, it should relate to the natural environment.

CREEKS & LANDSCAPE

2. Emphasize use of native plants in a natural and informal manner to reflect the transition between the downtown core and the more rural area to the west of the district.
3. Provide generous landscaped areas in front of and between buildings so that the landscape reads as the connecting aspect of the district.

PARKING & CIRCULATION

4. Screen vehicular parking from public vantage points with native plants.
5. Provide informal walkways with recognizable separation of pedestrians and vehicles.

HEIGHT & SCALE

6. Use increased setbacks, spacing between buildings, topography, and substantial landscaping to allow buildings to appear two-story in scale.

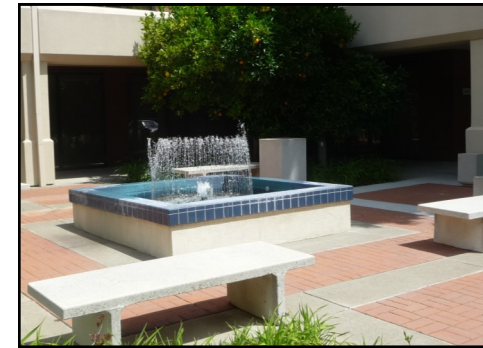

Guideline 1



Guidelines 2 and 3



Guideline 6

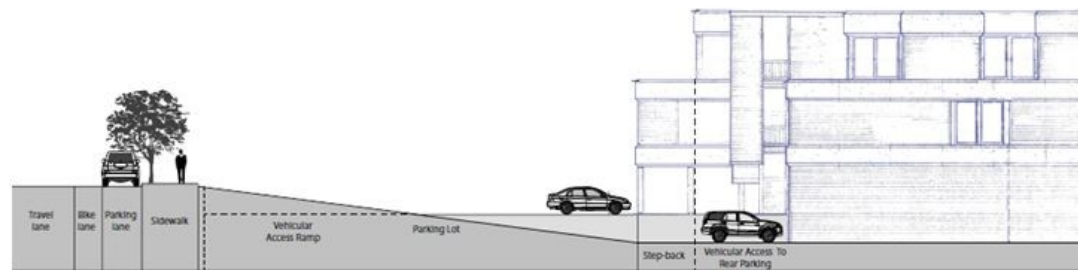

Guideline 6

SECTION

ALL DISTRICTS

Building Placement

Outdoor Space

Creeks & Landscape

Parking & Circulation

Height & Scale

Building Design

Amenities

Service & Utility

WEST END

DOWNTOWN RETAIL

PLAZA

EAST END

Section 3: Downtown Retail District

Downtown Retail District

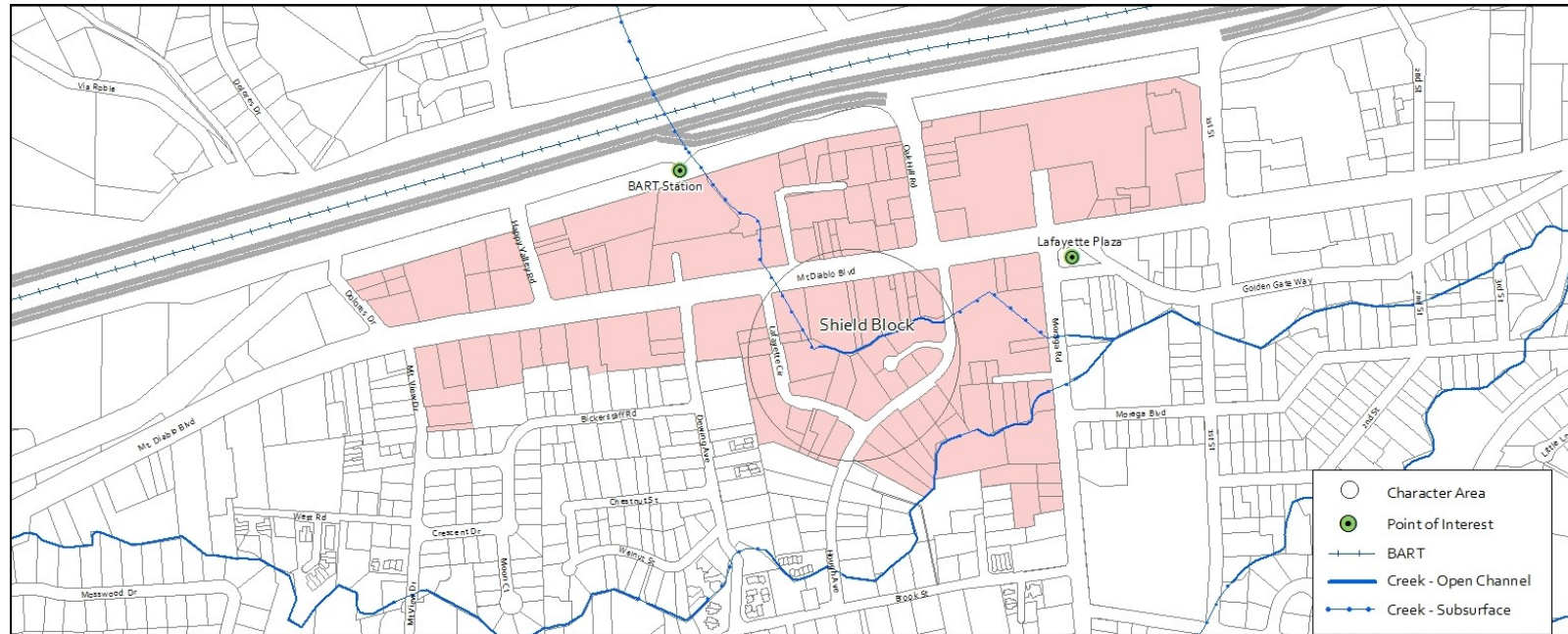

Downtown Retail District Vision:

The Downtown Retail district is the “heart” of the downtown with a pedestrian ambiance and an active set of uses. Buildings should be sited close to the sidewalk and close together, making a tightly knit downtown fabric. Parking should be integrated into or behind buildings to maximize an active retail frontage. Buildings should cluster around plazas, courtyards, connecting corridors, seating, and outdoor dining areas.

This district supports a high volume of pedestrian activity. Ground floor uses should maintain a human scale, attracting pedestrians through window displays and signage. Uses should spill into the sidewalk blurring the edge between the public and private realm to provide an attractive and vibrant downtown with public amenities. The design intent is to maintain the ambiance of a small-town with people strolling, shopping, dining, gathering, working, and living in an interesting, vital, and lively environment. This district, along with the Plaza district, make up the core of the downtown

Downtown Retail District Zoning Standards:

- Height: 35 ft.
- Stories: 3
- Housing Density: 35 dwelling units per acre

SECTION

ALL DISTRICTS

Building Placement

Outdoor Space

Creeks & Landscape

Parking & Circulation

Height & Scale

Building Design

Amenities

Service & Utility

WEST END

DOWNTOWN RETAIL

PLAZA

EAST END

SECTION	Downtown Retail District
ALL DISTRICTS	<p>Downtown Retail District Guidelines:</p> <p><u>BUILDING PLACEMENT</u></p> <ol style="list-style-type: none"> 1. Locate buildings close to the sidewalk and close together, establishing a continuum of frontages. 2. Provide variations in building placement along street edges to provide a less formal appearance, create visual interest, and allow for articulation. <p><u>OUTDOOR SPACE</u></p> <ol style="list-style-type: none"> 3. Design spaces in front of and between buildings to promote active uses and to create a variety of complementarity environments. 4. Allow transparency through outdoor space enclosures, when provided, to enliven the area. <p><u>CREEKS & LANDSCAPE</u></p> <ol style="list-style-type: none"> 5. Integrate landscape elements into the built environment to accommodate for high pedestrian activity. 6. Provide pathway connections and footbridge crossings at intervals along the Happy Valley and Lafayette creeks to improve access with the neighborhoods. <p><u>PARKING & CIRCULATION</u></p> <ol style="list-style-type: none"> 7. Integrate parking into or behind buildings to provide storefront continuity and maximize the pedestrian experience. 8. Pursue opportunities for shared parking and improved access to increase use of existing parking. <p><u>HEIGHT & SCALE</u></p> <ol style="list-style-type: none"> 9. Provide a rhythm of narrow storefront bays for a human-scaled environment and to reduce the apparent building scale. 10. Visually step-back or setback taller development from Mt. Diablo Boulevard while still maintaining a building presence close to the sidewalk.
Building Placement	
Outdoor Space	
Creeks & Landscape	
Parking & Circulation	
Height & Scale	
Building Design	
Amenities	
Service & Utility	
WEST END	
DOWNTOWN RETAIL	
PLAZA	
EAST END	



Guideline 1 and 9



Guideline 4 and 5

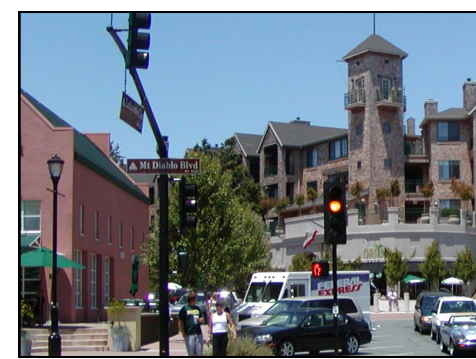

Guideline 10

Shield Block Character Area

Shield Block Character Area Vision:

The Shield Block, as further described in the [Downtown Specific Plan](#) (DSP), is defined by a wooded setting, with large trees and the creek as the central core. This block is developed with low scale, older buildings, with retail and parking internal to the block, and meandering pedestrian passageways. Building placement should be loose and allow physical and visual access through properties. Emphasis should be placed on providing creekside walkways, passageways, creek crossings, and outdoor dining areas to enhance the natural setting. The design intent is to create an attractive area to entice people to shop, dine, and stroll. To further this concept, the DSP envisions a passive park adjacent to the creek (the Town Green), as a place for the public to gather, relax, and enjoy community events.

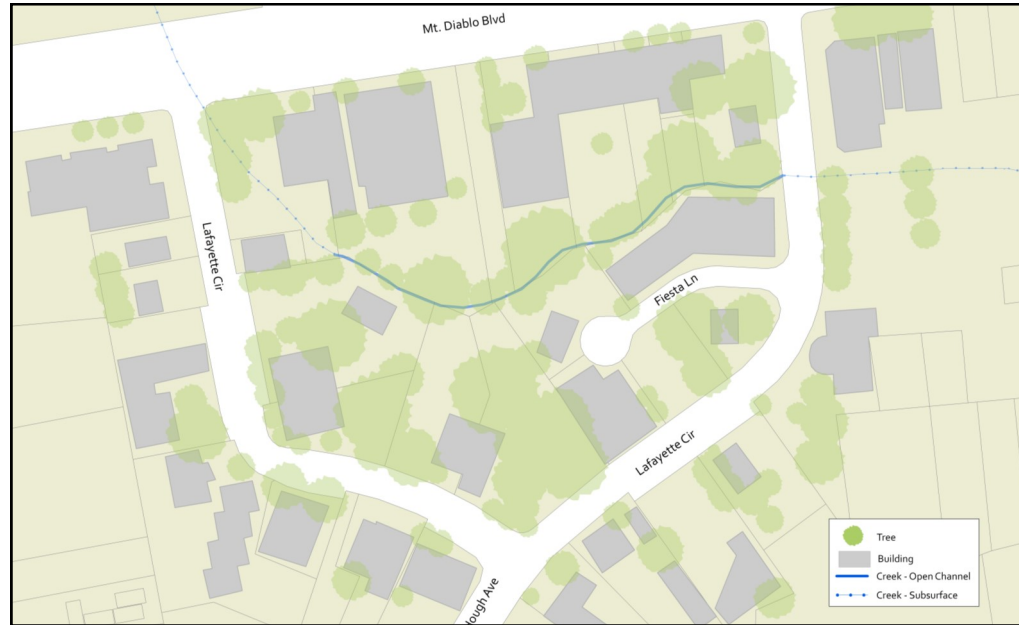

Shield Block Character Area Zoning Standards:

- Height: 35 ft.
- Stories: 3
- Housing Density: 35 dwelling units per acre

Shield Block Character Area Guidelines:

1. Provide low scale buildings sited close to the sidewalk to maintain the village scale.
2. Use natural materials to maintain the village character of the area, which includes wood and brick-clad buildings.
3. Provide shared parking, improved access, and connections between lots to increase use of existing parking, expand the pedestrian network, and maintain visual and physical access.
4. Retain the creek side setting and preserve the existing trees to reinforce the visual identity of the area.



Guidelines 1 and 2



Guideline 2

SECTION

ALL DISTRICTS

Building Placement

Outdoor Space

Creeks & Landscape

Parking & Circulation

Height & Scale

Building Design

Amenities

Service & Utility

WEST END

DOWNTOWN RETAIL

PLAZA

EAST END

Section 4: Plaza District

Plaza District

SECTION

ALL DISTRICTS

Building Placement

Outdoor Space

Creeks & Landscape

Parking & Circulation

Height & Scale

Building Design

Amenities

Service & Utility

WEST END

DOWNTOWN RETAIL

PLAZA

EAST END

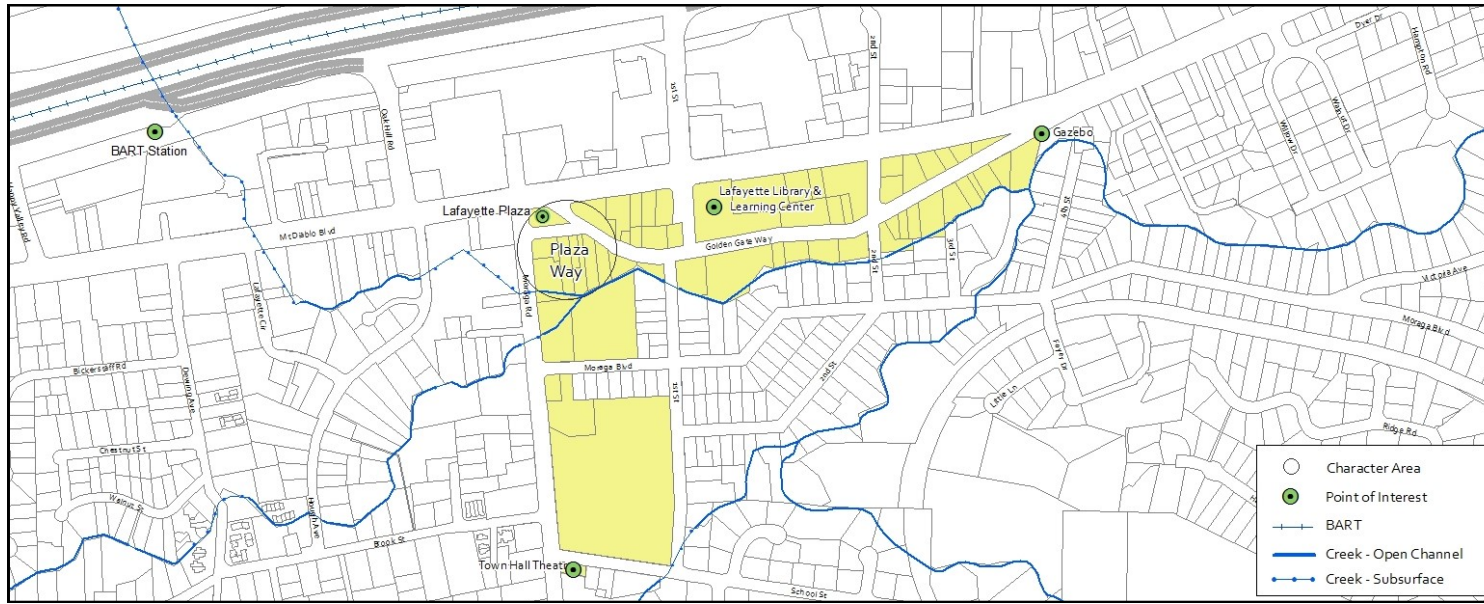

Plaza District Vision:

The Plaza district is the civic and cultural hub of the downtown with community activities revolving around Lafayette Plaza. A critical component of this district is uses that take advantage of these activities. Outdoor space should reinforce this district as the central community gathering space and take advantage of the proximity to the creek. Development should draw on the Lafayette Library and Learning Center as a cultural and educational asset and create a synergy of complementary uses. The [Downtown Specific Plan \(DSP\)](#) expanded on this concept by envisioning an active park southwest of the Library to complement the surrounding uses. This district, along with the Downtown Retail district, make up the core of the downtown.

The Plaza district, which is bordered by the Lafayette Creek, is defined by four distinct streets: Mt. Diablo Boulevard, Moraga Road, Plaza Way, and Golden Gate Way. Development along the south side of Mt. Diablo Boulevard should serve as the transition between the retail-based Downtown Retail district and the commercial-based East End district. Development along Moraga Road should be less concentrated with greater setbacks and a residential character to transition between the core of the downtown and the neighborhoods to the south. Development along Plaza Way and Golden Gate Way should be sited close to the sidewalk and close together, with parking behind buildings or underground to create a pedestrian-friendly environment and maximize an active retail frontage. Traffic on Golden Gate Way is slower paced, creating a more relaxed setting than the other streets.

Plaza District Zoning Standards (except for Plaza Way Character Area):

- Height: 35 ft.
- Stories: 3
- Housing Density: 35 dwelling units per acre

SECTION	Plaza District
ALL DISTRICTS	<p>Plaza District Guidelines:</p> <p><u>BUILDING PLACEMENT</u></p> <ol style="list-style-type: none"> 1. Locate buildings close to the sidewalk and close together, establishing a continuum of frontages. 2. Provide variations in building placement along street edges to provide articulation, an informal appearance, and visual interest. <p><u>OUTDOOR SPACE</u></p> <ol style="list-style-type: none"> 3. Connect outdoor spaces to expand the public realm, creating a community living room. 4. Provide adequate space for dining fronting the street or creek to create a vibrant pedestrian environment. <p><u>CREEKS & LANDSCAPE</u></p> <ol style="list-style-type: none"> 5. Integrate landscape elements to accommodate high pedestrian activity. 6. Enhance creek access. <p><u>PARKING & CIRCULATION</u></p> <ol style="list-style-type: none"> 7. Pursue opportunities for shared and connected parking to improve parking utilization to accommodate a variety of uses, events, and activities. 8. Integrate parking into or behind buildings to provide storefront continuity and maximize the pedestrian experience. 9. Develop connections to, along, and across Lafayette Creek to the extent feasible. <p><u>HEIGHT & SCALE</u></p> <ol style="list-style-type: none"> 10. Provide a rhythm of narrow storefront bays for a human-scaled environment and to reduce the apparent building scale.
Building Placement	
Outdoor Space	
Creeks & Landscape	
Parking & Circulation	
Height & Scale	
Building Design	
Amenities	
Service & Utility	
WEST END	
DOWNTOWN RETAIL	
PLAZA	
EAST END	



Guideline 1



Guideline 2



Guidelines 3 and 5

Plaza Way Character Area



Plaza Way Character Area Vision:

Plaza Way, as further described in the [Downtown Specific Plan \(DSP\)](#), is the community's historic center. The design intent is to preserve and enhance the historic village character of the area which begins on Plaza Way and extends down Golden Gate Way. These narrow, slow-paced streets promote walking, bicycling and a relaxed pedestrian-friendly environment. Development should complement the historical buildings and take advantage of its relationship to the plaza and the creek. Buildings should be sited close to the sidewalk with variations in building height to create a vibrant pedestrian environment. In addition to the guidelines below, development in this character area must also comply with the [Plaza Way Overlay Design Guidelines](#).

Plaza Way Character Area Zoning Standards:

- Height: 35 ft.
- Stories: 2
- Housing Density: 35 dwelling units per acre

Plaza Way Character Area Guidelines:

1. Design facades in a rhythmic pattern along the sidewalk to maintain continuity and relate to the existing context.
2. Provide authentic architectural detailing and decorative elements relating to the historic use of the buildings or surrounding development.
3. Limit materials and colors to simple patterns and applications to reclaim the historic development's simplicity.
4. Orient development toward the Lafayette Plaza to foster interaction with the public space.



Guideline 2 and 3



Guideline 4

SECTION

ALL DISTRICTS

Building Placement

Outdoor Space

Creeks & Landscape

Parking & Circulation

Height & Scale

Building Design

Amenities

Service & Utility

WEST END

DOWNTOWN RETAIL

PLAZA

EAST END

Section 5: East End District

East End District

SECTION

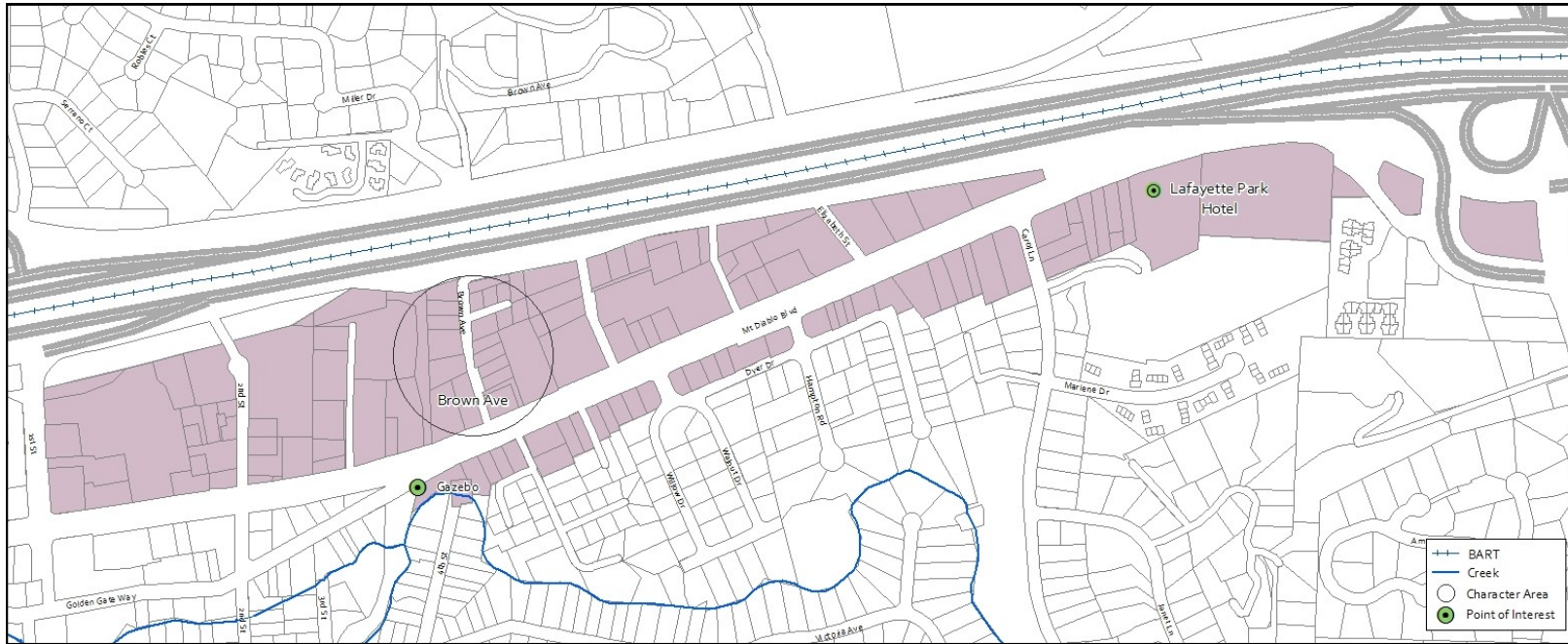

East End District Vision:

The East End district is primarily a commercial and auto-service district offering a variety of uses. The informal arrangement of buildings and variety in design is encouraged to avoid the district from developing into a strip commercial zone. Buildings can be singular in their context and designed to accommodate functional uses. The location and configuration of parking and loading facilities are flexible and can be provided in a variety of locations. Safe and continuous pedestrian access is a priority and should balance the needs of vehicles and pedestrians. Trees and landscape help to enhance the district's character and to mitigate the freeway. The area near the Lafayette Park Hotel is an opportunity for retail and restaurant uses to support visitor services. In addition, the [Downtown Specific Plan](#) (DSP) envisions a passive park adjacent to the Gazebo to serve as an amenity to the surrounding uses, including senior housing, regional trails, the bicycle network, and the creek.

East End District Zoning Standards (except Brown Avenue Character Area):

- Height: 35 ft.
- Stories: 3
- Housing Density: 35 dwelling units per acre

ALL DISTRICTS

Building Placement

Outdoor Space

Creeks & Landscape

Parking & Circulation

Height & Scale

Building Design

Amenities

Service & Utility

WEST END

DOWNTOWN RETAIL

PLAZA

EAST END

SECTION	East End District
ALL DISTRICTS	East End District Guidelines
Building Placement	<u>BUILDING PLACEMENT</u>
Outdoor Space	<u>OUTDOOR SPACE</u>
Creeks & Landscape	<u>CREEKS & LANDSCAPE</u>
Parking & Circulation	<u>PARKING & CIRCULATION</u>
Height & Scale	<u>HEIGHT & SCALE</u>
Building Design	
Amenities	
Service & Utility	
WEST END	
DOWNTOWN RETAIL	
PLAZA	
EAST END	

East End District Guidelines

BUILDING PLACEMENT

1. Maintain an informal arrangement of buildings through varied setbacks and spacing.

OUTDOOR SPACE

2. Consider locating outdoor space internal to the site to provide a visual or sound buffer from the street.

CREEKS & LANDSCAPE

3. Mitigate freeway impacts by incorporating trees and dense vegetation.
4. Increase landscaping between the development and the street to improve aesthetics and the pedestrian experience.

PARKING & CIRCULATION

5. Provide continuous pedestrian circulation through:
 - a. Closing walkway gaps,
 - b. Delineating a walking route with striping where a traditional walkway would limit access to a business, or
 - c. Providing meandering, informal walkways with recognizable separation of pedestrians and vehicles

HEIGHT & SCALE

6. Use increased setbacks and backdrops, such as topography, the freeway, and existing development, to mitigate building height.



Guidelines 1 and 4



Guideline 2



Guideline 2

Brown Avenue Character Area

Brown Avenue Character Area Vision:

Brown Avenue, as further described in the [Downtown Specific Plan \(DSP\)](#), is a mixed-use area with a small-scale residential character. This district is characterized by an eclectic mix of one and two-story buildings or clusters of buildings. The intent is to maintain the small-scale development, and encourage café style restaurants, boutique retail, small offices, and multi-family residential housing.

Brown Avenue Character Area Zoning Standards:

- Height: 35 ft.
- Stories: 2
- Housing Density: 35 dwelling units per acre

Brown Avenue Character Area Guidelines:

1. Maintain the appearance of buildings with residential character through small-scale development with entry porches, landscaped front yards, dormers, small windows, or pitched roofs.



Guideline 1



Guideline 1



SECTION

ALL DISTRICTS

Building Placement

Outdoor Space

Creeks & Landscape

Parking & Circulation

Height & Scale

Building Design

Amenities

Service & Utility

WEST END

DOWNTOWN RETAIL

PLAZA

EAST END

Definitions

1. **Amenities** are features that provide comfort, convenience, or pleasure, such as benches, lighting, public art, signage, receptacles, and water fountains. They are important features in the downtown in that they blend the public and private realm, enhance the vitality of an area, create visual interest, and tie the building to the greater context.
2. **Connected parking** is a parking management tool through which property owners provide access between their parking lots. This tool reduces the number of driveways, improves circulation on and off-site, and better utilizes existing parking by making the parking lots more accessible.
3. **Public realm** is a public, semi-public, or private space that is physically or visually accessible from public space. This is important in the downtown in that it provides a sense of openness by expanding sidewalks or opening up views of hills or creeks.
4. **Riparian areas** are comprised of the vegetative and wildlife areas adjacent to perennial and intermittent streams. Riparian areas are delineated by the existence of plant species normally found near freshwater.
5. **Semi-public space** is privately owned property that provides some physical or visual public access. This is often a transitional area between public and private spaces, and may have restricted access. The goal is to seamlessly blend the spaces and not to delineate property lines.
6. **Service and utility areas** are commodities or services provided by a public utility and include, but are not limited to: refuse/recycling enclosures, mechanical equipment, transformers, HVAC units, electrical and communication transformers/cabinets, wireless communications facilities, antennas, satellite dishes, backflow prevention/anti-siphon valves, pipes, meters, meter boxes, utility poles and wires, etc.
7. **Setback** is the horizontal separation required between lot lines and the nearest point of a building or structure.
8. **Shared parking** is a parking management tool through which adjacent or nearby property owners share their parking lots and reduce the number of parking spaces that each would provide on their individual properties. Typically the peak period of use is different for each businesses' use.
9. **Step-back** is when an upper floor is set back from the edge of the lower level to reduce its apparent mass and height.

Acknowledgements and Credits

Prepared by Downtown Design Guidelines Subcommittee

Tom Chastain, Planning Commissioner

Bob Cleaver, Design Review Commissioner

Andre Ptaszynski, Design Review Commissioner

Staff Liaisons

Anthony Arrivas, Planning Technician

Megan Canales, Planning Technician

Michael P. Cass, Associate Planner

Lindy Chan, Senior Planner

Greg Wolff, Senior Planner



CONTRA COSTA COUNTY LIBRARY