

All Traffic Data

(916) 771-8700
F (916) 786-2879

LAFAYETTE

File Name : 09-7331-022 OAK HILL-DEER HILL-F
Site Code : 00000000
Start Date : 09/03/2009
Page No : 1

Groups Printed- Unshifted

Start Time	OAK HILL RD. Southbound					DEER HILL RD. Westbound					OAK HILL RD. Northbound					DEER HILL RD. Eastbound					Exclu. Total	Inclu. Total	Int. Total
	Left	Thru	Right	Peds	App. Total	Left	Thru	Right	Peds	App. Total	Left	Thru	Right	Peds	App. Total	Left	Thru	Right	Peds	App. Total			
07:00	1	1	1	1	3	39	98	0	0	137	38	0	42	20	80	0	67	14	3	81	24	301	325
07:15	7	1	1	1	9	45	140	1	1	186	17	0	64	114	81	1	113	18	1	132	117	408	525
07:30	4	0	2	1	6	27	141	4	0	172	25	2	81	106	108	3	139	14	1	156	108	442	550
07:45	9	2	0	2	11	39	174	3	2	216	31	1	93	76	125	4	121	15	2	140	82	492	574
Total	21	4	4	5	29	150	553	8	3	711	111	3	280	316	394	8	440	61	7	509	331	1643	1974
08:00	5	0	4	0	9	38	229	0	0	267	33	1	77	96	111	1	112	16	1	129	97	516	613
08:15	3	1	4	3	8	46	224	4	0	274	29	2	77	60	108	2	122	21	1	145	64	535	599
08:30	3	3	0	1	6	52	169	2	0	223	26	6	76	39	108	4	100	22	3	126	43	463	506
08:45	5	1	3	2	9	53	175	10	1	238	27	0	99	3	126	1	81	16	2	98	8	471	479
Total	16	5	11	6	32	189	797	16	1	1002	115	9	329	198	453	8	415	75	7	498	212	1985	2197
*** BREAK ***																							
11:45	3	2	0	0	5	53	104	1	0	158	29	2	64	2	95	0	104	14	0	118	2	376	378
Total	3	2	0	0	5	53	104	1	0	158	29	2	64	2	95	0	104	14	0	118	2	376	378
12:00	2	1	0	0	3	33	108	2	0	143	19	2	81	1	102	1	101	17	0	119	1	367	368
12:15	4	1	0	0	5	50	110	2	0	162	25	2	76	0	103	0	87	23	0	110	0	380	380
12:30	3	1	0	1	4	36	103	3	0	142	21	1	84	3	106	0	102	12	1	114	5	366	371
12:45	1	1	1	0	3	50	107	1	0	158	20	2	79	2	101	3	101	11	0	115	2	377	379
Total	10	4	1	1	15	169	428	8	0	605	85	7	320	6	412	4	391	63	1	458	8	1490	1498
13:00	2	0	2	0	4	44	92	1	0	137	11	3	75	3	89	1	86	11	0	98	3	328	331
13:15	4	0	0	0	4	35	114	1	0	150	22	4	68	2	94	0	94	9	0	103	2	351	353
13:30	3	0	0	0	3	36	103	1	0	140	16	2	58	3	76	4	94	9	0	107	3	326	329
13:45	0	0	2	0	2	28	112	0	0	140	20	3	84	1	107	0	90	16	1	106	2	355	357
Total	9	0	4	0	13	143	421	3	0	567	69	12	285	9	366	5	364	45	1	414	10	1360	1370
14:00	4	2	2	0	8	37	109	2	0	148	23	2	82	3	107	0	88	14	2	102	5	365	370
14:15	2	1	0	0	3	38	123	3	0	164	24	2	75	7	101	2	97	12	0	111	7	379	386
14:30	3	0	3	0	6	35	115	1	0	151	24	2	78	4	104	2	121	22	0	145	4	406	410
14:45	1	2	1	0	4	41	122	3	0	166	26	1	85	5	112	5	115	22	0	142	5	424	429
Total	10	5	6	0	21	151	469	9	0	629	97	7	320	19	424	9	421	70	2	500	21	1574	1595
15:00	2	2	0	1	4	45	113	2	0	160	26	2	73	6	101	1	132	25	2	158	9	423	432
*** BREAK ***																							
Total	2	2	0	1	4	45	113	2	0	160	26	2	73	6	101	1	132	25	2	158	9	423	432
16:00	1	0	1	0	2	45	104	5	0	154	22	4	82	9	108	1	135	25	0	161	9	425	434
16:15	3	1	3	1	7	52	101	2	0	155	25	3	102	10	130	3	135	13	0	151	11	443	454
16:30	5	1	0	0	6	39	112	0	0	151	29	4	91	7	124	0	144	18	0	162	7	443	450
16:45	5	2	2	1	9	47	115	4	0	166	21	0	91	22	112	3	164	15	3	182	26	469	495
Total	14	4	6	2	24	183	432	11	0	626	97	11	366	48	474	7	578	71	3	656	53	1780	1833

All Traffic Data

(916) 771-8700
F (916) 786-2879

LAFAYETTE

File Name : 09-7331-022 OAK HILL-DEER HILL-F
Site Code : 00000000
Start Date : 09/03/2009
Page No : 2

Groups Printed- Unshifted

Start Time	OAK HILL RD. Southbound					DEER HILL RD. Westbound					OAK HILL RD. Northbound					DEER HILL RD. Eastbound					Exclu. Total	Inclu. Total	Int. Total
	Left	Thru	Right	Peds	App. Total	Left	Thru	Right	Peds	App. Total	Left	Thru	Right	Peds	App. Total	Left	Thru	Right	Peds	App. Total			
17:00	2	1	0	0	3	32	116	3	0	151	23	2	115	37	140	2	165	23	1	190	38	484	522
17:15	10	1	1	0	12	37	129	1	0	167	24	2	88	38	114	5	172	15	1	192	39	485	524
17:30	4	1	3	2	8	40	123	3	0	166	27	2	68	48	97	2	181	28	2	211	52	482	534
17:45	3	2	0	0	5	43	127	3	1	173	34	4	67	63	105	7	179	22	2	208	66	491	557
Total	19	5	4	2	28	152	495	10	1	657	108	10	338	186	456	16	697	88	6	801	195	1942	2137
Grand Total	104	31	36	17	171	1235	3812	68	5	5115	737	63	2375	790	3175	58	3542	512	29	4112	841	12573	13414
Apprch %	60.8	18.1	21.1			24.1	74.5	1.3			23.2	2	74.8			1.4	86.1	12.5					
Total %	0.8	0.2	0.3		1.4	9.8	30.3	0.5		40.7	5.9	0.5	18.9		25.3	0.5	28.2	4.1		32.7	6.3	93.7	

Start Time	OAK HILL RD. Southbound				App. Total	DEER HILL RD. Westbound				App. Total	OAK HILL RD. Northbound				App. Total	DEER HILL RD. Eastbound				Int. Total
	Left	Thru	Right	Peds		Left	Thru	Right	Peds		Left	Thru	Right	Peds		Left	Thru	Right	Peds	
Peak Hour Analysis From 07:00 to 08:45 - Peak 1 of 1																				
Peak Hour for Entire Intersection Begins at 07:45																				
07:45	9	2	0		11	39	174	3		216	31	1	93	125	4	121	15		140	492
08:00	5	0	4		9	38	229	0		267	33	1	77	111	1	112	16		129	516
08:15	3	1	4		8	46	224	4		274	29	2	77	108	2	122	21		145	535
08:30	3	3	0		6	52	169	2		223	26	6	76	108	4	100	22		126	463
Total Volume	20	6	8		34	175	796	9		980	119	10	323	452	11	455	74		540	2006
% App. Total	58.8	17.6	23.5			17.9	81.2	0.9			26.3	2.2	71.5		2	84.3	13.7			
PHF	.556	.500	.500		.773	.841	.869	.563		.894	.902	.417	.868	.904	.688	.932	.841		.931	.937

All Traffic Data

(916) 771-8700
F (916) 786-2879

LAFAYETTE

File Name : 09-7331-022 OAK HILL-DEER HILL-F
Site Code : 00000000
Start Date : 09/03/2009
Page No : 3

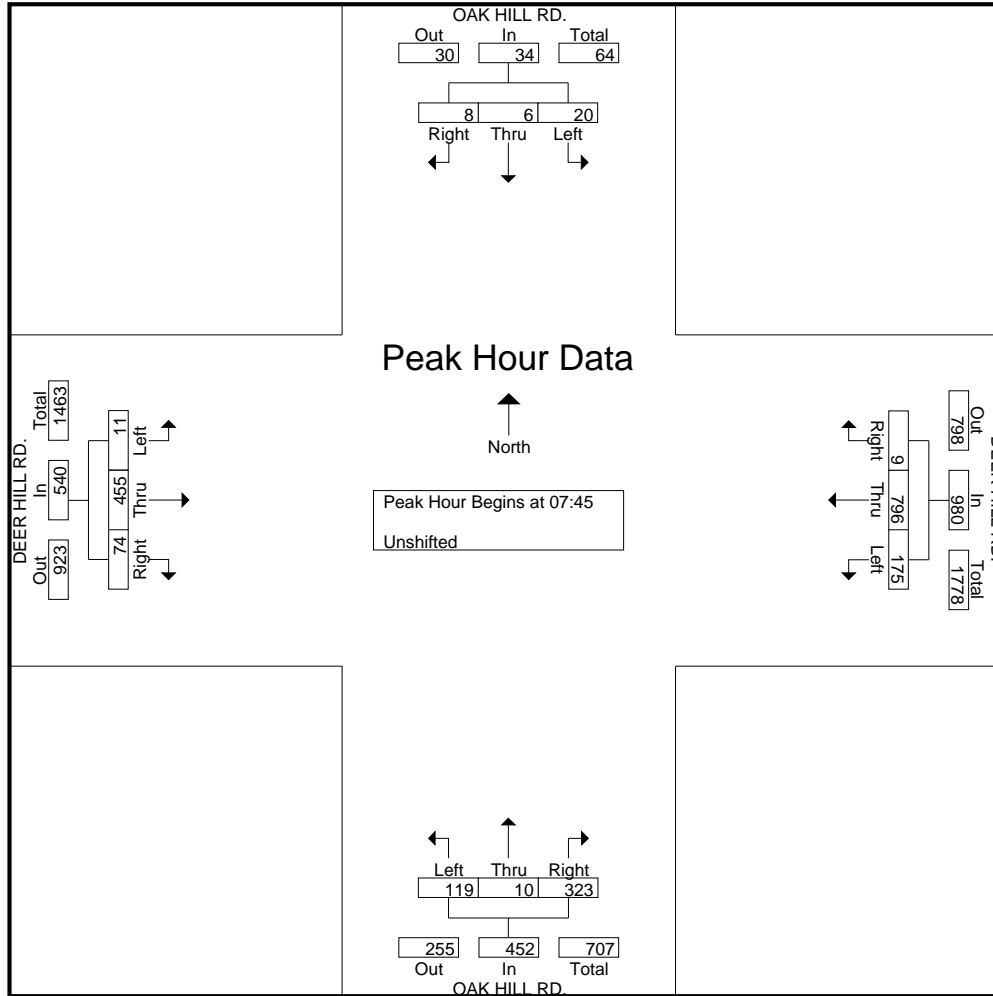

Peak Hour Analysis From 11:45 to 15:00 - Peak 1 of 1
Peak Hour for Entire Intersection Begins at 14:15

14:15	2	1	0	3	38	123	3	164	24	2	75	101	2	97	12	111	379
14:30	3	0	3	6	35	115	1	151	24	2	78	104	2	121	22	145	406
14:45	1	2	1	4	41	122	3	166	26	1	85	112	5	115	22	142	424
15:00	2	2	0	4	45	113	2	160	26	2	73	101	1	132	25	158	423
Total Volume	8	5	4	17	159	473	9	641	100	7	311	418	10	465	81	556	1632
% App. Total	47.1	29.4	23.5		24.8	73.8	1.4		23.9	1.7	74.4		1.8	83.6	14.6		
PHF	.667	.625	.333	.708	.883	.961	.750	.965	.962	.875	.915	.933	.500	.881	.810	.880	.962

All Traffic Data

(916) 771-8700
F (916) 786-2879

LAFAYETTE

File Name : 09-7331-022 OAK HILL-DEER HILL-F
Site Code : 00000000
Start Date : 09/03/2009
Page No : 4

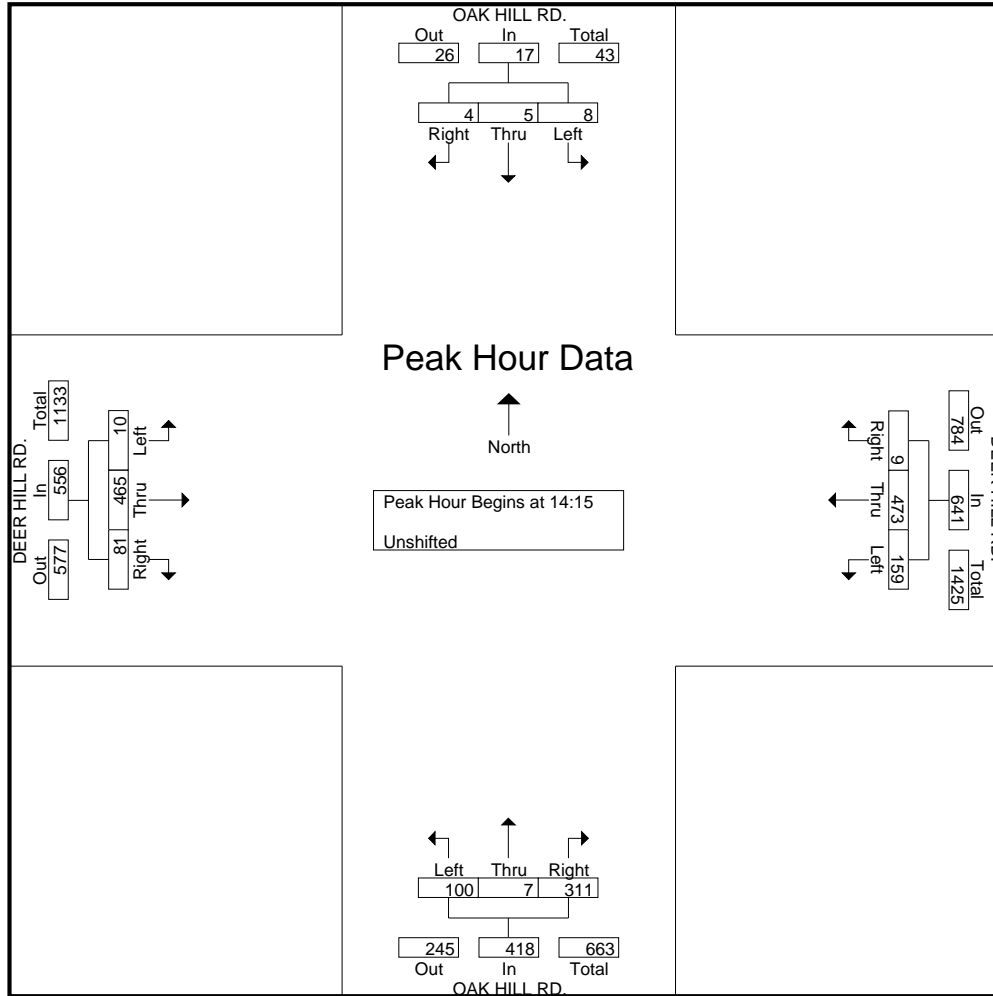

Peak Hour Analysis From 16:00 to 17:45 - Peak 1 of 1
Peak Hour for Entire Intersection Begins at 17:00

17:00	2	1	0	3	32	116	3	151	23	2	115	140	2	165	23	190	484
17:15	10	1	1	12	37	129	1	167	24	2	88	114	5	172	15	192	485
17:30	4	1	3	8	40	123	3	166	27	2	68	97	2	181	28	211	482
17:45	3	2	0	5	43	127	3	173	34	4	67	105	7	179	22	208	491
Total Volume	19	5	4	28	152	495	10	657	108	10	338	456	16	697	88	801	1942
% App. Total	67.9	17.9	14.3		23.1	75.3	1.5		23.7	2.2	74.1		2	87	11		
PHF	.475	.625	.333	.583	.884	.959	.833	.949	.794	.625	.735	.814	.571	.963	.786	.949	.989

All Traffic Data

(916) 771-8700
F (916) 786-2879

LAFAYETTE

File Name : 09-7331-022 OAK HILL-DEER HILL-F
Site Code : 00000000
Start Date : 09/03/2009
Page No : 5

