

# All Traffic Data

(916) 771-8700  
F (916) 786-2879

LAFAYETTE

File Name : 08-7280-017 MORAGA-MORAGA-F  
Site Code : 00000000  
Start Date : 05/15/2008  
Page No : 1

### Groups Printed- Unshifted

Start Time	MORAGA RD. Southbound					MORAGA BLVD. Westbound					MORAGA RD. Northbound					Eastbound					Exclu. Total	Inclu. Total	Int. Total
	Left	Thru	Right	Peds	App. Total	Left	Thru	Right	Peds	App. Total	Left	Thru	Right	Peds	App. Total	Left	Thru	Right	Peds	App. Total			
07:00 AM	3	132	0	0	135	4	0	4	0	8	0	189	8	1	197	0	0	0	0	0	1	340	341
07:15 AM	5	171	0	1	176	4	0	4	0	8	0	248	5	1	253	0	0	0	0	0	2	437	439
07:30 AM	4	179	0	0	183	6	0	5	3	11	0	257	8	5	265	0	0	0	0	0	8	459	467
07:45 AM	13	240	0	0	253	14	0	8	3	22	0	296	10	7	306	0	0	0	0	0	10	581	591
<b>Total</b>	<b>25</b>	<b>722</b>	<b>0</b>	<b>1</b>	<b>747</b>	<b>28</b>	<b>0</b>	<b>21</b>	<b>6</b>	<b>49</b>	<b>0</b>	<b>990</b>	<b>31</b>	<b>14</b>	<b>1021</b>	<b>0</b>	<b>0</b>	<b>0</b>	<b>0</b>	<b>0</b>	<b>21</b>	<b>1817</b>	<b>1838</b>
08:00 AM	7	180	0	0	187	10	0	14	3	24	0	291	16	3	307	0	0	0	0	0	6	518	524
08:15 AM	9	182	0	0	191	14	0	8	2	22	0	299	18	6	317	0	0	0	0	0	8	530	538
08:30 AM	11	186	0	0	197	9	0	11	10	20	0	307	19	7	326	0	0	0	0	0	17	543	560
08:45 AM	6	187	1	0	194	7	0	11	0	18	0	261	13	13	274	0	0	0	0	0	13	486	499
<b>Total</b>	<b>33</b>	<b>735</b>	<b>1</b>	<b>0</b>	<b>769</b>	<b>40</b>	<b>0</b>	<b>44</b>	<b>15</b>	<b>84</b>	<b>0</b>	<b>1158</b>	<b>66</b>	<b>29</b>	<b>1224</b>	<b>0</b>	<b>0</b>	<b>0</b>	<b>0</b>	<b>0</b>	<b>44</b>	<b>2077</b>	<b>2121</b>
*** BREAK ***																							
04:00 PM	10	206	0	1	216	9	0	14	0	23	0	239	23	2	262	0	0	0	0	0	3	501	504
04:15 PM	16	201	0	0	217	6	0	12	2	18	0	243	19	4	262	0	0	0	0	0	6	497	503
04:30 PM	8	232	0	0	240	14	0	12	0	26	0	232	17	5	249	0	0	0	0	0	5	515	520
04:45 PM	6	234	0	0	240	8	0	10	5	18	0	255	21	4	276	0	0	0	0	0	9	534	543
<b>Total</b>	<b>40</b>	<b>873</b>	<b>0</b>	<b>1</b>	<b>913</b>	<b>37</b>	<b>0</b>	<b>48</b>	<b>7</b>	<b>85</b>	<b>0</b>	<b>969</b>	<b>80</b>	<b>15</b>	<b>1049</b>	<b>0</b>	<b>0</b>	<b>0</b>	<b>0</b>	<b>0</b>	<b>23</b>	<b>2047</b>	<b>2070</b>
05:00 PM	9	225	1	0	235	9	0	14	2	23	0	240	29	1	269	0	0	0	0	0	3	527	530
05:15 PM	11	269	1	0	281	11	0	13	3	24	1	225	17	3	243	0	0	0	0	0	6	548	554
05:30 PM	9	262	0	0	271	10	1	7	15	18	0	239	10	13	249	0	0	0	0	0	28	538	566
05:45 PM	6	287	0	0	293	8	0	11	2	19	0	215	14	3	229	0	0	0	0	0	5	541	546
<b>Total</b>	<b>35</b>	<b>1043</b>	<b>2</b>	<b>0</b>	<b>1080</b>	<b>38</b>	<b>1</b>	<b>45</b>	<b>22</b>	<b>84</b>	<b>1</b>	<b>919</b>	<b>70</b>	<b>20</b>	<b>990</b>	<b>0</b>	<b>0</b>	<b>0</b>	<b>0</b>	<b>0</b>	<b>42</b>	<b>2154</b>	<b>2196</b>
<b>Grand Total</b>	<b>133</b>	<b>3373</b>	<b>3</b>	<b>2</b>	<b>3509</b>	<b>143</b>	<b>1</b>	<b>158</b>	<b>50</b>	<b>302</b>	<b>1</b>	<b>4036</b>	<b>247</b>	<b>78</b>	<b>4284</b>	<b>0</b>	<b>0</b>	<b>0</b>	<b>0</b>	<b>0</b>	<b>130</b>	<b>8095</b>	<b>8225</b>
<b>Apprch %</b>	<b>3.8</b>	<b>96.1</b>	<b>0.1</b>			<b>47.4</b>	<b>0.3</b>	<b>52.3</b>			<b>0</b>	<b>94.2</b>	<b>5.8</b>			<b>0</b>	<b>0</b>	<b>0</b>					
<b>Total %</b>	<b>1.6</b>	<b>41.7</b>	<b>0</b>		<b>43.3</b>	<b>1.8</b>	<b>0</b>	<b>2</b>		<b>3.7</b>	<b>0</b>	<b>49.9</b>	<b>3.1</b>		<b>52.9</b>	<b>0</b>	<b>0</b>	<b>0</b>		<b>0</b>	<b>1.6</b>	<b>98.4</b>	

Start Time	MORAGA RD. Southbound				MORAGA BLVD. Westbound				MORAGA RD. Northbound				Eastbound				Int. Total
	Left	Thru	Right	App. Total	Left	Thru	Right	App. Total	Left	Thru	Right	App. Total	Left	Thru	Right	App. Total	
Peak Hour Analysis From 07:00 AM to 08:45 AM - Peak 1 of 1																	
Peak Hour for Entire Intersection Begins at 07:45 AM																	
07:45 AM	<b>13</b>	<b>240</b>	<b>0</b>	<b>253</b>	<b>14</b>	<b>0</b>	<b>8</b>	<b>22</b>	<b>0</b>	<b>296</b>	<b>10</b>	<b>306</b>	<b>0</b>	<b>0</b>	<b>0</b>	<b>0</b>	<b>581</b>
08:00 AM	7	180	0	187	10	0	14	24	0	291	16	307	0	0	0	0	518
08:15 AM	9	182	0	191	14	0	8	22	0	299	18	317	0	0	0	0	530
08:30 AM	11	186	0	197	9	0	11	20	0	<b>307</b>	<b>19</b>	<b>326</b>	0	0	0	0	543
<b>Total Volume</b>	<b>40</b>	<b>788</b>	<b>0</b>	<b>828</b>	<b>47</b>	<b>0</b>	<b>41</b>	<b>88</b>	<b>0</b>	<b>1193</b>	<b>63</b>	<b>1256</b>	<b>0</b>	<b>0</b>	<b>0</b>	<b>0</b>	<b>2172</b>
<b>% App. Total</b>	<b>4.8</b>	<b>95.2</b>	<b>0</b>		<b>53.4</b>	<b>0</b>	<b>46.6</b>		<b>0</b>	<b>95</b>	<b>5</b>		<b>0</b>	<b>0</b>	<b>0</b>		

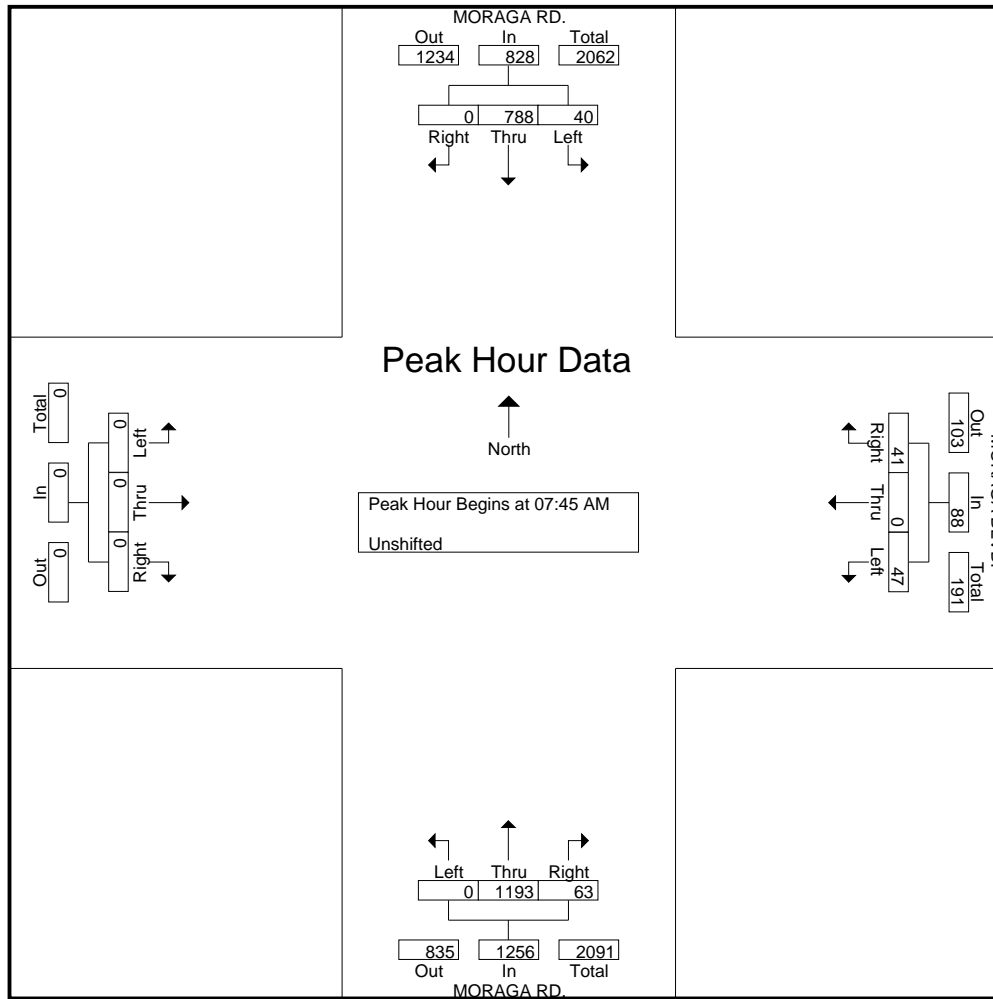

Peak Hour Analysis From 04:00 PM to 05:45 PM - Peak 1 of 1

Peak Hour for Entire Intersection Begins at 05:00 PM

05:00 PM	9	225	1	235	9	0	14	23	0	240	29	269	0	0	0	0	527
05:15 PM	11	269	1	281	11	0	13	24	1	225	17	243	0	0	0	0	548
05:30 PM	9	262	0	271	10	1	7	18	0	239	10	249	0	0	0	0	538
05:45 PM	6	287	0	293	8	0	11	19	0	215	14	229	0	0	0	0	541
Total Volume	35	1043	2	1080	38	1	45	84	1	919	70	990	0	0	0	0	2154
% App. Total	3.2	96.6	0.2		45.2	1.2	53.6		0.1	92.8	7.1		0	0	0		
PHF	.795	.909	.500	.922	.864	.250	.804	.875	.250	.957	.603	.920	.000	.000	.000	.000	.983

# All Traffic Data

(916) 771-8700  
F (916) 786-2879

LAFAYETTE

File Name : 08-7280-017 MORAGA-MORAGA-F  
Site Code : 00000000  
Start Date : 05/15/2008  
Page No : 3

