

# All Traffic Data

(916) 771-8700  
F (916) 786-2879

LAFAYETTE

File Name : 09-7331-015 PLEASANT HILL-OLD TUNNEL-F  
Site Code : 00000000  
Start Date : 09/01/2009  
Page No : 1

## Groups Printed- Unshifted

Start Time	PLEASANT HILL RD. Southbound					OLD TUNNEL RD. Westbound					PLEASANT HILL RD. Northbound					EB CA 24 OFF RAMP Eastbound					Exclu. Total	Inclu. Total	Int. Total
	Left	Thru	Right	Peds	App. Total	Left	Thru	Right	Peds	App. Total	Left	Thru	Right	Peds	App. Total	Left	Thru	Right	Peds	App. Total			
07:00	9	59	0	0	68	1	0	15	0	16	0	141	1	0	142	7	2	25	3	34	3	260	263
07:15	10	90	0	0	100	3	0	21	3	24	0	174	4	0	178	6	4	31	1	41	4	343	347
07:30	9	108	0	0	117	4	0	28	3	32	0	253	7	0	260	5	4	28	1	37	4	446	450
07:45	14	105	0	0	119	15	0	49	0	64	0	291	3	0	294	10	4	24	5	38	5	515	520
Total	42	362	0	0	404	23	0	113	6	136	0	859	15	0	874	28	14	108	10	150	16	1564	1580
08:00	16	122	0	0	138	8	0	34	0	42	0	261	1	0	262	6	4	25	2	35	2	477	479
08:15	11	119	0	0	130	1	0	40	0	41	0	221	9	0	230	13	3	38	1	54	1	455	456
08:30	20	116	0	0	136	1	0	24	0	25	0	235	5	0	240	15	4	37	0	56	0	457	457
08:45	17	117	0	0	134	1	0	33	3	34	0	181	5	1	186	13	5	41	1	59	5	413	418
Total	64	474	0	0	538	11	0	131	3	142	0	898	20	1	918	47	16	141	4	204	8	1802	1810
*** BREAK ***																							
11:45	21	111	0	0	132	2	0	18	2	20	0	169	8	3	177	12	5	34	1	51	6	380	386
Total	21	111	0	0	132	2	0	18	2	20	0	169	8	3	177	12	5	34	1	51	6	380	386
12:00	24	100	0	0	124	5	0	29	0	34	0	158	1	0	159	9	9	45	0	63	0	380	380
12:15	15	98	0	0	113	2	0	31	0	33	0	152	8	0	160	7	6	36	0	49	0	355	355
12:30	26	114	0	0	140	2	0	29	0	31	0	151	4	0	155	13	6	29	0	48	0	374	374
12:45	16	112	0	0	128	3	0	31	2	34	0	159	0	0	159	15	7	47	0	69	2	390	392
Total	81	424	0	0	505	12	0	120	2	132	0	620	13	0	633	44	28	157	0	229	2	1499	1501
13:00	20	113	0	0	133	2	0	16	0	18	0	152	3	0	155	14	9	31	0	54	0	360	360
13:15	20	102	0	0	122	1	0	24	0	25	0	171	1	0	172	12	4	39	0	55	0	374	374
13:30	14	127	0	0	141	1	0	23	0	24	0	140	4	1	144	7	11	46	1	64	2	373	375
13:45	27	104	0	0	131	2	0	22	0	24	0	166	3	0	169	8	5	51	0	64	0	388	388
Total	81	446	0	0	527	6	0	85	0	91	0	629	11	1	640	41	29	167	1	237	2	1495	1497
14:00	19	120	0	0	139	4	0	35	3	39	0	145	4	2	149	7	7	37	1	51	6	378	384
14:15	24	144	0	0	168	8	0	31	5	39	0	162	3	0	165	15	6	39	1	60	6	432	438
14:30	16	137	0	0	153	4	0	19	0	23	0	180	2	0	182	9	7	34	0	50	0	408	408
14:45	21	132	0	0	153	4	0	20	0	24	0	213	9	0	222	15	5	53	0	73	0	472	472
Total	80	533	0	0	613	20	0	105	8	125	0	700	18	2	718	46	25	163	2	234	12	1690	1702
15:00	31	117	0	0	148	6	0	29	0	35	0	210	5	0	215	13	7	38	3	58	3	456	459
*** BREAK ***																							
Total	31	117	0	0	148	6	0	29	0	35	0	210	5	0	215	13	7	38	3	58	3	456	459
16:00	15	120	0	0	135	4	0	40	0	44	0	189	3	0	192	15	13	42	0	70	0	441	441
16:15	16	125	0	0	141	4	0	18	0	22	0	198	4	1	202	16	11	44	1	71	2	436	438
16:30	31	123	0	0	154	5	0	27	0	32	0	219	2	0	221	13	14	43	0	70	0	477	477
16:45	31	134	0	0	165	3	0	22	4	25	0	175	3	0	178	16	10	51	0	77	4	445	449
Total	93	502	0	0	595	16	0	107	4	123	0	781	12	1	793	60	48	180	1	288	6	1799	1805

# All Traffic Data

(916) 771-8700  
F (916) 786-2879

LAFAYETTE

File Name : 09-7331-015 PLEASANT HILL-OLD TUNNEL-F  
Site Code : 00000000  
Start Date : 09/01/2009  
Page No : 2

### Groups Printed- Unshifted

Start Time	PLEASANT HILL RD. Southbound					OLD TUNNEL RD. Westbound					PLEASANT HILL RD. Northbound					EB CA 24 OFF RAMP Eastbound					Exclu. Total	Inclu. Total	Int. Total
	Left	Thru	Right	Peds	App. Total	Left	Thru	Right	Peds	App. Total	Left	Thru	Right	Peds	App. Total	Left	Thru	Right	Peds	App. Total			
17:00	26	150	0	0	176	10	0	27	2	37	0	191	5	0	196	19	17	53	0	89	2	498	500
17:15	25	151	0	0	176	3	0	28	0	31	0	208	8	0	216	6	10	62	1	78	1	501	502
17:30	26	188	0	0	214	8	0	29	2	37	0	186	1	2	187	14	14	78	1	106	5	544	549
17:45	21	165	0	0	186	6	0	23	2	29	0	150	5	0	155	14	15	70	0	99	2	469	471
<b>Total</b>	<b>98</b>	<b>654</b>	<b>0</b>	<b>0</b>	<b>752</b>	<b>27</b>	<b>0</b>	<b>107</b>	<b>6</b>	<b>134</b>	<b>0</b>	<b>735</b>	<b>19</b>	<b>2</b>	<b>754</b>	<b>53</b>	<b>56</b>	<b>263</b>	<b>2</b>	<b>372</b>	<b>10</b>	<b>2012</b>	<b>2022</b>
<b>Grand Total</b>	<b>591</b>	<b>3623</b>	<b>0</b>	<b>0</b>	<b>4214</b>	<b>123</b>	<b>0</b>	<b>815</b>	<b>31</b>	<b>938</b>	<b>0</b>	<b>5601</b>	<b>121</b>	<b>10</b>	<b>5722</b>	<b>344</b>	<b>228</b>	<b>1251</b>	<b>24</b>	<b>1823</b>	<b>65</b>	<b>12697</b>	<b>12762</b>
Apprch %	14	86	0			13.1	0	86.9			0	97.9	2.1			18.9	12.5	68.6					
Total %	4.7	28.5	0		33.2	1	0	6.4		7.4	0	44.1	1		45.1	2.7	1.8	9.9		14.4	0.5	99.5	

Start Time	PLEASANT HILL RD. Southbound				OLD TUNNEL RD. Westbound				PLEASANT HILL RD. Northbound				EB CA 24 OFF RAMP Eastbound				Int. Total
	Left	Thru	Right	App. Total	Left	Thru	Right	App. Total	Left	Thru	Right	App. Total	Left	Thru	Right	App. Total	
Peak Hour Analysis From 07:00 to 08:45 - Peak 1 of 1																	
Peak Hour for Entire Intersection Begins at 07:45																	
07:45	14	105	0	119	<b>15</b>	0	<b>49</b>	<b>64</b>	0	<b>291</b>	3	<b>294</b>	10	<b>4</b>	24	38	<b>515</b>
08:00	16	<b>122</b>	0	<b>138</b>	8	0	34	42	0	261	1	262	6	4	25	35	477
08:15	11	119	0	130	1	0	40	41	0	221	<b>9</b>	230	13	3	<b>38</b>	54	455
08:30	<b>20</b>	116	0	136	1	0	24	25	0	235	5	240	<b>15</b>	4	37	<b>56</b>	457
Total Volume	61	462	0	523	25	0	147	172	0	1008	18	1026	44	15	124	183	1904
% App. Total	11.7	88.3	0		14.5	0	85.5		0	98.2	1.8		24	8.2	67.8		
PHF	.763	.947	.000	.947	.417	.000	.750	.672	.000	.866	.500	.872	.733	.938	.816	.817	.924

# All Traffic Data

(916) 771-8700  
F (916) 786-2879

LAFAYETTE

File Name : 09-7331-015 PLEASANT HILL-OLD TUNNEL-F  
Site Code : 00000000  
Start Date : 09/01/2009  
Page No : 3

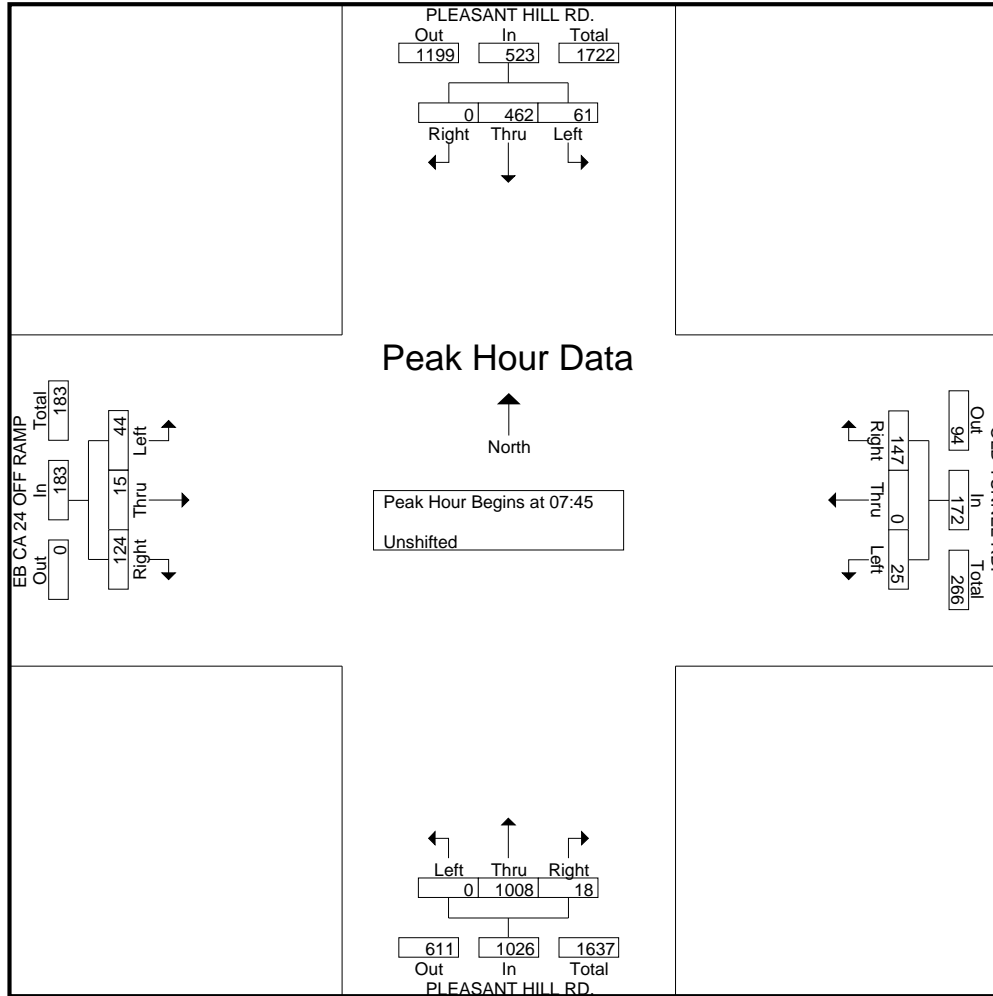

Peak Hour Analysis From 11:45 to 15:00 - Peak 1 of 1  
Peak Hour for Entire Intersection Begins at 14:15

14:15	24	<b>144</b>	0	<b>168</b>	<b>8</b>	0	<b>31</b>	<b>39</b>	0	162	3	165	<b>15</b>	6	39	60	432
14:30	16	137	0	153	4	0	19	23	0	180	2	182	9	7	34	50	408
14:45	21	132	0	153	4	0	20	24	0	<b>213</b>	<b>9</b>	<b>222</b>	15	5	<b>53</b>	<b>73</b>	<b>472</b>
15:00	<b>31</b>	117	0	148	6	0	29	35	0	210	5	215	13	7	38	58	456
Total Volume	92	530	0	622	22	0	99	121	0	765	19	784	52	25	164	241	1768
% App. Total	14.8	85.2	0		18.2	0	81.8		0	97.6	2.4		21.6	10.4	68		
PHF	.742	.920	.000	.926	.688	.000	.798	.776	.000	.898	.528	.883	.867	.893	.774	.825	.936

# All Traffic Data

(916) 771-8700  
F (916) 786-2879

LAFAYETTE

File Name : 09-7331-015 PLEASANT HILL-OLD TUNNEL-F  
Site Code : 00000000  
Start Date : 09/01/2009  
Page No : 4

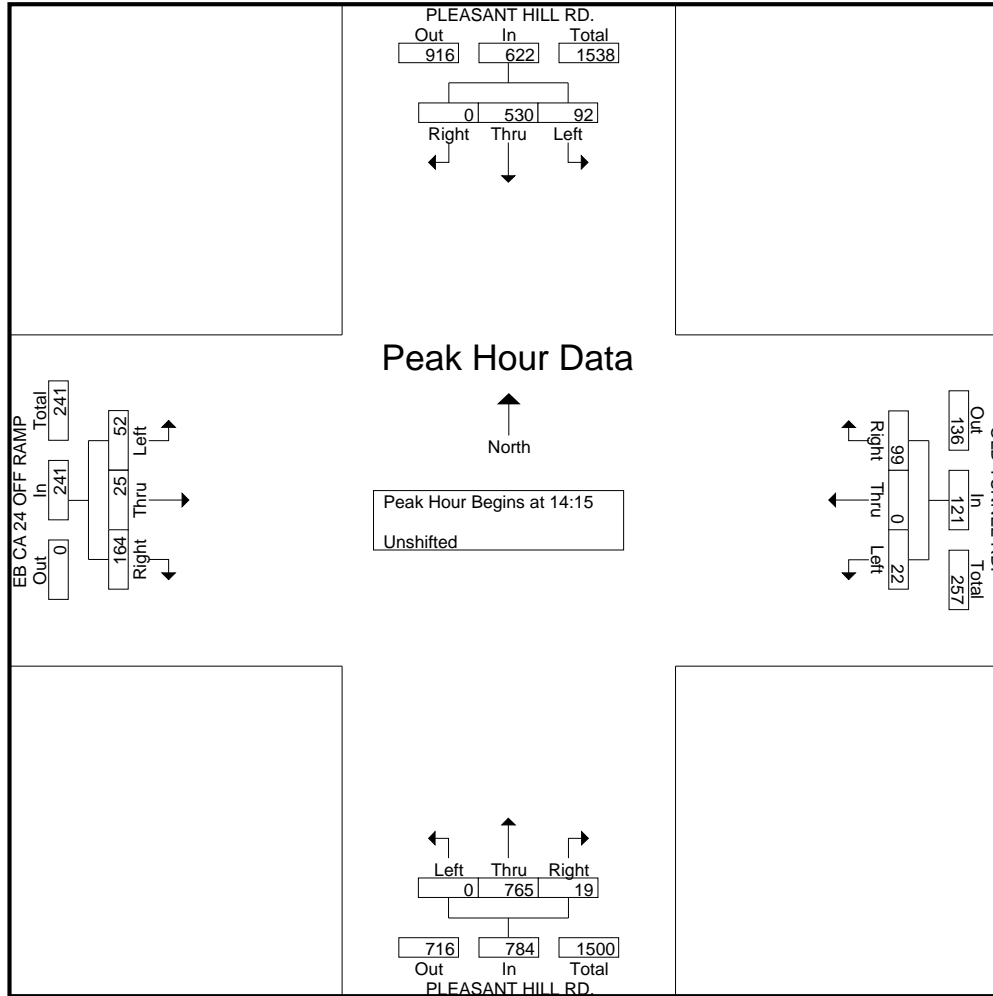

Peak Hour Analysis From 16:00 to 17:45 - Peak 1 of 1  
Peak Hour for Entire Intersection Begins at 17:00

17:00	26	150	0	176	10	0	27	37	0	191	5	196	19	17	53	89	498
17:15	25	151	0	176	3	0	28	31	0	208	8	216	6	10	62	78	501
17:30	26	188	0	214	8	0	29	37	0	186	1	187	14	14	78	106	544
17:45	21	165	0	186	6	0	23	29	0	150	5	155	14	15	70	99	469
Total Volume	98	654	0	752	27	0	107	134	0	735	19	754	53	56	263	372	2012
% App. Total	13	87	0	20.1	0	0	79.9	0	0	97.5	2.5	14.2	15.1	70.7			
PHF	.942	.870	.000	.879	.675	.000	.922	.905	.000	.883	.594	.873	.697	.824	.843	.877	.925

# All Traffic Data

(916) 771-8700  
F (916) 786-2879

LAFAYETTE

File Name : 09-7331-015 PLEASANT HILL-OLD TUNNEL-F  
Site Code : 00000000  
Start Date : 09/01/2009  
Page No : 5

